



Chipsmall Limited consists of a professional team with an average of over 10 year of expertise in the distribution of electronic components. Based in Hongkong, we have already established firm and mutual-benefit business relationships with customers from,Europe,America and south Asia,supplying obsolete and hard-to-find components to meet their specific needs.

With the principle of “Quality Parts,Customers Priority,Honest Operation,and Considerate Service”,our business mainly focus on the distribution of electronic components. Line cards we deal with include Microchip,ALPS,ROHM,Xilinx,Pulse,ON,Everlight and Freescale. Main products comprise IC,Modules,Potentiometer,IC Socket,Relay,Connector.Our parts cover such applications as commercial,industrial, and automotives areas.

We are looking forward to setting up business relationship with you and hope to provide you with the best service and solution. Let us make a better world for our industry!



## Contact us

Tel: +86-755-8981 8866 Fax: +86-755-8427 6832

Email & Skype: info@chipsmall.com Web: www.chipsmall.com

Address: A1208, Overseas Decoration Building, #122 Zhenhua RD., Futian, Shenzhen, China





## 3.3V Phase-Lock Loop Clock Driver

### General Description

The **ICS2510C** is a high performance, low skew, low jitter clock driver. It uses a phase lock loop (PLL) technology to align, in both phase and frequency, the CLKIN signal with the CLKOUT signal. It is specifically designed for use with synchronous SDRAMs. The **ICS2510C** operates at 3.3V VCC and drives up to ten clock loads.

One bank of ten outputs provide low-skew, low-jitter copies of CLKIN. Output signal duty cycles are adjusted to 50 percent, independent of the duty cycle at CLKIN. Outputs can be enabled or disabled via control (OE) inputs. When the OE inputs are high, the outputs align in phase and frequency with CLKIN; when the OE inputs are low, the outputs are disabled to the logic low state.

The **ICS2510C** does not require external RC filter components. The loop filter for the PLL is included on-chip, minimizing component count, board space, and cost. The test mode shuts off the PLL and connects the input directly to the output buffer. This test mode, the **ICS2510C** can be use as low skew fanout clock buffer device. The **ICS2510C** comes in 24 pin 173mil Thin Shrink Small-Outline package (TSSOP) package.

### Features

- Meets or exceeds PC133 registered DIMM specification 1.1
- Spread Spectrum Clock Compatible
- Distributes one clock input to one bank of ten outputs
- Operating frequency 25MHz to 175MHz
- External feedback input (FBIN) terminal is used to synchronize the outputs to the clock input
- No external RC network required
- Operates at 3.3V Vcc
- Plastic 24-pin 173mil TSSOP package

### Block Diagram

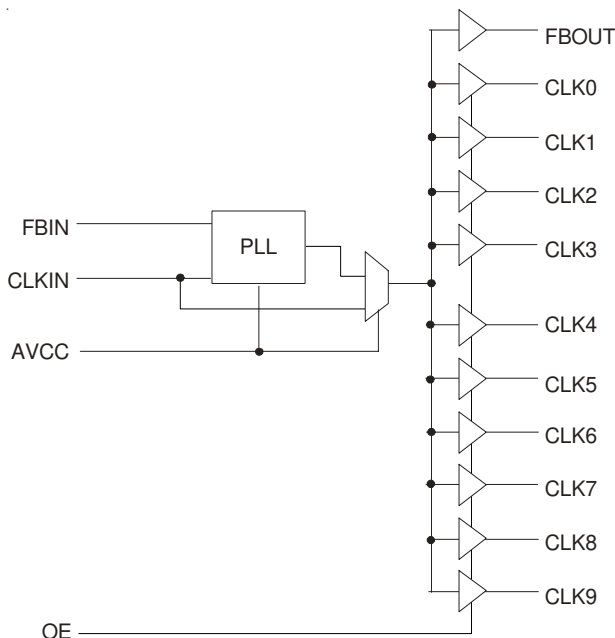

### Pin Configuration

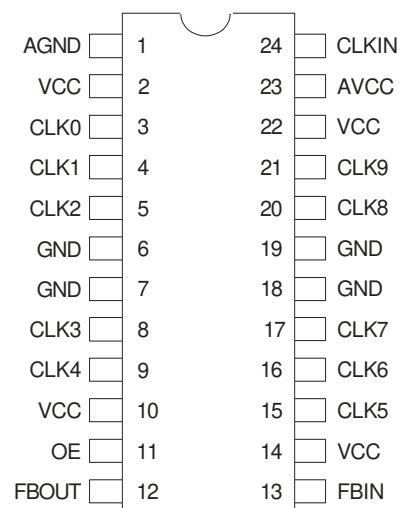

**24 Pin TSSOP**  
4.40 mm. Body, 0.65 mm. pitch



## Pin Descriptions

PIN NUMBER	PIN NAME	TYPE	DESCRIPTION
1	AGND	PWR	Analog Ground
2, 10, 14	VCC	PWR	Power Supply (3.3V)
3	CLK0	OUT	Buffered clock output.
4	CLK1	OUT	Buffered clock output.
5	CLK2	OUT	Buffered clock output.
6, 7, 18, 19	GND	PWR	Ground
8	CLK3	OUT	Buffered clock output.
9	CLK4	OUT	Buffered clock output.
11	OE <sup>1</sup>	IN	Output enable (has internal pull_up). When high, normal operation. When low, clock outputs are disabled to a logic low state.
12	FBOUT	OUT	Feedback output
13	FBIN	IN	Feedback input
15	CLK5	OUT	Buffered clock output.
16	CLK6	OUT	Buffered clock output.
17	CLK7	OUT	Buffered clock output.
20	CLK8	OUT	Buffered clock output.
21	CLK9	OUT	Buffered clock output.
22	VCC	PWR	Power Supply (3.3V) digital supply.
23	AVCC	IN	Analog power supply (3.3V). When input is ground PLL is off and bypassed.
24	CLKIN	IN	Clock input

Note:

1. Weak pull-ups on these inputs

## Functionality

INPUTS		OUTPUTS			PLL
OE	AVCC	CLK (9:0)	FBOUT	Source	Shutdown
0	3.33	0	Driven	PLL	N
1	3.33	Driven	Driven	PLL	N
Buffer Mode					
0	0	0	Driven	CLKIN	Y
1	0	Driven	Driven	CLKIN	Y

Test mode:

When AVCC is 0, shuts off the PLL and connects the input directly to the output buffers



### Absolute Maximum Ratings

Supply Voltage (AVCC) . . . . .	AVCC < (V <sub>CC</sub> + 0.7V)
Supply Voltage (VCC) . . . . .	4.3 V
Logic Inputs . . . . .	GND –0.5 V to V <sub>CC</sub> +0.5 V
Ambient Operating Temperature . . . . .	0°C to +70°C
Storage Temperature . . . . .	–65°C to +150°C

Stresses above those listed under *Absolute Maximum Ratings* may cause permanent damage to the device. These ratings are stress specifications only and functional operation of the device at these or any other conditions above those listed in the operational sections of the specifications is not implied. Exposure to absolute maximum rating conditions for extended periods may affect product reliability.

### Electrical Characteristics - OUTPUT

T<sub>A</sub> = 0 - 70°C; V<sub>DD</sub> = V<sub>DDL</sub> = 3.3 V +/-10%; C<sub>L</sub> = 20 - 30 pF; R<sub>L</sub> = 470 Ohms (unless otherwise stated)

PARAMETER	SYMBOL	CONDITIONS	MIN	TYP	MAX	UNITS
Output Impedance	R <sub>DSP</sub>	V <sub>O</sub> = V <sub>DD</sub> *(0.5)		36		Ω
Output Impedance	R <sub>D<sub>SN</sub></sub>	V <sub>O</sub> = V <sub>DD</sub> *(0.5)		32		Ω
Output High Voltage	V <sub>OH</sub>	I <sub>OH</sub> = -8 mA	2.4	2.9		V
Output Low Voltage	V <sub>OL</sub>	I <sub>OL</sub> = 8 mA		0.25	0.4	V
Output High Current	I <sub>OH</sub>	V <sub>OH</sub> = 2.4 V		-26	-13.6	mA
		V <sub>OH</sub> = 2.0 V		-37	-22	
Output Low Current	I <sub>OL</sub>	V <sub>OL</sub> = 0.8 V	19	25		mA
		V <sub>OL</sub> = 0.55 V	13	17		
Rise Time <sup>1</sup>	T <sub>r</sub>	V <sub>OL</sub> = 0.8 V, V <sub>OH</sub> = 2.0 V	0.5	1.4	2.1	ns
Fall Time <sup>1</sup>	T <sub>f</sub>	V <sub>OH</sub> = 2.0 V, V <sub>OL</sub> = 0.8 V	0.5	1.5	2.7	ns
Duty Cycle <sup>1</sup>	D <sub>t</sub>	V <sub>T</sub> = 1.5 V; C <sub>L</sub> = 30 pF	45	50	55	%
Cycle to Cycle jitter <sup>1</sup>	T <sub>cyc-cyc</sub>	at 66-100 MHz ; loaded outputs		52	100	ps
		at 133 MHz ; loaded outputs		39	75	
Absolute Jitter <sup>1</sup>	T <sub>jabs</sub>	10000 cycles; C <sub>L</sub> = 30 pF		57		ps
Skew <sup>1</sup>	T <sub>sk</sub>	V <sub>T</sub> = 1.5 V (Window) Output to Output		80	150	ps
Phase error <sup>1</sup>	T <sub>pe</sub>	V <sub>T</sub> = V <sub>dd</sub> /2; CLKIN-FBIN	-150	40	150	ps
Phase error Jitter <sup>1</sup>	T <sub>pe</sub> <sup>3</sup>	V <sub>T</sub> = V <sub>dd</sub> /2; CLKIN-FBIN; Delay Jitter	-50	35	50	ps
Delay Input-Output <sup>1</sup>	D <sub>R1</sub>	V <sub>T</sub> = 1.5 V; PLL_EN = 0		3.3	3.7	ns

<sup>1</sup> Guaranteed by design, not 100% tested in production.



## Electrical Characteristics - Input & Supply

$T_A = 0 - 70^\circ\text{C}$ ; Supply Voltage  $V_{DD} = 3.3 \text{ V} \pm 10\%$  (unless otherwise stated)

PARAMETER	SYMBOL	CONDITIONS	MIN	TYP	MAX	UNITS
Input High Voltage	$V_{IH}$		2		$V_{DD} + 0.3$	V
Input Low Voltage	$V_{IL}$		$V_{SS} - 0.3$		0.8	V
Input High Current	$I_{IH}$	$V_{IN} = V_{DD}$		0.1	100	$\mu\text{A}$
Input Low Current	$I_{IL}$	$V_{IN} = 0 \text{ V}$ ;		19	50	$\mu\text{A}$
Operating current	$I_{DD1}$	$C_L = 0 \text{ pF}$ ; $F_{IN} @ 66\text{M}$		140	170	mA
Input Capacitance	$C_{IN}^1$	Logic Inputs		4		pF
Output Capacitance	$C_O^1$	Logic Outputs		8		pF

<sup>1</sup>Guaranteed by design, not 100% tested in production.

## Timing requirements over recommended ranges of supply voltage and operating free-air temperature

Symbol	Parameter	Test Conditions	Min.	Max.	Unit
Fclk	Input clock frequency		25	175	MHz
	Input clock frequency duty cycle		40	60	%
	Stabilization time	After power up		1	ms

Note: Time required for the PLL circuit to obtain phase lock of its feedback signal to its In order for phase lock to be obtained, a fixed-frequency, fixed-phase reference signal Until phase lock is obtained, the specifications for parameters given in the switching



**PARAMETER MEASUREMENT INFORMATION**

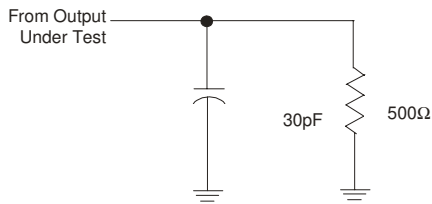

**Figure 1. Load Circuit for Outputs**

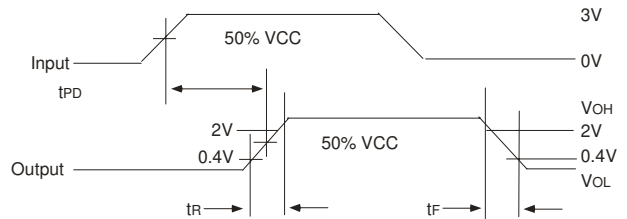

**Figure 2. Voltage Waveforms Propagation Delay Times**

Notes:

1.  $C_L$  includes probe and jig capacitance.
2. All input pulses are supplied by generators having the following characteristics:  $PRR \leq 133$  MHz,  $Z_O = 50\Omega$ ,  $T_r \leq 1.2$  ns,  $T_f \leq 1.2$  ns.
3. The outputs are measured one at a time with one transition per measurement.

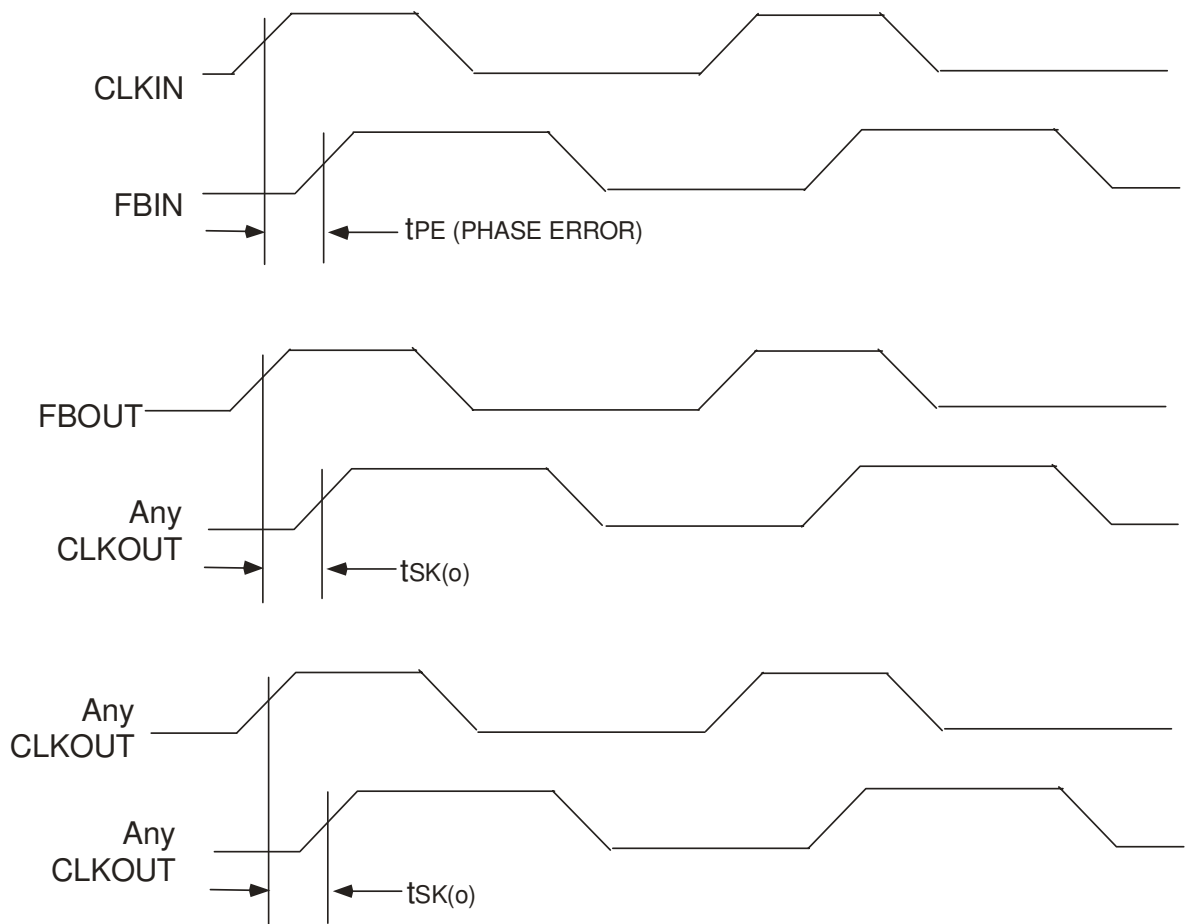

**Figure 3. Phase Error and Skew Calculations**



**General Layout Precautions:**

An ICS2509C is used as an example. It is similar to the ICS2510C. The same rules and methods apply.

- 1) Use copper flooded ground on the top signal layer under the clock buffer. The area under U1 in figure 1 on the right is an example. Every ground pin goes to a ground via. The vias are not visible in figure 1.
- 2) Use power vias for power and ground. Vias 20 mil or larger in diameter have lower high frequency impedance. Vias for signals may be minimum drill size.
- 3) Make all power and ground traces are as wide as the via pad for lower inductance.
- 4) VAA for pin 23 has a low pass RC filter to decouple the digital and analog supplies. C9-12 may be replaced with a single low ESR (0.8 ohm or less) device with the same total capacitance. R2 may be replaced with a ferrite bead. The bead should have a DC resistance of at least 0.5 ohms. 1 ohm is better. It should have an impedance of at least 300 ohms at 100MHz. 600 ohms at 100MHz is better.
- 5) Notice that ground vias are never shared.
- 6) All VCC pins have a decoupling capacitor. Power is always routed from the plane connection via to the capacitor pad to the VCC pin on the clock buffer.
- 7) Component R1 is located at the clock source.
- 8) Component C1, if used, has the effect of adding delay.
- 9) Component C7, if used, has the effect of subtracting delay. Delaying the FBIn clock will cause the output clocks to be earlier. A more effective method is to use the propagation time of a trace between FBOut and FBIn.

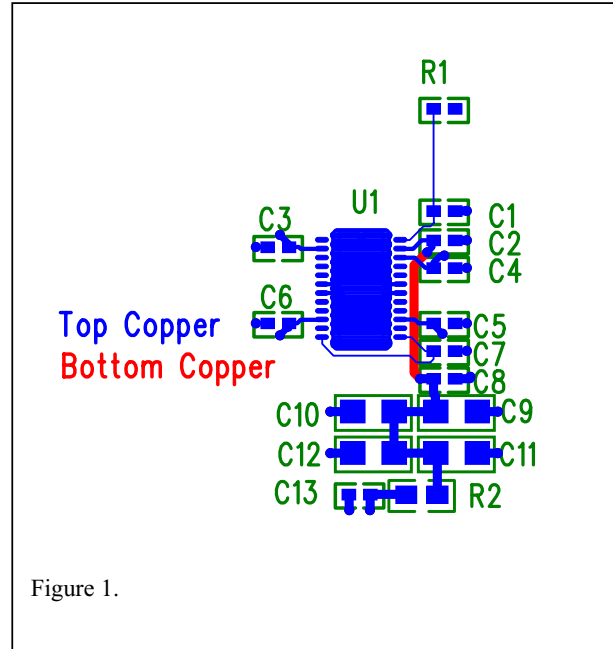
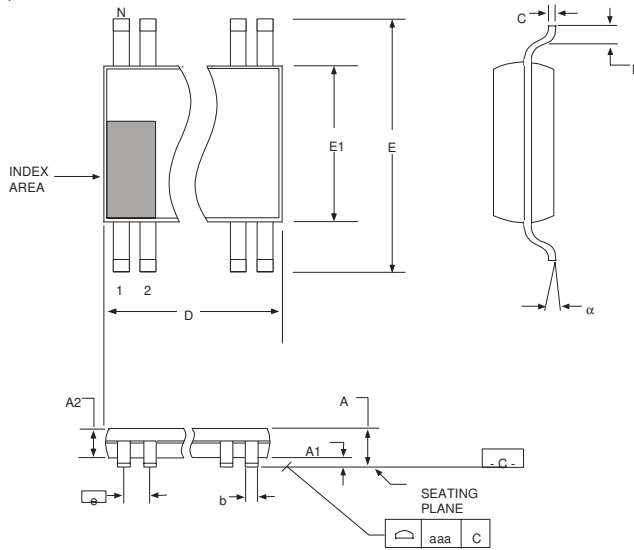

Figure 1.

**Component Values:**

C1, C7= As necessary for delay adjust  
 C [6 : 2] = .01uF  
 C8, C13=0.1uF  
 C [12 : 9]=4.7uF  
 R1=10 ohm. Locate at driver  
 R2=10 ohm.



SYMBOL	In Millimeters COMMON DIMENSIONS		In Inches COMMON DIMENSIONS	
	MIN	MAX	MIN	MAX
A	--	1.20	--	.047
A1	0.05	0.15	.002	.006
A2	0.80	1.05	.032	.041
b	0.19	0.30	.007	.012
c	0.09	0.20	.0035	.008
D	SEE VARIATIONS		SEE VARIATIONS	
E	6.40 BASIC		0.252 BASIC	
E1	4.30	4.50	.169	.177
e	0.65 BASIC		0.0256 BASIC	
L	0.45	0.75	.018	.030
N	SEE VARIATIONS		SEE VARIATIONS	
$\alpha$	0°	8°	0°	8°
aaa	--	0.10	--	.004

VARIATIONS

N	D mm.		D (inch)	
	MIN	MAX	MIN	MAX
24	7.70	7.90	.303	.311

Reference Doc.: JEDEC Publication 95, MO-153  
10-0035

4.40 mm. Body, 0.65 mm. pitch TSSOP  
(173 mil) (0.0256 Inch)

Ordering Information

2510CGLFT

Example:

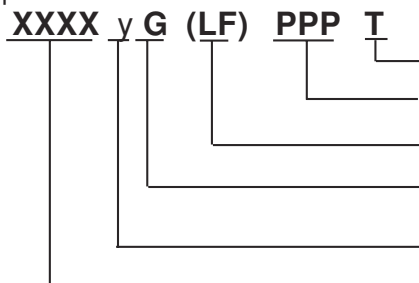

- Designation for tape and reel packaging
- Pattern Number (2 or 3 digit number for parts with ROM code patterns)
- Lead Free, RoHS Compliant (Optional)
- Package Type  
G = TSSOP
- Revision Designator (will not correlate with datasheet revision)
- Device Type