



Chipsmall Limited consists of a professional team with an average of over 10 year of expertise in the distribution of electronic components. Based in Hongkong, we have already established firm and mutual-benefit business relationships with customers from,Europe,America and south Asia,supplying obsolete and hard-to-find components to meet their specific needs.

With the principle of “Quality Parts,Customers Priority,Honest Operation,and Considerate Service”,our business mainly focus on the distribution of electronic components. Line cards we deal with include Microchip,ALPS,ROHM,Xilinx,Pulse,ON,Everlight and Freescale. Main products comprise IC,Modules,Potentiometer,IC Socket,Relay,Connector.Our parts cover such applications as commercial,industrial, and automotives areas.

We are looking forward to setting up business relationship with you and hope to provide you with the best service and solution. Let us make a better world for our industry!



Contact us

Tel: +86-755-8981 8866 Fax: +86-755-8427 6832

Email & Skype: info@chipsmall.com Web: www.chipsmall.com

Address: A1208, Overseas Decoration Building, #122 Zhenhua RD., Futian, Shenzhen, China



BK PRECISION[®]

Model: 2511, 2512, 2515, 2516

2510 Series Handheld Digital Storage Oscilloscopes

USER MANUAL



Safety Summary

The following safety precautions apply to both operating and maintenance personnel and must be observed during all phases of operation, service, and repair of this instrument. Before applying power, follow the installation instructions and become familiar with the operating instructions for this instrument.

If this device is damaged or something is missing, contact the place of purchase immediately.

This manual contains information and warnings that must be followed to ensure safe operation as well as maintain the meter in a safe condition.

DO NOT OPERATE IN AN EXPLOSIVE ATMOSPHERE

Do not operate the instrument in the presence of flammable gases or fumes. Operation of any electrical instrument in such an environment constitutes a definite safety hazard.

KEEP AWAY FROM LIVE CIRCUITS

Instrument covers must not be removed by operating personnel. Component replacement and internal adjustments must be made by qualified maintenance personnel. Disconnect the power cord before removing the instrument covers and replacing components. Under certain conditions, even with the power cable removed, dangerous voltages may exist. To avoid injuries, always disconnect power and discharge circuits before touching them.

DO NOT SUBSTITUTE PARTS OR MODIFY THE INSTRUMENT

Do not install substitute parts or perform any unauthorized modifications to this instrument. Return the instrument to B&K Precision for service and repair to ensure that safety features are maintained.

WARNINGS AND CAUTIONS

WARNING and ***CAUTION*** statements, such as the following examples, denote a hazard and appear throughout this manual. Follow all instructions contained in these statements.

A ***WARNING*** statement calls attention to an operating procedure, practice, or condition, which, if not followed correctly, could result in injury or death to personnel.

A **CAUTION** statement calls attention to an operating procedure, practice, or condition, which, if not followed correctly, could result in damage to or destruction of part or all of the product.

NOTE:

Voltage ratings are given as “working voltage”. They should be read as Vac-rms (50 – 60 Hz) for AC sine wave applications and as Vdc for DC applications.

WARNING

- Do not connect the scope probes and DMM leads simultaneously.
- Before using the DMM functions, disconnect all scope probes. Likewise, disconnect all DMM test leads before using any scope functions.
- When not in use, remove all scope probes, DMM test leads, and the USB cable.

WARNING

To avoid potential fire or shock hazard:

- Disconnect all probes, leads, power adapter, and USB cable before opening the battery cover.
- Do not turn on the instrument while the battery cover is removed.
- Use only the included insulated probes, test leads, and power adapter supplied with the instrument.
- Use only the battery pack supplied with the instrument or approved by us. Do not use other substitutes.
- For AC power operation, always connect the adapter to the outlet first before connecting to the instrument.
- Observe all markings and ratings on the instrument before connecting to the instrument.
- While making measurements, verify that the performance ratings of instruments and accessories that are used meet the correct safety levels of the instrument.

- Do not insert metal objects into any of the connectors.

WARNING

- Do not use any exposed metal BNC or banana plug connectors with the instrument. Use only the insulated accessories supplied with the instrument.
- Do not connect the USB cable while the instrument is not in use. Keep the cable away from all probes and test leads.
- Always connect the probes or test leads to the instrument first before connecting to any other device under test (DUT). To remove, disconnect them from the DUT first before disconnecting from the instrument.
- Do not operate the instrument in wet environments.
- For high voltage testing, keep the BNC connectors and the entire instrument dry.
- Do not apply input voltages above the instrument and the probe's voltage rating.

CAUTION

- Always cover the DC power input and USB ports on the side of the instrument with the rubber lid when not in used.
- Do not use any abrasive chemicals or volatile liquid when cleaning the instrument. If using a cloth dampened with water, allow the instrument to completely dry before reconnecting it.

Compliance Statements

Disposal of Old Electrical & Electronic Equipment (Applicable in the European Union and other European countries with separate collection systems)



This product is subject to Directive 2002/96/EC of the European Parliament and the Council of the European Union on waste electrical and electronic equipment (WEEE), and in jurisdictions adopting that Directive, is marked as being put on the market after August 13, 2005, and should not be disposed of as unsorted municipal waste. Please utilize your local WEEE collection facilities in the disposition of this product and otherwise observe all applicable requirements.

CE Declaration of Conformity

The power supply meets the requirements of 2006/95/EC Low Voltage Directive and 2004/108/EC Electromagnetic Compatibility Directive with the following standards.

Low Voltage Directive

- EN 61010-1: 2010
Safety requirements for electrical equipment for measurement, control, and laboratory use-Part 1: General requirements
- EN 61010-031: 2002+A1: 2008
Part 31: Safety requirements for hand-held probe assemblies for electrical measurement and test

EMC Directive

- EN 61326-1: 2006
- EN 61000-3-2: 2006+A2: 2009
- EN 61000-3-3: 2008

Safety Symbols



Electrical Shock hazard.



Refer to the operating user manual for warning information to avoid hazard or personal injury and prevent damage to instrument.



This symbol shows that the switch is a power switch located at the front panel. Pressing this button turns on the oscilloscope, and holding it down for a few seconds turns off the oscilloscope.

CATI

Category I overvoltage conditions.

Measurement instruments whose measurement inputs are not intended to be connected to the mains supply. The voltages in the environment are typically derived from a limited-energy transformer or a battery.

CATII

Category II overvoltage conditions.

Measurement instruments whose measurement inputs are meant to be connected to the mains supply at a standard wall outlet or similar sources.

CATIII

Category III overvoltage conditions.

Measurement instruments whose measurement inputs are meant to be connected to the mains installation of a building.



Maximum Input Voltages

Oscilloscope Inputs

- Maximum input voltage to CH1 and CH2 BNC direct(1:1) - CATII 300V RMS, CATI 150V RMS

- Maximum input voltage to CH1 and CH2 BNC via 10:1 probe PR250SA (included with models 2515 and 2516) - CATII 1000V RMS, CATIII 600V RMS
- Maximum input voltage to CH1 and CH2 BNC via 1X/10X probe PR150SA (included with models 2511 and 2512) – CATII 300V RMS
- Scope Input – CATII 300V RMS
- Meter Input – CATII 600V RMS, CATIII 300V RMS

NOTE:

Voltage ratings are given as “working voltage”. They should be read as Vac-rms (50 – 60 Hz) for AC sine wave applications and as Vdc for DC applications.



Maximum Floating Voltage

These apply to models 2515 and 2516 only, which have channel isolation that allows for floating measurements.

- Maximum floating voltage from input CH1 and CH2 to earth ground – CATII 1000V RMS, CATIII 600V RMS
- Maximum floating voltage between CH1 and CH2 reference – CATII 1000V RMS, CATIII 600V RMS

The following applies to all models:

- Maximum floating voltage from multimeter reference to earth ground – CATII 600V RMS, CATIII 300V RMS

NOTE:

Voltage ratings are given as “working voltage”. They should be read as Vac-rms (50 – 60 Hz) for AC sine wave applications and as Vdc for DC applications.

Environmental Conditions

The instrument may be operated in the following environment.

| | |
|-----------------------|--------------------|
| Operating Environment | 0 °C to 40 °C |
| Storage Humidity | 0 – 85% R.H. |
| Storage Environment | -20 °C to +70 °C |
| Pollution degree | Pollution degree 2 |
| Measurement Category | CAT II, CAT III |

Table of Contents

| | |
|---------------------------------------|----|
| Safety Summary | 2 |
| 1 General Information | 16 |
| 1.1 Product Overview..... | 16 |
| 1.2 Package Contents | 17 |
| 1.3 Front Panel Overview..... | 18 |
| Front Panel Description | 18 |
| 1.4 Top View..... | 20 |
| 1.5 Rear Panel Overview | 20 |
| 1.6 Side Panel Overview..... | 21 |
| Side Panel Description | 21 |
| 1.7 Display Overview..... | 22 |
| Oscilloscope Display..... | 22 |
| Digital Multimeter Display | 24 |
| Recorder/Trend Plot Display..... | 25 |
| 1.8 Protection Fuse | 26 |
| 1.9 Isolation (Model 2515/2516) | 26 |
| 1.10 Probes..... | 27 |
| 2 Getting Started..... | 28 |
| 2.1 Input Power Requirements | 28 |
| External Power Operation | 28 |
| Battery Operation | 29 |
| 2.2 Tilt Stand..... | 30 |
| 2.3 Power On Device | 30 |
| 2.4 Perform Self-Calibration..... | 31 |
| 2.5 Set to Factory Default | 32 |
| 2.6 Configure Date and Time | 35 |
| 2.7 Probe Compensation..... | 36 |
| 3 Using the Oscilloscope | 39 |

| | | |
|-----|---|----|
| 3.1 | Channel Selection..... | 39 |
| 3.2 | Channel Menu | 39 |
| | Channel Coupling | 41 |
| | Bandwidth Limit | 41 |
| | Vertical Scale..... | 41 |
| | Probe Attenuation Scale | 41 |
| | Invert Waveform..... | 41 |
| | Digital Filter | 42 |
| 3.3 | Automatic Settings and Run/Stop Mode | 42 |
| | Auto Setting | 42 |
| | Run/Stop Mode..... | 43 |
| 3.4 | Scope Menu..... | 44 |
| | Acquire Menu | 44 |
| | Display Menu | 45 |
| | Math Menu | 49 |
| | Horizontal System | 54 |
| | Vertical System | 60 |
| | Reference Waveform Menu | 62 |
| 3.5 | Trigger System..... | 64 |
| | Adjust Trigger Level..... | 64 |
| | Edge Trigger | 65 |
| | Pulse Trigger..... | 67 |
| | Video Trigger..... | 69 |
| | Slope Trigger | 72 |
| | Alternative Trigger | 74 |
| 3.6 | Connecting External Memory | 75 |
| 3.7 | Save/Recall Function | 76 |
| | Saving and Recalling Setups and Waveforms | 78 |
| | Saving Screen Capture | 83 |
| | Saving Waveform Data | 83 |

| | | |
|-----|--|-----|
| 3.8 | Utility Menu..... | 84 |
| | Check System Information..... | 86 |
| | Enable/Disable Key Sound..... | 87 |
| | Enable/Disable Frequency Counter..... | 87 |
| | Set the Language..... | 88 |
| | Updating Firmware..... | 88 |
| | Set Screen Saver..... | 90 |
| | Waveform Record Function..... | 90 |
| | Playback Recorded Waveform..... | 93 |
| 3.9 | Measurement and Cursor Functions..... | 94 |
| | Measurement Functions..... | 94 |
| | Cursor Functions..... | 101 |
| 4 | Using the Digital Multimeter..... | 109 |
| 4.1 | DC and AC Voltage Measurements..... | 110 |
| | DC Voltage Measurement..... | 111 |
| | AC Voltage Measurements..... | 113 |
| 4.2 | DC and AC Current Measurements..... | 114 |
| | DC Current Measurements..... | 115 |
| | Make AC Current Measurements..... | 117 |
| 4.3 | Make Resistance Measurements..... | 119 |
| 4.4 | Make Diode Measurements..... | 121 |
| 4.5 | Continuity Test..... | 122 |
| 4.6 | Make Capacitance Measurements..... | 124 |
| 4.7 | Using Trend Plot..... | 126 |
| 5 | Using the Recorder..... | 126 |
| | Scope Trend Plot..... | 126 |
| | Record Data with Trend Plot..... | 128 |
| | Save Recorded Data to External Memory..... | 131 |
| | Scope Recorder..... | 132 |
| | Configure Record Options..... | 134 |

| | |
|--|-----|
| Start Scope Recording..... | 134 |
| Playback Scope Recording | 136 |
| Meter Trend Plot..... | 137 |
| Record Data with Trend Plot..... | 140 |
| Save Recorded Data to External Memory..... | 141 |
| 6 Remote Communication | 143 |
| 7 Troubleshooting Guide | 144 |
| System Message Prompts and Instructions..... | 144 |
| Frequently Asked Questions | 145 |
| Oscilloscope | 145 |
| Multimeter | 146 |
| 8 Specifications | 147 |
| Oscilloscope Specifications | 147 |
| Maximum Input Voltages..... | 151 |
| Multimeter Specifications..... | 153 |
| Recorder Specifications | 155 |
| General Specifications | 156 |
| 11 Maintenance | 157 |
| Cleaning..... | 157 |
| SERVICE INFORMATION | 158 |
| LIMITED THREE-YEAR WARRANTY | 159 |

List of Figures

| | |
|--|----|
| Figure 1 - Front Panel View | 18 |
| Figure 2 - Top View | 20 |
| Figure 3 - Rear View | 20 |
| Figure 4 - Side View..... | 21 |
| Figure 5 - Oscilloscope Display..... | 22 |
| Figure 6 - Multimeter Display | 24 |
| Figure 7 – Scope Trend Plot Display..... | 25 |
| Figure 8 - Connecting Power Adapter..... | 28 |
| Figure 9 - Installing Battery..... | 29 |
| Figure 10 - Boot Screen..... | 31 |
| Figure 11 - Utility Menu 4/4..... | 35 |
| Figure 12 - Date/Time Menu..... | 35 |
| Figure 13 - Date and Time Display | 36 |
| Figure 14 - Channel Display..... | 39 |
| Figure 15 - Auto Setting | 43 |
| Figure 16 - XY Mode..... | 47 |
| Figure 17 - Inverted Screen Color | 48 |
| Figure 18 - Grid and Axes Display | 48 |
| Figure 19 - Axes Only Display..... | 49 |
| Figure 20 - No Grid and Axes Display..... | 49 |
| Figure 21 - Math Waveform Display..... | 51 |
| Figure 22 - FFT Full Screen (left), Split Screen (right) | 53 |
| Figure 23 - Horizontal Position Reference Marker | 55 |
| Figure 24 - Horizontal Scale Indicator..... | 55 |
| Figure 25 - Horizontal Position Indicator | 56 |
| Figure 26 - Horizon Menu | 56 |
| Figure 27 - Delay Scan..... | 57 |
| Figure 28 - Normal Memory Depth..... | 58 |
| Figure 29 - Long Memory Depth..... | 58 |
| Figure 30 - Vertical Position Markers..... | 60 |
| Figure 31 - Vertical Position Indicator | 61 |
| Figure 32 - Fine Control Volts/Div..... | 62 |
| Figure 33 - Reference Waveforms Display..... | 63 |
| Figure 34 - Trigger Level Display | 64 |
| Figure 35 - Hold Off Time Indicator | 67 |
| Figure 36 - Pulse Width Trigger Condition Display | 69 |
| Figure 37 - USB Drive Detected..... | 76 |

| | |
|---|-----|
| Figure 38 - USB Drive Removed | 76 |
| Figure 39 - Directory Menu 1/2 | 79 |
| Figure 40 - Create Directory Name | 80 |
| Figure 41 - Save Progress | 81 |
| Figure 42 - Save Successfully..... | 81 |
| Figure 43 - Overwrite Warning | 82 |
| Figure 44 - Subdirectory View..... | 83 |
| Figure 45 - System Information Display..... | 87 |
| Figure 46 - Frequency Counter Display..... | 88 |
| Figure 47 - Record Frame Indicator | 92 |
| Figure 48 - Recording Finished..... | 92 |
| Figure 49 - All Voltage Measurements Display | 100 |
| Figure 50 - All Time Measurements Display | 100 |
| Figure 51 - All Delay Measurements Display | 100 |
| Figure 52 - All Measurements Display | 101 |
| Figure 53 - Manual Voltage Cursor | 103 |
| Figure 54 - Manual Time Cursor | 104 |
| Figure 55 - Track Cursor Display | 106 |
| Figure 56 - Auto Cursor Measuring Vpp | 107 |
| Figure 57 - Auto Cursor Measuring Period | 108 |
| Figure 58 - Multimeter Display | 109 |
| Figure 59 - Out of Range | 112 |
| Figure 60 - Connection for DC Voltage Measurement | 113 |
| Figure 61 - Connection for AC Voltage Measurement..... | 114 |
| Figure 62 - Connection for Low DC Current Measurement..... | 116 |
| Figure 63 - Connection for Higher DC Current Measurement..... | 117 |
| Figure 64 - Connection for Low AC Current Measurement..... | 118 |
| Figure 65 - Connection for Higher AC Current Measurement..... | 118 |
| Figure 66 - Connection for Resistance Measurement | 120 |
| Figure 67 - Connection for Diode Measurement..... | 122 |
| Figure 68 - Continuity Test..... | 123 |
| Figure 69 - Connection for Continuity Test..... | 124 |
| Figure 70 - Capacitance Measurement..... | 124 |
| Figure 71 - Connection for Capacitance Measurement..... | 126 |
| Figure 72 - Scope Recorder External Save Mode..... | 135 |
| Figure 73 - Recording Display | 135 |
| Figure 74 - Playback Scope Recording | 136 |
| Figure 75 - Meter Trend Plot Display..... | 138 |

1 General Information

1.1 Product Overview

The B&K Precision 2510 series handheld digital storage oscilloscope combines the functions of a digital storage oscilloscope, digital multimeter, and a recorder into one portable form factor. The oscilloscope's bandwidth is up to 100 MHz with a real time sampling rate of up to 1 GSa/s. With up to 2M points of deep memory, it allows for capturing more details of a signal for analysis. Additionally, the multimeter provides most of the standard measurement functions, which include AC and DC voltage, AC and DC current, resistance, capacitance, diode, and continuity. The recorder function allows users to quickly capture data without the need to connect to a computer.

Features:

- 5.7" color TFT LCD Display
- Oscilloscope, multimeter, and recorder functionality (trend plot and waveform recorder)
- Fully isolated oscilloscope channels (models 2515 and 2516 only) and isolated multimeter inputs
- 6000-count multimeter
- Multimeter supports voltage, current, resistance, capacitance, diode, and continuity measurements
- Supports scope and multimeter measurement parameters trend plot and scope waveform recorder
- 32 auto measurement functions
- Store/recall 2 groups of reference waveforms, 20 groups of common waveforms, 10 groups of instrument settings
- USB interface for remote communication

1.2 Package Contents

Please inspect the instrument mechanically and electrically upon receiving it. Unpack all items from the shipping carton, and check for any obvious signs of physical damage that may have occurred during transportation. Report any damage to the shipping agent immediately. Save the original packing carton for possible future reshipment. Every oscilloscope is shipped with the following contents:

- **1 x 2510 series handheld digital storage oscilloscope**
- **1 x 7.4 V Li-Ion battery (inside battery compartment)**
- **1 x User Manual**
- **2 x 10X CATIII 600 V probes (models 2515 and 2516 only)**
- **2 x 1X/10X CATII 300 V probes (models 2511 and 2512 only)**
- **1 x Pair of DMM test leads**
- **1 x Carrying case and straps**
- **1 x USB cable**
- **1 x Probe compensation connector**
- **1 x AC power adapter**
- **1 x Certificate of Calibration**

Verify that all items above are included in the shipping container. If anything is missing, please contact B&K Precision.

1.3 Front Panel Overview

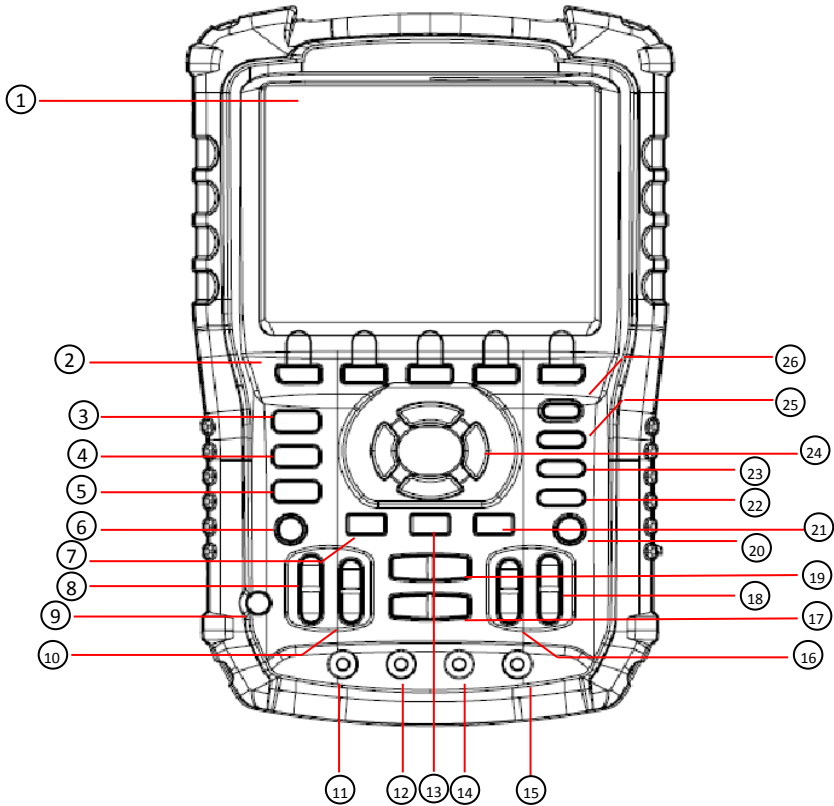

Figure 1 - Front Panel View

Front Panel Description

| | | |
|---|----------|---|
| ① | | LCD display |
| ② | F1 - F5 | Menu function keys |
| ③ | Scope | Scope function button |
| ④ | Meter | Multimeter function button |
| ⑤ | Recorder | Recorder function button <i>Trend plot and waveform recorder</i> |
| ⑥ | CH1 | Channel 1 button (scope) |
| ⑦ | Trigger | Trigger Menu button |

| | | |
|----|--|--|
| 8 | | Channel 1 Volts/div range keys (scope) |
| 9 | | Power On/Off |
| 10 | | Channel 1 vertical position keys (scope) |
| 11 | | 10 A current input port (multimeter) |
| 12 | | mA current input port (multimeter) |
| 13 | | User/Options Menu |
| 14 | | COM input port (multimeter) |
| 15 | | Voltage/Resistance/Capacitance input port (multimeter) |
| 16 | | Channel 2 vertical position keys (scope) |
| 17 | | Horizontal position keys (scope) |
| 18 | | Channel 2 Volts/div range keys (scope) |
| 19 | | Horizontal Timebase keys (scope) |
| 20 | | Channel 2 button (scope) |
| 21 | | Save/Recall Menu button |
| 22 | | Cursor/Measurement function button (scope) |
| 23 | | Run/Stop button; also acts as a Single button when trigger mode is set to Single (scope) |
| 24 | | Arrow selection keys |
| 25 | | Auto button (scope) |
| 26 | | Menu On/Off button |

1.4 Top View

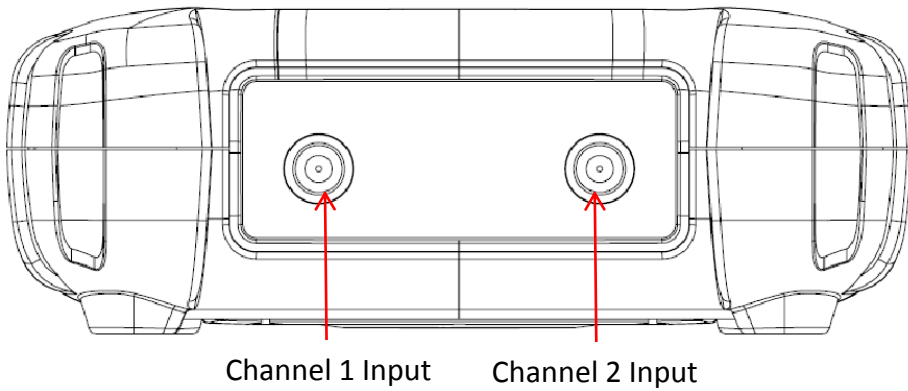

Figure 2 - Top View

1.5 Rear Panel Overview

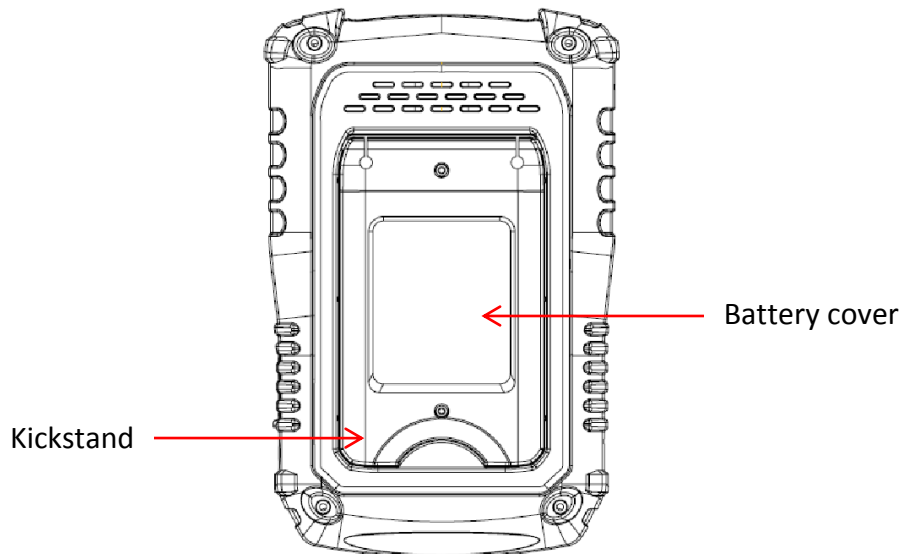

Figure 3 - Rear View

1.6 Side Panel Overview

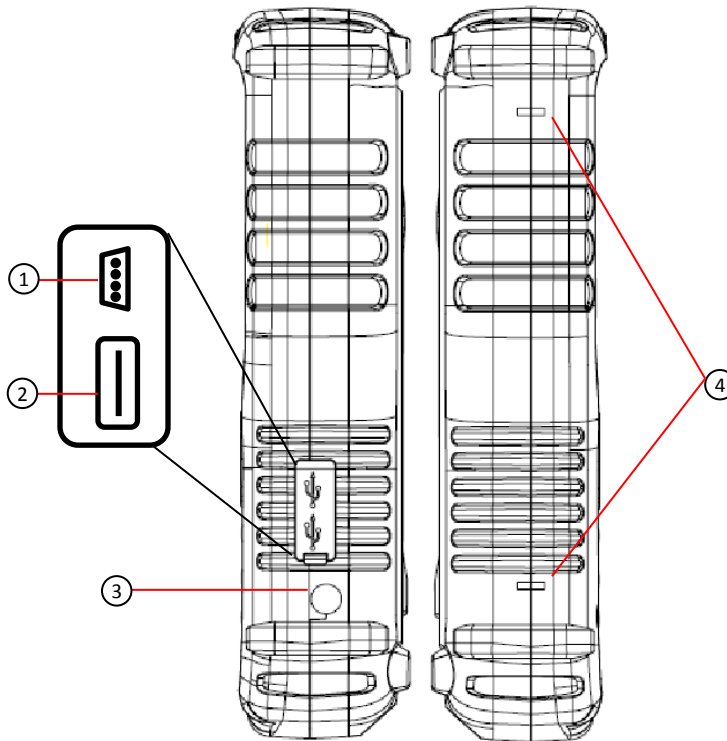

Figure 4 - Side View

Side Panel Description

-
- ① MiniUSB device port
For probe compensation and remote interface
-
- ② USB host port
For saving/recalling waveforms and instrument setups
-
- ③ External power adapter input
-
- ④ Mount holes for carry handle
-

1.7 Display Overview

Oscilloscope Display

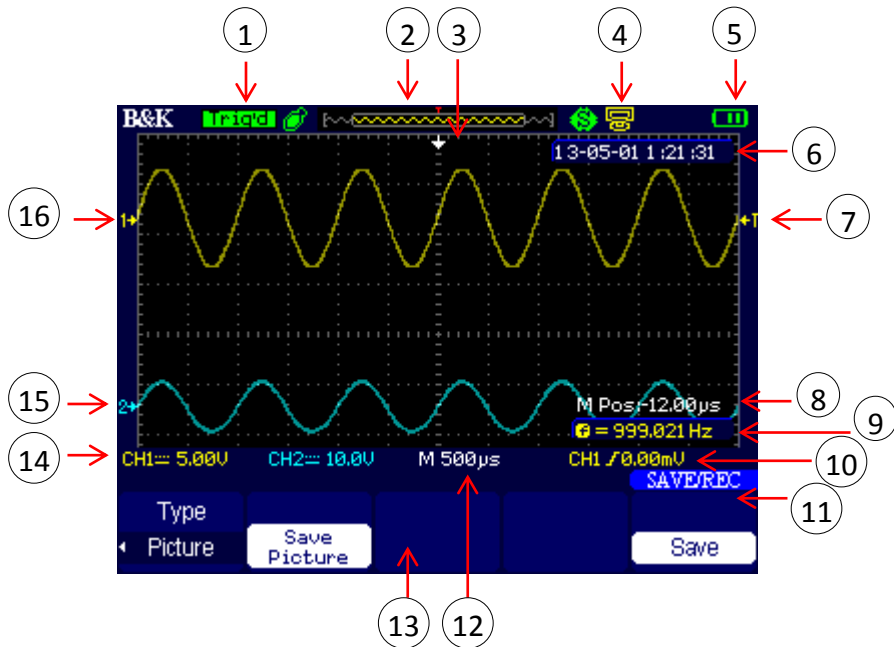

Figure 5 - Oscilloscope Display



-
- ① Trigger status
- Armed – Instrument is acquiring pre-trigger data. All triggers are ignored.
 - Ready – All pre-trigger data has been acquired and the instrument is ready to accept a trigger
 - Trig'd – Instrument has triggered and is acquiring post-trigger data
 - Stop – Instrument has stopped acquiring waveform data
 - Auto – Instrument is in auto mode and is acquiring waveforms without trigger
 - Scan – Instrument is acquiring and displaying waveform data continuously. This mode is automatically set for when
-

timebase is slow enough in which requires a longer time to “scan” to acquire the entire signal on display



② Displays the position of the present waveform window in internal memory

③ Horizontal trigger position marker

④ USB mode indicator

-  Side USB interface is configured for PC communication
 -  Side USB interface is configured for printer (not available)
-

⑤ Battery indicator

-  - Battery charging
 -  - Battery empty
 -  - Battery full
-

⑥ Time and date display

⑦ Trigger position marker

⑧ Horizontal trigger position

⑨ Trigger signal frequency



⑩ Trigger voltage indicator

⑪ Menu header/label

⑫ Horizontal timebase

⑬ Menu display

⑭ Signal coupling

-  - DC coupling
-  - AC coupling
-  - GND(ground) coupling

Volts/div indicator

Bandwidth limit On/Off indicator

-  B - Bandwidth limit ON
-

⑮ Channel 2 identifier

⑯ Channel 1 identifier

Digital Multimeter Display

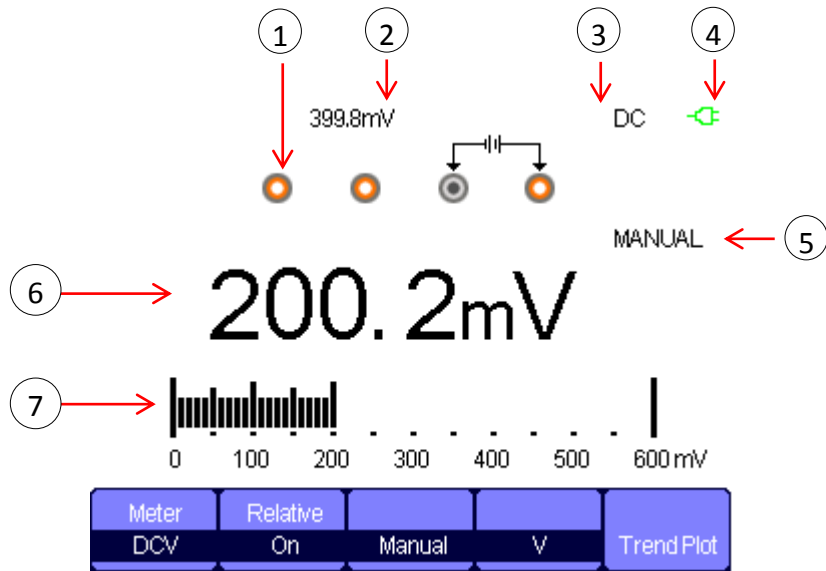

Figure 6 - Multimeter Display

| | |
|---|--|
| ① | Input port indicator <i>Highlights which port to connect to for selected measurement function</i> |
| ② | Relative value display |
| ③ | Measurement type |
| ④ | AC power indicator |
| ⑤ | Operation mode |
| ⑥ | Measurement reading display |
| ⑦ | Measurement bar graph |

Recorder/Trend Plot Display

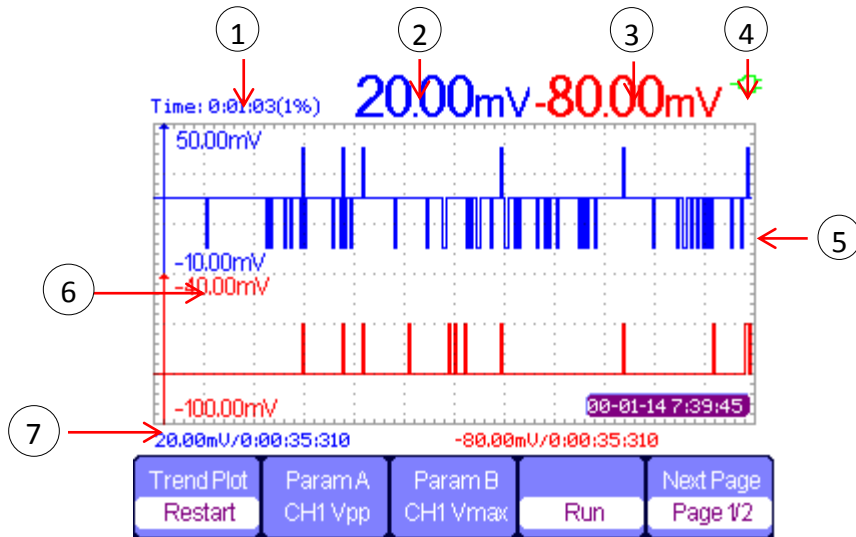

Figure 7 – Scope Trend Plot Display

| | |
|---|---------------------------------|
| ① | Recording/Trend Plot time |
| ② | Parameter A measured value |
| ③ | Parameter B measured value |
| ④ | Battery indicator |
| ⑤ | Parameter A measured data plot |
| ⑥ | Parameter B measured data plot |
| ⑦ | Current measured value and time |