



Chipsmall Limited consists of a professional team with an average of over 10 year of expertise in the distribution of electronic components. Based in Hongkong, we have already established firm and mutual-benefit business relationships with customers from,Europe,America and south Asia,supplying obsolete and hard-to-find components to meet their specific needs.

With the principle of “Quality Parts,Customers Priority,Honest Operation,and Considerate Service”,our business mainly focus on the distribution of electronic components. Line cards we deal with include Microchip,ALPS,ROHM,Xilinx,Pulse,ON,Everlight and Freescale. Main products comprise IC,Modules,Potentiometer,IC Socket,Relay,Connector.Our parts cover such applications as commercial,industrial, and automotives areas.

We are looking forward to setting up business relationship with you and hope to provide you with the best service and solution. Let us make a better world for our industry!



Contact us

Tel: +86-755-8981 8866 Fax: +86-755-8427 6832

Email & Skype: info@chipsmall.com Web: www.chipsmall.com

Address: A1208, Overseas Decoration Building, #122 Zhenhua RD., Futian, Shenzhen, China





Fibrlok™ Splice Organizer Tray 2524

Instructions

Contents

| | | |
|-----|---|----|
| 1.0 | General | 4 |
| 2.0 | Kit Contents | 4 |
| 3.0 | Prepare the Cables and Closure for Splicing | 4 |
| 4.0 | Install the Buffer Tubes into the Tray | 6 |
| 5.0 | Splice the Fibers..... | 8 |
| 6.0 | Install Additional Trays..... | 10 |
| 7.0 | Tray Identification..... | 11 |

1.0 General

The 3M™ Fibrlok™ Splice Organizer Tray 2524 stores up to 24 3M™ Fibrlok™ Splices and the respective buffer tubes and fibers. A 4" (102 mm) minimum bend diameter is maintained in each tray. Also, the trays hinge together for individual tray access in a stack.

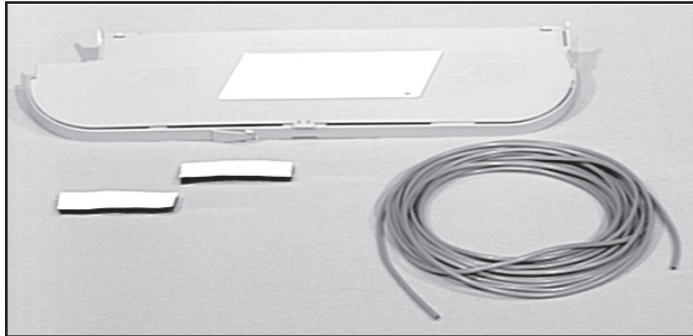

2.0 Kit Contents

Note: *Visually inspect all components. If any component is missing or appears damaged, do not install and call 3M customer service at 1-800-426-8688 for a replacement product.*

2.01 Additional Materials Required:

Vinyl Tape
Snips
Measuring Tape
AT&T Unit Splitter (required with AT&T light guide cable only)

2.02 Compatible Closures:

3M™ Fiber Optic Splice Case 2178
3M™ Fiber Optic Splice Closure 2177 with the 2196 universal organizer bracket
3M™ Fiber Optic PST Pedestal Splice Closure 2190 with the 2196 universal organizer bracket
Corning 8" (203 mm) Fiber Optic Splice Closure

2.03 Maximum Capacity in 3M Closures:

| Closure | Number of Trays |
|--------------------|-----------------|
| 2178 | 8 |
| 2178 plus one 2181 | 12* |
| 2178 plus two 2181 | 15* |
| 2177 | 4** |
| 2190 | 2** |

* No space clamp needed.

** Use 2196 bracket.

Note: *The following procedure is shown with the 2178 fiber optic splice closure. Certain steps may vary with other closures.*

⚠ WARNING

Fiber ends and unmated connectors may emit INVISIBLE laser or LED radiation. Avoid direct eye exposure to the beam. Do not inspect with magnifying instruments. Cap plugs should be kept on all unmated connectors.

Note: *The following procedures must be followed prior to installing the 3M™ Splice Organizer Tray 2524 .*

3.0 Prepare the Cables and Closure for Splicing

- 3.01 Prepare the cables to be spliced per the company practice to expose 8 feet (2.4 m) of cable buffer tubes.
- 3.02 Clean the sealant from buffer tube(s) per company practice.

Note: *Carefully follow health and safety information given on cleaning solvent container label or Material Safety Data Sheet.*

- 3.03 If the cable is a ribbon, unitue or slotted core, loose tubes from a unit splitter kit will be placed over the fibers to be spliced for protection.
- 3.04 Secure the cables to the closure per the closure practice.
- 3.05 Lay one complete coil of buffer tube(s) in the closure base in a **COUNTERCLOCKWISE** direction. Buffer tubes should exit the closure in the corner where they will enter the splice trays.
- 3.06 Trim the buffer tubes (without cutting the fibers) to the middle of the closure. Leave at least 75% of one coil buffer tubing intact.
- 3.07 Clean the grease from the fiber per company practice.
- 3.08 Cut the supplied tubing into 12" (305 mm) pieces.
- 3.09 Slide a segment of tubing over the fibers until it contacts the buffer tube end. No more than twelve 250 μm fibers or four 900 μm fibers should be placed into a tube.
- 3.10 Slide the segment of tubing over the buffer tube about 1" (25 mm) and secure with two wraps of vinyl tape.

3.11 Mount the 3M™ Universal Organizer Adapter in the closure base.

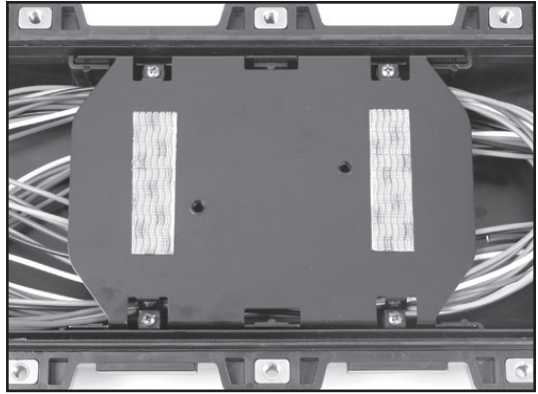

3.12 Cut the 3M™ Dual-Lok™ Fastener Material to fit the four flat pads on the tray bottom. Remove protective liner and adhere.

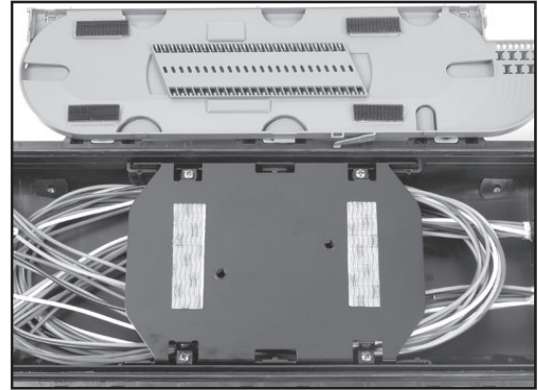

3.13 Center the tray over the adapter and press down to secure.

⚠ WARNING

Fiber ends and unmated connectors may emit INVISIBLE laser or LED radiation. Avoid direct eye exposure to the beam. Do not inspect with magnifying instruments. Cap plugs should be kept on all unmated connectors.

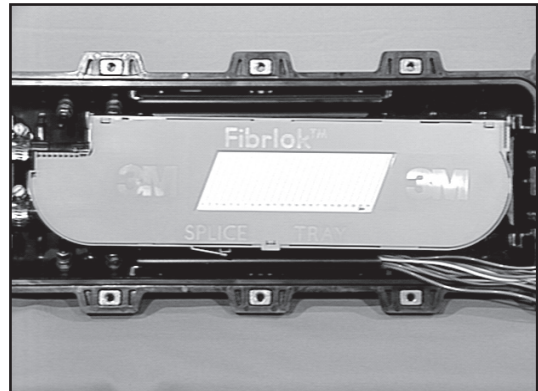

4.0 Install the Buffer Tubes into the Tray

4.01 To remove cover, unlatch and grasp either corner. Pull straight and rotate simultaneously until both hinges are disengaged.

4.02 Identify fibers to be spliced.

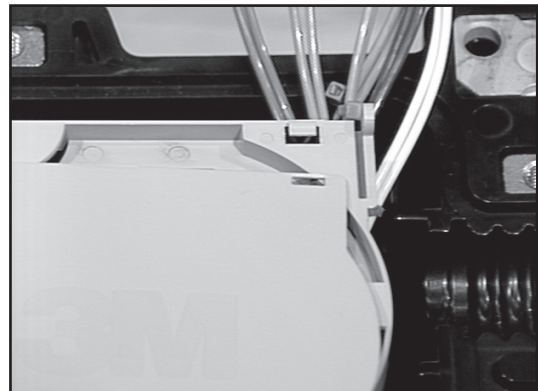

- 4.03 Lay the buffer tube ends over the channels. If tubes are too long to fit in channels, trim excess off. **DO NOT CUT FIBERS.**

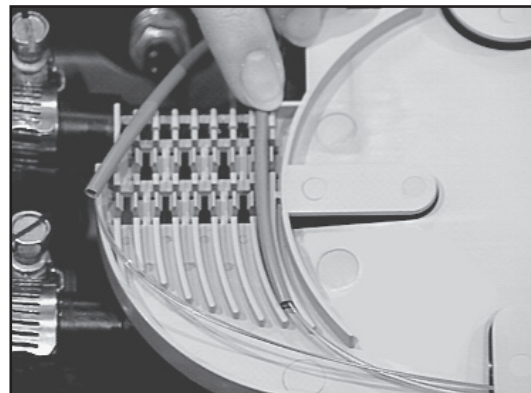

- 4.04 Press the buffer tube into the channel to secure. The buffer tube should stop within 1/4" (6 mm) of the channel end.

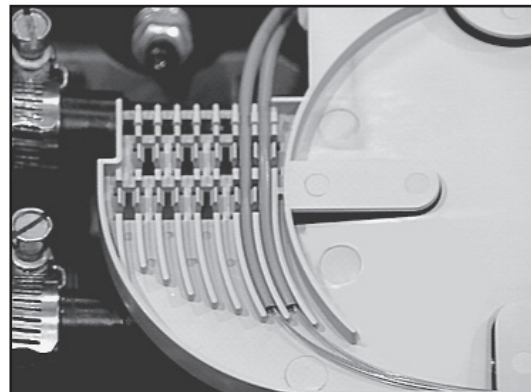

- 4.05 Lay at least one complete loop of fiber from the first buffer tube on the tray with the fiber ends crossing the front "CUT HERE" mark.



- 4.06 Now cut the fiber ends at the mark. Be sure to cut ONLY the fiber ends.

- 4.07 Remove the cut fibers from the tray, but leave the buffer tube installed.

- 4.08 Secure the buffer tube, from the second cable, which will now be spliced to those just cut.

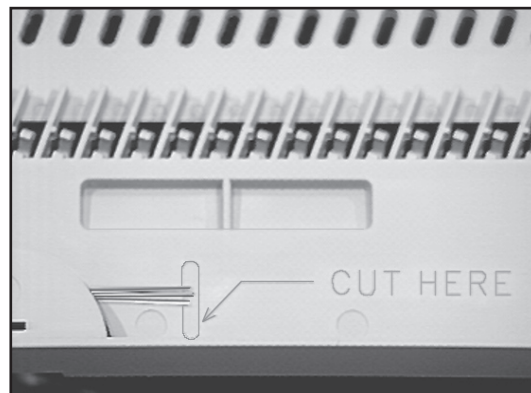

- 4.09 Lay at least 1 1/2 loops of fiber from the first buffer tube of the second cable on the tray with the fiber ends crossing the back "CUT HERE" mark.

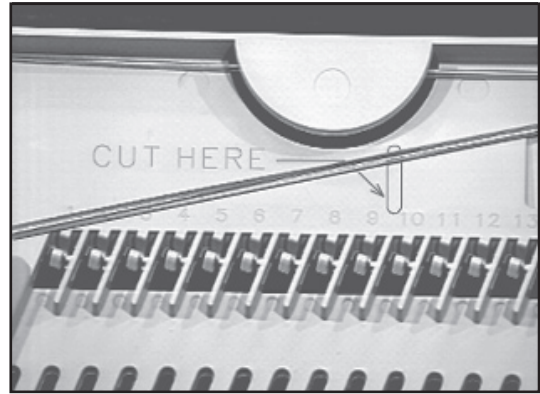

- 4.10 Now cut the fiber ends at the mark. Be sure to cut ONLY the fiber ends.

- 4.11 Remove the cut fibers from the tray, but leave the buffer tube installed.

- 4.12 For remaining buffer tubes repeat steps 4.01 through 4.11.

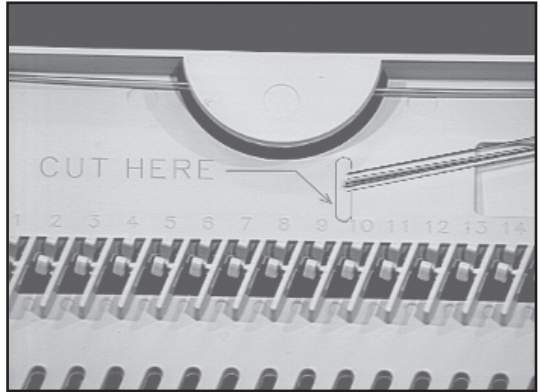

5.0 Splice the Fibers

⚠ WARNING

Fiber ends and unmated connectors may emit INVISIBLE laser or LED radiation. Avoid direct eye exposure to the beam. Do not inspect with magnifying instruments. Cap plugs should be kept on all unmated connectors.

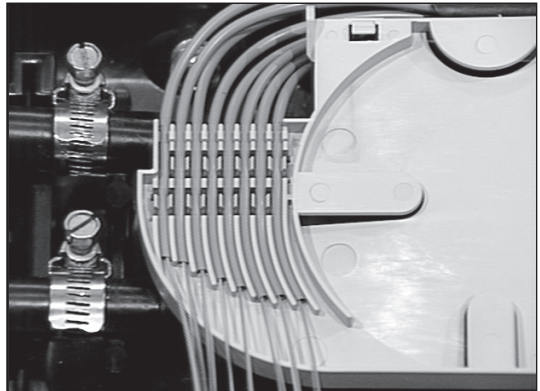

- 5.01 Store the first two fibers to be spliced under the tray tabs.

- 5.02 Remove the minimum length of fiber required to prepare and splice the fibers.

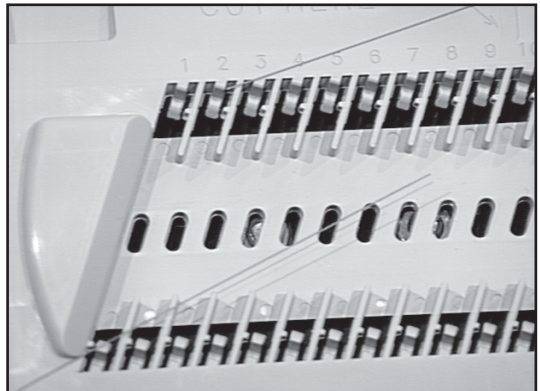

- 5.03 Place the splicing tool in close proximity to the splice tray. Prepare and splice the first pair of fibers.

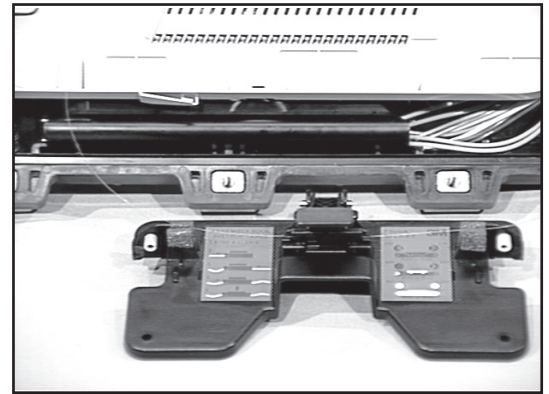

- 5.04 Lay the splice on top of the pocket that it will snap into. Place the fibers around the perimeter of the tray under the tray tabs. If 900 micron fiber is being spliced to 250 micron fiber, place the 900 micron fiber into the tray before placing splice in position. This removes torsional load from the 900 micron fiber.

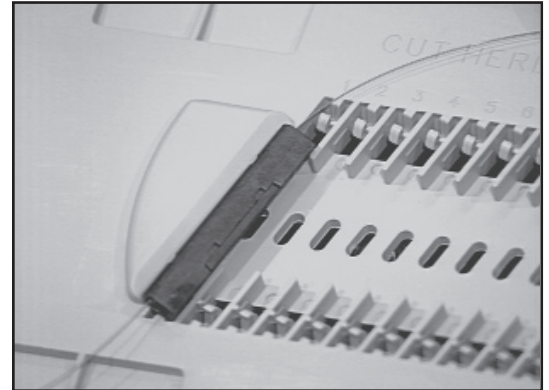

- 5.05 Prior to placing the splice into the pocket, observe how the splice lays in its relaxed state. Rotate the splice through the smallest possible angle. Snap splice into pocket cap side down.

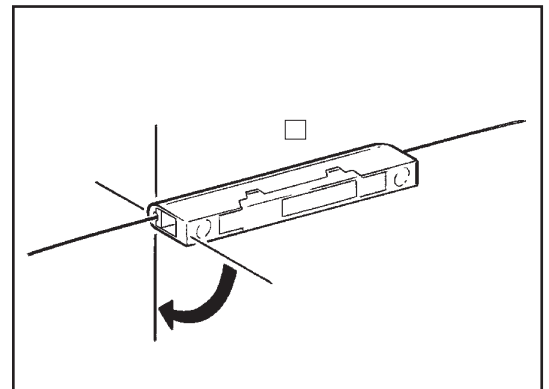
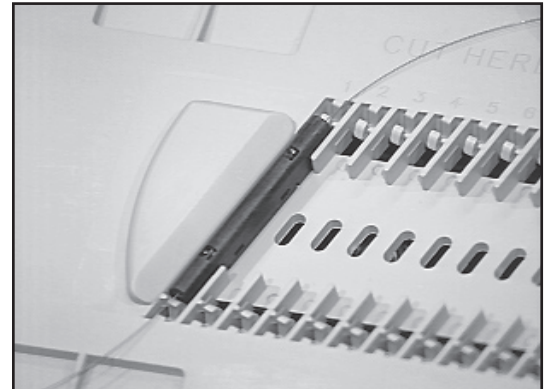

5.06 For remaining fibers, repeat steps 5.01 through 5.05. Fill pockets in order.

5.07 Install and close tray cover making sure that all fibers are properly stored under the tray tabs.

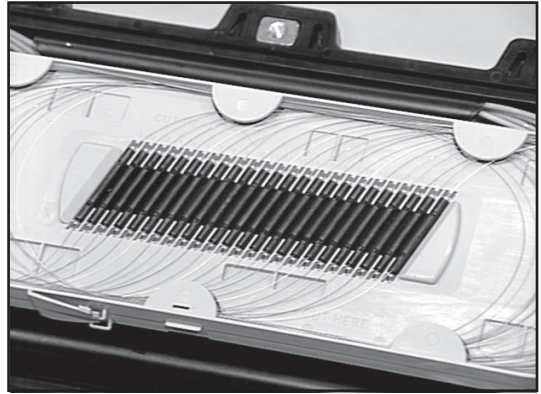

5.08 Snap tray cover shut.

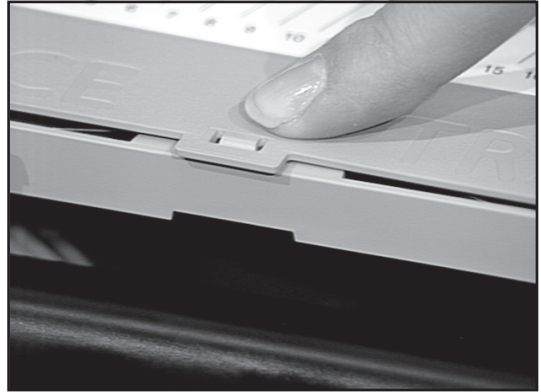

6.0 Install Additional Trays

6.01 Slide the post of the tray being added into the hole in the lever arm on the previously installed tray. (Back view shown).

6.02 Now slide the tray laterally (flexing the lever arm outward) enough to allow the post to be inserted into the opposite lever arm hole. (Back view shown).

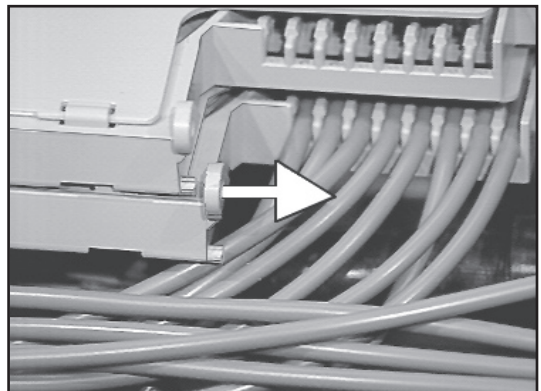
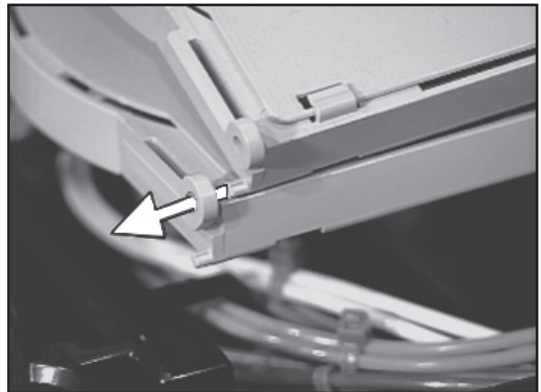

6.03 Lift the tray being added upwards approximately 1/2" (13 mm). Push in on the front snap of the installed tray and lower new tray down and over the snap.

6.04 For additional trays, repeat steps 6.01 through 6.03.

6.05 If trays are used in an aerial application, a wrap of vinyl tape around entire stack between the front snaps and the cover snaps is recommended. This allows for reinforcement before sealing closure.

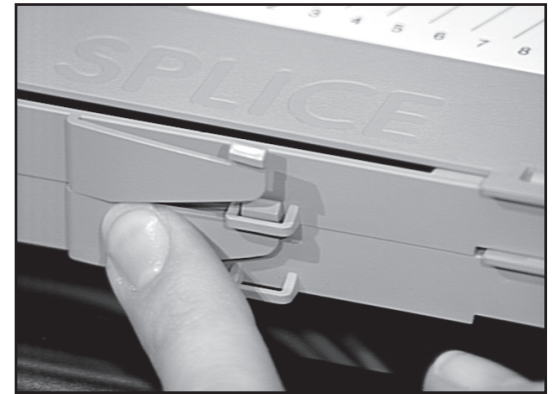

7.0 Tray Identification

7.01 The label on the top of the tray cover allows for the identification of splices and/or fiber count. For ease of use, remove the cover when writing as described in Section 4.01.



3M, Dual-Lok, and Fibrok are trademarks of 3M Company.
All other trademarks used herein are the properties of their respective owners.

Important Notice

All statements, technical information, and recommendations related to 3M's products are based on information believed to be reliable, but the accuracy or completeness is not guaranteed. Before using this product, you must evaluate it and determine if it is suitable for your intended application. You assume all risks and liability associated with such use. Any statements related to the product which are not contained in 3M's current publications, or any contrary statements contained on your purchase order shall have no force or effect unless expressly agreed upon, in writing, by an authorized officer of 3M.

Warranty; Limited Remedy; Limited Liability.

This product will be free from defects in material and manufacture for a period of one (1) year from the time of purchase. **3M MAKES NO OTHER WARRANTIES INCLUDING, BUT NOT LIMITED TO, ANY IMPLIED WARRANTY OF MERCHANTABILITY OR FITNESS FOR A PARTICULAR PURPOSE.** If this product is defective within the warranty period stated above, your exclusive remedy shall be, at 3M's option, to replace or repair the 3M product or refund the purchase price of the 3M product. **Except where prohibited by law, 3M will not be liable for any indirect, special, incidental or consequential loss or damage arising from this 3M product, regardless of the legal theory asserted.**



**Communication Markets Division
3M Telecommunications**

6801 River Place Blvd.
Austin, TX 78726-9000
800.426.8688
Fax 800.626.0329
www.3MTelecommunications.com



*Recycled paper
40% Pre-consumer waste paper
10% Post-consumer waste paper*

Litho in USA
© 3M 2005 78-8135-5475-1-A