



Chipsmall Limited consists of a professional team with an average of over 10 year of expertise in the distribution of electronic components. Based in Hongkong, we have already established firm and mutual-benefit business relationships with customers from,Europe,America and south Asia,supplying obsolete and hard-to-find components to meet their specific needs.

With the principle of “Quality Parts,Customers Priority,Honest Operation,and Considerate Service”,our business mainly focus on the distribution of electronic components. Line cards we deal with include Microchip,ALPS,ROHM,Xilinx,Pulse,ON,Everlight and Freescale. Main products comprise IC,Modules,Potentiometer,IC Socket,Relay,Connector.Our parts cover such applications as commercial,industrial, and automotives areas.

We are looking forward to setting up business relationship with you and hope to provide you with the best service and solution. Let us make a better world for our industry!



Contact us

Tel: +86-755-8981 8866 Fax: +86-755-8427 6832

Email & Skype: info@chipsmall.com Web: www.chipsmall.com

Address: A1208, Overseas Decoration Building, #122 Zhenhua RD., Futian, Shenzhen, China



CHEMINAX

125 OHM, AWG 24, 19 STRANDS OF AWG 36,
RADIO FREQUENCY, TWIN CONDUCTOR CABLE

Date: 03-24-04
Revision: D

THIS SPECIFICATION SHEET FORMS A PART OF THE LATEST ISSUE OF RAYCHEM SPECIFICATION 1200.

Page 1 of 2
Page 2 is for Internal use only.

CONSTRUCTION DETAILS

ELECTRICAL CHARACTERISTICS

DIMENSIONS ARE NOMINAL VALUES IN INCHES UNLESS OTHERWISE DESIGNATED.

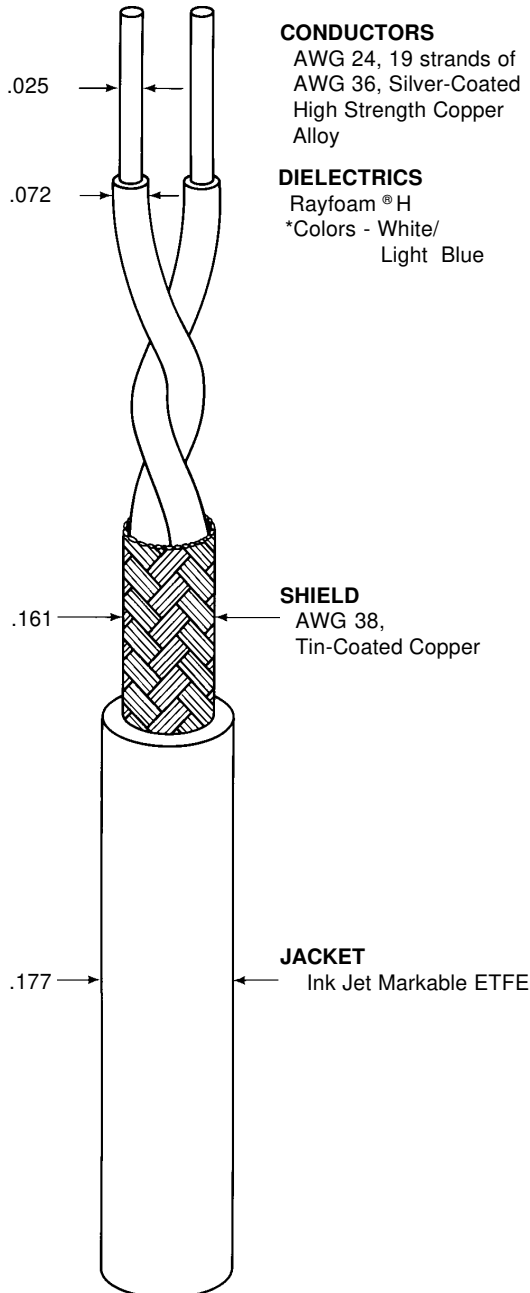

CONDUCTORS
AWG 24, 19 strands of
AWG 36, Silver-Coated
High Strength Copper
Alloy

DIELECTRICS
Rayfoam® H
*Colors - White/
Light Blue

SHIELD
AWG 38,
Tin-Coated Copper

JACKET
Ink Jet Markable ETFE

CHARACTERISTIC	IMPEDANCE	125 ± 10 ohms, Method C at 1 MHz
	CAPACITANCE - MUTUAL	12.0 pF/ft. (nominal)
	VELOCITY OF PROPAGATION	77% (nominal)

ADDITIONAL REQUIREMENTS

ELECTRICAL

CONDUCTOR RESISTANCE	26.5 ohms/1000 ft. (nominal)
INSULATION RESISTANCE	10,000 megohms (minimum) for 1000 ft.
JACKET FLAWS	
SPARK TEST	1.0 kV (rms), 60 Hz
IMPULSE TEST	6.0 kV (peak)
VOLTAGE WITHSTAND (DIELECTRIC)	1000 volts (rms) (minimum)

ENVIRONMENTAL

AGING STABILITY	135°C/-55°C/5.00 inch mandrel
FLAMMABILITY	Method B
LOW TEMPERATURE- COLD BEND	-55°C/5.00 inch mandrel
VOLTAGE WITHSTAND (POST ENVIRONMENTAL)	1000 volts (rms), 1 minute

PHYSICAL

INSULATION (DIELECTRIC) (Prior to Cabling)	
ELONGATION	50% (minimum)
TENSILE STRENGTH	600 lbf/in ² (minimum)
JACKET	
ELONGATION	150% (minimum)
TENSILE STRENGTH	5000 lbf/in ² (minimum)
JACKET THICKNESS	.008 inch (nominal)
SHIELD COVERAGE	90% (minimum)

WEIGHT	19.0 lbs/1000 ft. (nominal)
--------	-----------------------------

Outer jacket color will be white (designated by a "-9" appended to the part number, e.g. 2524E0524-9) unless otherwise specified.
*Options available with approval from Product Management.
Designate outer jacket color with a dash number in accordance with MIL-STD-681. Other codes and suffixes may be added to the part number, as necessary, to capture any additional requirements imposed by the purchase order.

Users should evaluate the suitability of this product for their application. Specifications are subject to change without notice.

Tyco Electronics also reserves the right to make changes in materials or processing, which do not affect compliance with any specification, without notification to Buyer.