



Chipsmall Limited consists of a professional team with an average of over 10 year of expertise in the distribution of electronic components. Based in Hongkong, we have already established firm and mutual-benefit business relationships with customers from,Europe,America and south Asia,supplying obsolete and hard-to-find components to meet their specific needs.

With the principle of "Quality Parts,Customers Priority,Honest Operation,and Considerate Service",our business mainly focus on the distribution of electronic components. Line cards we deal with include Microchip,ALPS,ROHM,Xilinx,Pulse,ON,Everlight and Freescale. Main products comprise IC,Modules,Potentiometer,IC Socket,Relay,Connector.Our parts cover such applications as commercial,industrial, and automotives areas.

We are looking forward to setting up business relationship with you and hope to provide you with the best service and solution. Let us make a better world for our industry!



Contact us

Tel: +86-755-8981 8866 Fax: +86-755-8427 6832

Email & Skype: info@chipsmall.com Web: www.chipsmall.com

Address: A1208, Overseas Decoration Building, #122 Zhenhua RD., Futian, Shenzhen, China



Compact Low-Cost Radio Module

169 MHz Band

Key Features

- Low-cost OEM radio module for the 169 MHz SRD band
- Supporting wireless M-BUS N-Modes (N1a to N1f, N2a to N2g*)
- Compact dimensions: 17 x 27 x 4 mm
- Supports low-power applications and WOR (wake-on radio)
- Integrated wireless M-BUS stack with extensive functions
- Complies with requirements of EN13757-4
- Tape & Reel packaging for automatic component placement
- Pin-Compatible to AMB8426-M¹ & AMB8626-M



Description

The Wireless M-Bus standard (EN13757-4) specifies the communication between water, gas, heat and electricity meters and concentrators. The standard comprises various operating modes (S, T, R and N) to meet the requirements of one-way and two-way data communication in stationary and mobile systems.

The AMB3626-M is an all embedded low-cost wireless M-Bus radio module, which operates in the 169 MHz frequency band (supporting Modes N1a to N1f and N2a to N2g*). The integrated protocol controls the entire data communication. Data packets are built and transmitted according to EN13757-4 specification. Configuration of parameters is handled via the UART interface. The module automatically adds the Manufacturer ID and the Address based on parameters configured in the radio module. Measured field strength (RSSI value) offers the option of enhancing quality of the radio link. (*N2g on request)

The customised application layer can be fully integrated in the radio module, thus eliminating the need for an external host microcontroller. The radio module supports the AES-128 encryption standard. A very low-power mode ensures long battery lifetime.

The graphical user interface of the freely available Windows application "AMBER-ACC" makes it easy to set operating parameters. A USB stick version is available to easily connect the AMB3626-M to a PC system.

The module is pre-certified for operation under the European radio regulations for license-free use.

The AMB3626-M is a surface-mounted module and is available on Tape & Reel for volume production.

Interfaces

The AMB3626-M is connected to a host system via the UART interface with bit rates of up to 115.2 kbaud. Other pins are used for data flow control and to switch between operating modes.

An SPI can be implemented upon request (separate firmware).

Using appropriate firmware, the module is also suitable for autonomously recording digital or analogue signals.

Range of Application

The radio module is designed for automatic meter reading applications for wireless data transmission according to the Wireless M-Bus specification (EN13757-4). The radio module is designed to be integrated in meters, concentrators and mobile metering devices. Other applications are conceivable. Its compact dimensions and low-power consumption make the radio module ideal for battery-powered devices.

¹ Variation in programming Pins.

Dimensions

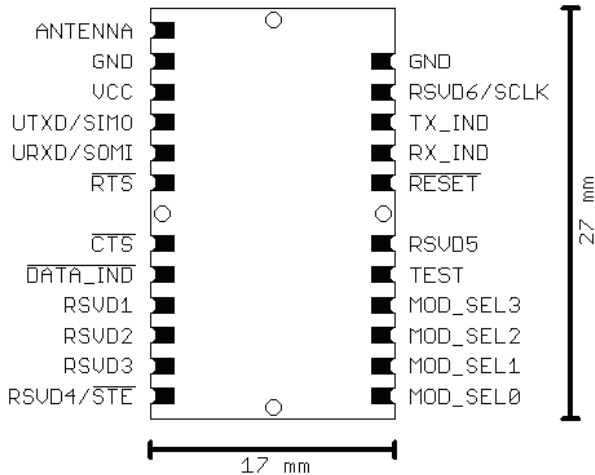

Pin Assignment

Pad Name	Description
ANTENNA	Antenna port
GND	Ground
VCC	Positive supply voltage
UTXD, URXD	UART transmit, UART receive
SIMO	Slave In Master Out (SPI in preparation)
SOMI	Slave Out Master In (SPI in preparation)
SCLK	SPI clock (SPI in preparation)
/STE	Slave Transmit Enable (SPI in preparation)
/RESET	Reset signal
TX_IND	Signals radio transmission
RX_IND	Signals radio reception
MOD_SELx	wM-Bus mode preselect
/RTS, /CTS	Hardware flowcontrol
/DATA_IND	Signals incoming data
RSVDx	Reserved for future use
TEST	Used for programming purposes

Specifications

Performance	Range*	Up to 5000 m
	RF data rate	2.4 / 4.8 / 19.2 kbps (according to EN 13757-4)
	Interface data rate	Up to 115.2 kbps (UART)
	Output power	15 dBm
	RF sensitivity	Down to -120 dBm (@ 50 Ω)
General	Power supply	2.0 – 3.6 V
	Power consumption	- TX: typ. 59 mA - RX: typ. 28 mA - Low Power: typ. <10 µA
	Dimensions	17 x 27 x 4 mm
	Operating temperature	-40 to +85 °C
	Weight	approx. 3 g
	Antenna	External antenna pad (50 Ω)
	Microprocessor	Texas Instruments MSP430
RF technology	Frequency range	169,406 – 169,468 MHz
	Channel spacing	12.5 kHz, 25kHz, 50kHz (according to EN 13757-4)
	Modulation	2-(G)FSK, (G)MSK, 4-(G)FSK
Conformity	Europe	EN 300 220, EN 301 489, EN 60950, EN 50371

* Range stated assumes line-of-sight. Actual range may vary depending on antenna choice, board integration and environment.

Related Products

- AMB8626-M
- AMB8426-M

Ordering information

Item no.	Description
AMB3626-M	Radio Module 169 MHz
AMB3626-M-TR	Radio Module 169 MHz, Tape & Reel



AMBER wireless GmbH
 Phone +49.651.993.550
 Email info@amber-wireless.de
 Internet www.amber-wireless.de