



Chipsmall Limited consists of a professional team with an average of over 10 year of expertise in the distribution of electronic components. Based in Hongkong, we have already established firm and mutual-benefit business relationships with customers from,Europe,America and south Asia,supplying obsolete and hard-to-find components to meet their specific needs.

With the principle of “Quality Parts,Customers Priority,Honest Operation,and Considerate Service”,our business mainly focus on the distribution of electronic components. Line cards we deal with include Microchip,ALPS,ROHM,Xilinx,Pulse,ON,Everlight and Freescale. Main products comprise IC,Modules,Potentiometer,IC Socket,Relay,Connector.Our parts cover such applications as commercial,industrial, and automotives areas.

We are looking forward to setting up business relationship with you and hope to provide you with the best service and solution. Let us make a better world for our industry!



## Contact us

Tel: +86-755-8981 8866 Fax: +86-755-8427 6832

Email & Skype: info@chipsmall.com Web: www.chipsmall.com

Address: A1208, Overseas Decoration Building, #122 Zhenhua RD., Futian, Shenzhen, China



## AMB8626-M

### FEATURES

- Wireless M-Bus EN13757-4:2013
- Easy switching between operating modes S, T and C
- Small form factor: 17 x 27 x 4 mm
- Optimized for battery use

### ABOUT WIRELESS M-BUS

The European standard (EN 13757-4) specifies the communication between water, gas, heat or electricity meters and data loggers, concentrators or smart meter gateways. The standard is widely accepted in Europe as a basis for new Advanced Metering Infrastructure (AMI).

### RANGE OF APPLICATION

The radio module is designed for automatic meter reading applications for wireless data transmission according to the Wireless M-Bus standard. The radio module is designed to be integrated in meters, concentrators and mobile metering devices. Other applications are conceivable. Its compact dimensions and low-power consumption make the radio module ideal for battery-powered devices.

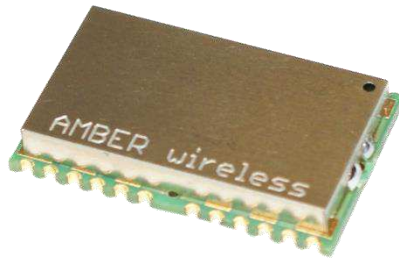

- 868 MHz SRD Band
- UART Interface
- Encryption AES128
- Available on Tape & Reel for SMT assembly
- USB variant available (AMB8665-M)
- Compatible to AMB8426-M, enhanced radio chipset radio and microprocessor
- Low cost
- High Performance
- Conforms with EU RED 2014/53/EU

The wireless M-Bus standard EN13757-4:2013 specifies the communication between water, gas, heat and electricity meters and concentrators. The standard comprises various operating modes (S, T and C) to meet the requirements of one-way and two-way data communication in stationary and mobile systems.

The AMB8626-M is an all embedded low-cost wireless M-Bus radio module operating in the 868 MHz frequency band. The integrated protocol controls the entire data communication. Data packets are built and transmitted according to wireless M-Bus standard. Configuration of parameters is handled via the UART interface. The module automatically adds the Manufacturer ID and the Address based on parameters configured in the radio module. Measured field strength (RSSI value) offers the option of enhancing quality of the radio link.

The customised application layer can be fully integrated in the radio module, thus eliminating the need for an external

host microcontroller. The radio module supports the AES-128 encryption standard Mode 4 + 5. The CMAC authentication code, Mode 7, is available upon request. A very low-power mode ensures long battery lifetime.

The module is pre-certified for operation under the European radio regulations for license-free use.

The AMB8626-M is a surface-mount device and is available on Tape & Reel for volume production.

The AMB8626-M is connected to a host system via an UART interface with data rates of up to 115.2 kbps. Alternatively, an SPI interface can be implemented upon request (separate firmware).

When using appropriate firmware, the module is also suitable for autonomously recording digital or analogue signals. Other pins can be used for data flow control and to switch between operating modes.

## Specifications

TA = 25°C, VCC = 3.3 V if nothing else stated.

Performance	Range*	Up to 1000m
	RF data rate	16.384 / 50 / 66.6 / 100 kcps
	UART data rate	Up to 115.2 kbps
	Output power	Up to +14 dBm @ 50 Ohm
	RF sensitivity	Down to -109 dBm (S) / -101 dBm (C/T) @ 50 Ohm
General	Power supply	2 - 3.6 V
	Power consumption	Tx: typ. 53 mA @ 14dB
		RX: typ. 30 mA
	Low Power: typ. 3 µA	
	Dimensions	17 x 27 x 4 mm
Operating temperature	-30 to +85 °C	
RF	Weight	Approx. 3 g
	Antenna	External antenna port ( 50 Ω
	Frequency	868.3 MHz / 868.95 MHz / 869.525
Compliance	Europe	EN 60950, EN 301 489, EN 62479, EN 300 220

### ABOUT AMBER WIRELESS

AMBER wireless GmbH, established in 1997, is a German electronics company. AMBER specializes in the design and manufacturing of wireless connectivity solutions including compact short range RF modules for rapid implementation of cable-free data links. We have become one of the leading suppliers for low power ISM/SRD products in Europe. AMBER provides high-quality and cost-effective wireless modules and devices as well as custom design services.

### SERVICES AVAILABLE

- Technical Support
- Custom Design Services
- Software / App Development
- Hardware Support

For more information on any of our products or services please visit our website:

[www.amber-wireless.com](http://www.amber-wireless.com)

The Bluetooth® word mark and logos are registered trademarks owned by Bluetooth SIG,

Inc. and any use of such marks by AMBER wireless GmbH is under license. Other trademarks and trade names are those of their respective owners.

## Dimensions and Pin Assignment

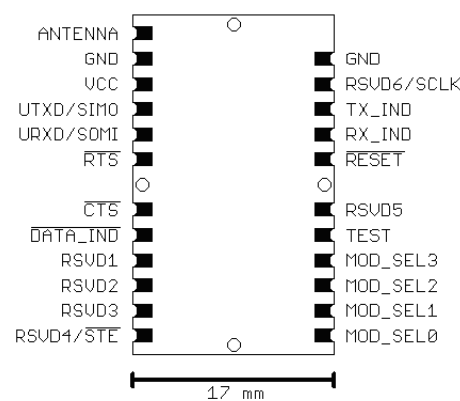

Pad Name	Description
ANTENNA	Antenna port
GND	Ground
VCC	Positive supply voltage
UTXD, URXD	UART transmit, UART receive
SIMO	Slave In Master Out (SPI in preparation)
SOMI	Slave Out Master In (SPI in preparation)
SCLK	SPI clock (SPI in preparation)
/STE	Slave Transmit Enable (SPI in preparation)
/RESET	Reset signal
TX_IND	Signals radio transmission
RX_IND	Signals radio reception
MOD_SELx	wM-Bus mode preselect
/RTS, /CTS	Hardware handshake
/DATA_IND	Signals incoming data
RSVDx	Reserved for future use
TEST	Used for programming purposes

## Ordering Information

Item No.	Description
AMB8626-M	Radio Module 868 MHz
AMB8626-M-TR	Radio Module 868 MHz



Phone +49.651.993.550  
 E-Mail [info@amber-wireless.de](mailto:info@amber-wireless.de)  
 Internet [www.amber-wireless.com](http://www.amber-wireless.com)