



Chipsmall Limited consists of a professional team with an average of over 10 year of expertise in the distribution of electronic components. Based in Hongkong, we have already established firm and mutual-benefit business relationships with customers from,Europe,America and south Asia,supplying obsolete and hard-to-find components to meet their specific needs.

With the principle of "Quality Parts,Customers Priority,Honest Operation,and Considerate Service",our business mainly focus on the distribution of electronic components. Line cards we deal with include Microchip,ALPS,ROHM,Xilinx,Pulse,ON,Everlight and Freescale. Main products comprise IC,Modules,Potentiometer,IC Socket,Relay,Connector.Our parts cover such applications as commercial,industrial, and automotives areas.

We are looking forward to setting up business relationship with you and hope to provide you with the best service and solution. Let us make a better world for our industry!



## Contact us

Tel: +86-755-8981 8866 Fax: +86-755-8427 6832

Email & Skype: info@chipsmall.com Web: www.chipsmall.com

Address: A1208, Overseas Decoration Building, #122 Zhenhua RD., Futian, Shenzhen, China



# AXL F DO32/1 1F

**Axioline F digital output module, 32 outputs,  
24 V DC, 500 mA, 1-wire connection method**



Data sheet  
8124\_en\_01

© PHOENIX CONTACT 2015-05-27

## 1 Description

The module is designed for use within an Axioline F station.

It is used to output digital signals.

The outputs are short-circuit and overload-protected .

### Features

- 32 digital outputs
- 24 V DC, 500 mA
- Connection of actuators in 1-wire technology
- Device type label stored
- Diagnostic and status indicators



This data sheet is only valid in association with the UM EN AXL F SYS INST user manual.



Make sure you always use the latest documentation.  
It can be downloaded from the product at [phoenixcontact.net/products](http://phoenixcontact.net/products).

---

<b>2</b>	<b>Table of contents</b>	
1	Description .....	1
2	Table of contents .....	2
3	Ordering data .....	3
4	Technical data .....	4
5	Maximum outputs power consumption when inductive loads are switched off .....	7
6	Internal circuit diagram .....	7
7	Terminal point assignment.....	8
8	Connection example.....	8
9	Local status and diagnostic indicators .....	9
10	Process data.....	10
11	Parameter, diagnostics and information (PDI) .....	10
12	Standard objects .....	11
	12.1 Objects for identification (device rating plate).....	11
	12.2 Object for multilingual capacity.....	11
	12.3 Diagnostics objects .....	12
	12.4 Objects for process data management.....	13
13	Application objects .....	14
	13.1 Substitute value behavior (FF8Dhex: PD Output Substitute Configuration) .....	14
	13.2 Message "Actuator supply not present" (FF8Fhex: DiagOut).....	14
14	Device descriptions .....	14

### 3 Ordering data

Description	Type	Order No.	Pcs./Pkt.
Axioline F digital output module, 32 outputs, 24 V DC, 500 mA, single-wire connection method (including bus base module and connectors)	AXL F DO32/1 1F	2688051	1
<b>Accessories</b>			
Axioline F bus base module for housing type F (Replacement item)	AXL F BS F	2688129	5
Axioline F connector set (for e.g., AXL F DO32/1 1F) (Replacement item)	AXL CNS 4L-O/D/UO1/UO2/E1	2700983	1
Zack marker strip for Axioline F (device labeling), in 2 x 20.3 mm pitch, unprinted, 25-section, for individual labeling with B-STIFT 0.8, X-PEN, or CMS-P1-PLOTTER (Marking)	ZB 20,3 AXL UNPRINTED	0829579	25
Zack marker strip, flat, in 10 mm pitch, unprinted, 10-section, for individual labeling with M-PEN 0,8, X-PEN, or CMS-P1-PLOTTER (Marking)	ZBF 10/5,8 AXL UNPRINTED	0829580	50
Insert label, Roll, white, unlabeled, can be labeled with: THERMOMARK ROLL, THERMOMARK ROLL X1, THERMOMARK X, THERMOMARK S1.1, Mounting type: snapped into marker carrier, Lettering field: 35 x 46 mm (Marking)	EMT (35X46)R	0801604	1
V8-OUTPUT adapter for eight 6.2 mm PLC interfaces (1 PDT, etc./see "Supplementary Products"). 14-pos. flat-ribbon cable connection for the PLC system cabling, control logic: Plus switching (Connector/Adapter)	PLC-V8/FLK14/OUT	2295554	1
V8L-OUTPUT adapter for eight 14 mm PLC Interfaces (2 PDTs, etc./see "Supplementary Products"). 14-pos. flat-ribbon cable connection for the PLC system cabling, control logic: Plus switching (Connector/Adapter)	PLC-V8L/FLK14/OUT	2299660	1
VARIOFACE module, with screw connection and flat-ribbon cable connector, for mounting on NS 35 rails, with pin strip and short and long locking latches for socket strips, 20-pos.	VIP-2/SC/FLK20	2315049	1
VARIOFACE module, with screw connection and flat-ribbon cable connector, for mounting on NS 35 rails, with pin strip and short and long locking latches for socket strips, 20-pos., with LED	VIP-2/SC/FLK20/LED	2322074	1
VARIOFACE module, with push-in connections and flat-ribbon cable connector, for mounting on NS 35 rails, with pin strip and short and long locking latches for socket strips, 20-pos.	VIP-2/PT/FLK20	2903790	1
VARIOFACE module, with push-in connection and flat-ribbon cable connector, for mounting on NS 35 rails, with pin strip and short and long locking latches for socket strips, 20-pos., with LED	VIP-2/PT/FLK20/LED	2904251	1
VARIOFACE SLIM LINE, with screw connection and flat-ribbon cable connector, for assembly at a right angle on NS 35/7.5, 20 positions	UM 25-FLK20/FRONT/Q	2959515	1
<b>Documentation</b>			
User manual, English, Axioline F: System and installation	UM EN AXL F SYS INST	-	-
User manual, English, Axioline F: Diagnostic registers, and error messages	UM EN AXL F SYS DIAG	-	-

## 4 Technical data

### Dimensions (nominal sizes in mm)

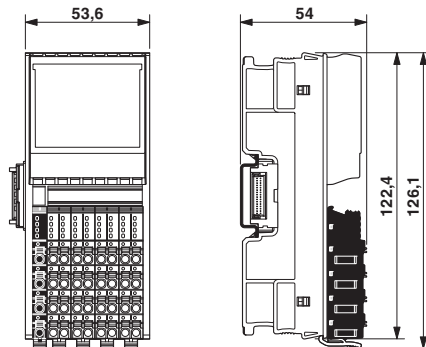

Width	53.6 mm
Height	126.1 mm
Depth	54 mm
Note on dimensions	The depth is valid when a TH 35-7.5 DIN rail is used (according to EN 60715).

### General data

Color	traffic grey A RAL 7042
Weight	191 g (with connectors and bus base module)
Ambient temperature (operation)	-25 °C ... 60 °C
Ambient temperature (storage/transport)	-40 °C ... 85 °C
Permissible humidity (operation)	5 % ... 95 % (non-condensing)
Permissible humidity (storage/transport)	5 % ... 95 % (non-condensing)
Air pressure (operation)	70 kPa ... 106 kPa (up to 3000 m above sea level)
Air pressure (storage/transport)	70 kPa ... 106 kPa (up to 3000 m above sea level)
Degree of protection	IP20
Protection class	III, IEC 61140, EN 61140, VDE 0140-1
Mounting position	Any (no temperature derating)

### Connection data

Designation	Axoline F connector
Connection method	Push-in connection
Conductor cross section solid / stranded	0.2 mm <sup>2</sup> ... 1.5 mm <sup>2</sup> / 0.2 mm <sup>2</sup> ... 1.5 mm <sup>2</sup>
Conductor cross section [AWG]	24 ... 16
Stripping length	8 mm



Please observe the information provided on conductor cross sections in the "Axoline F: system and installation" user manual.

### Interface Axoline F local bus

Connection method	Bus base module
Transmission speed	100 MBit/s

### Communications power

Communications power $U_{BUS}$	5 V DC (via bus base module)
Current consumption from $U_{BUS}$	max. 120 mA
Power consumption at $U_{BUS}$	max. 600 mW

### I/O supply

Supply of digital output modules $U_O$	24 V DC
Maximum permissible voltage range	19.2 V DC ... 30 V DC (including all tolerances, including ripple)
Current consumption from $U_O$	max. 8 A (external fuse)
Power consumption at $U_O$	typ. 800 mW (without actuators), max. 240 W (of which 1.5 W internal losses)
Surge protection of the supply voltage	Electronic (35 V, 0.5 s)
Polarity reversal protection of the supply voltage	Parallel diode; with external 5 A fuse (for startup only)
Protection	max. 8 A (polarity reversal protection up to 5 A)



When using for the first time, protect the module with a 5 A fuse. If all the modules are correctly connected in the system, the 5 A fuse can be replaced by an 8 A fuse. you can now load the module up to 8 A.  
Loads over 8 A are not permitted.



**NOTE: Damage to the electronics**

Provide the module with an external fuse to protect it against polarity reversal. The power supply unit must be able to supply four times the nominal current of the external fuse, to ensure that it trips in the event of an error.

### Digital outputs

Number of outputs	32
Connection method	Push-in connection
Connection method	1-wire
Nominal output voltage	24 V DC
Maximum output current per channel	500 mA
Maximum output current per device	8 A (external fuse)
Nominal load, ohmic	max. 12 W (48 $\Omega$ ; with nominal voltage)
Nominal load, inductive	max. 12 VA (1.2 H; 48 $\Omega$ ; with nominal voltage)
Nominal load, lamp	max. 12 W (at nominal voltage)
Signal delay	max. 150 $\mu$ s (when switched on) max. 200 $\mu$ s (during switching off with ohmic nominal load)
Switching frequency	max. 5500 per second (with ohmic load)
Switching frequency	max. 1 per second (with inductive load)
Switching frequency	max. 16 per second (with nominal lamp load)
Load min.	10 k $\Omega$
Energy consumption	see diagram
Limitation of the voltage induced on circuit interruption	-32.8 V ... -15 V
Output voltage when switched off	max. 1 V
Output current when switched off	max. 300 $\mu$ A
Behavior with overload	Shutdown with automatic restart
Behavior with inductive overload	Output can be destroyed
Reverse voltage resistance to short pulses	Limited protection up to 0.5 A for 1 s



**NOTE: Damage to the electronics**

If there is a faulty external voltage (reverse voltage) at one of the outputs, the output may be destroyed. This may cause unintentional setting of further outputs.

Overcurrent shut-down	as of 0.7 A
Output current with ground connection interrupt when switched off	< 1 mA
Short-circuit protection, overload protection of the outputs	Electronic

**Configuration and parameter data in a PROFIBUS system**

Required parameter data	1 Byte
Need for configuration data	6 Byte

**Error messages to the higher level control or computer system**

Short-circuit / overload of the digital outputs	Yes
---	-----

**Electrical isolation/isolation of the voltage areas**

Test section	Test voltage
5 V communications power (logic), 24 V supply (I/O)	500 V AC, 50 Hz, 1 min
5 V supply (logic)/functional earth ground	500 V AC, 50 Hz, 1 min
24 V supply (I/O) / functional earth ground	500 V AC, 50 Hz, 1 min

**Mechanical tests**

Vibration resistance in acc. with EN 60068-2-6/IEC 60068-2-6	5g
Shock in acc. with EN 60068-2-27/IEC 60068-2-27	30g
Continuous shock according to EN 60068-2-27/IEC 60068-2-27	10g

**Conformance with EMC Directive 2004/108/EC****Noise immunity test in accordance with EN 61000-6-2**

Electrostatic discharge (ESD) EN 61000-4-2/IEC 61000-4-2	Criterion B; 6 kV contact discharge, 8 kV air discharge
Electromagnetic fields EN 61000-4-3/IEC 61000-4-3	Criterion A; Field intensity: 10 V/m
Fast transients (burst) EN 61000-4-4/IEC 61000-4-4	Criterion B, 2 kV
Transient surge voltage (surge) EN 61000-4-5/IEC 61000-4-5	Criterion B; DC supply lines: $\pm 0.5$ kV/ $\pm 0.5$ kV (symmetrical/asymmetrical)
Conducted interference EN 61000-4-6/IEC 61000-4-6	Criterion A; Test voltage 10 V

**Noise emission test according to EN 61000-6-3**

Radio interference properties EN 55022	Class B
--	---------

**Approvals**

For the latest approvals, please visit [phoenixcontact.net/products](http://phoenixcontact.net/products).

## 5 Maximum outputs power consumption when inductive loads are switched off



**NOTE: Damage to the electronics**  
 When you use an external freewheel limit, the free-wheeling voltage to a maximum of -15 V. The value **must** be above -15 V, so -12 V, for example.  
 The external freewheel limit has no function with a higher negative voltage.

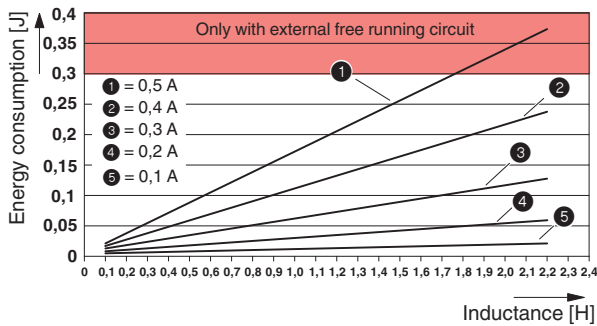

Figure 1 Maximum outputs power consumption when inductive loads are switched off

The specifications in the diagram refer to a maximum switching frequency of 1 Hz.  
 The diagram displays the maximum amount of energy that may be fed back into the the corresponding output groups (outputs 1 to 8, 9 to 16, 17 to 24, 25 to 32) for each switch off procedure during switching off of an inductive load without external freewheeling circuit.  
 The current data refers to the ohmic DC voltage component of the inductive load.

## 6 Internal circuit diagram

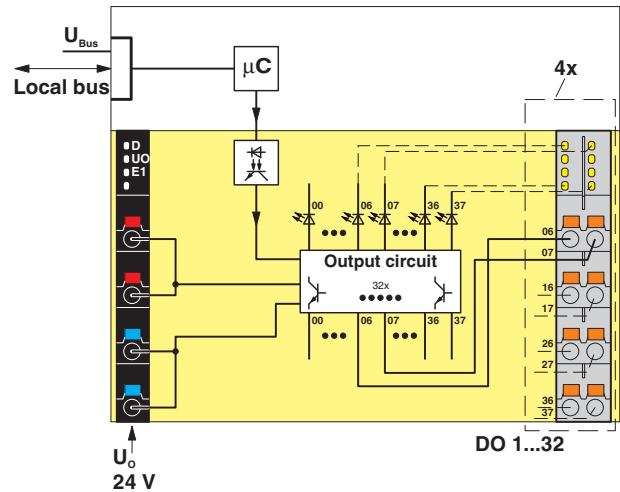

Figure 2 Internal wiring of the terminal points

Key:

Local bus	Axioline F local bus (hereinafter referred to as local bus)
	Microcontroller
	Optocoupler
	LED
	Electrically isolated areas
Output circuit	Output configuration



## 7 Terminal point assignment

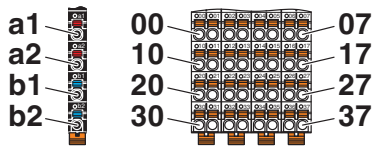

Figure 3 Terminal point assignment

Terminal point	Color	Assignment	
<b>Supply voltage input</b>			
a1, a2	Red	24 V DC (U <sub>O</sub> )	Supply to digital output modules (internally jumpered)
b1, b2	Blue	GND	Reference potential of the supply voltage (internally jumpered)
<b>Digital outputs</b>			
00 ... 07	Orange	OUT1 ... OUT8	Digital outputs 1 ... 8
10 ... 17	Orange	OUT9 ... OUT16	Digital outputs 9 ... 16
20 ... 27	Orange	OUT17 ... OUT24	Digital outputs 17 ... 24
30 ... 37	Orange	OUT25 ... OUT32	Digital outputs 25 ... 32

## 8 Connection example

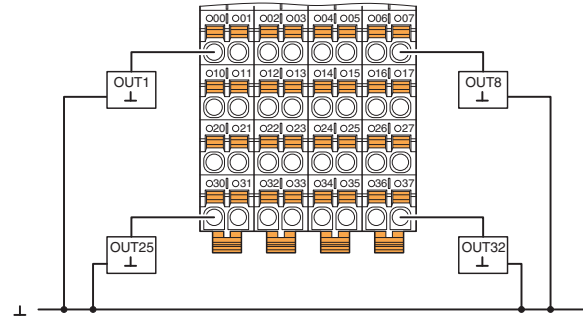

Figure 4 Connection with 1-wire technology

Make sure that the GND of the actuators and the GND for U<sub>O</sub> have the same potential!

## 9 Local status and diagnostic indicators

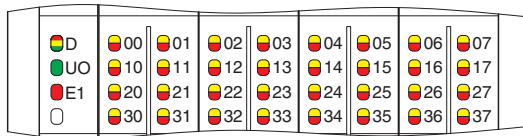

Figure 5 Local status and diagnostic indicators

Designation	Color	Meaning	State	Description
D	Red/ yellow/ green	Diagnostics of local bus communication		
		Run	Green ON	The device is ready for operation, communication within the station is OK. All data is valid. There are no faults.
		Active	Green flashing	The device is ready for operation, communication within the station is OK. The data is <b>not</b> valid. Valid data from the controller/higher-level network not available. There is no fault in the module.
		Device application not active	Flashing green/yellow	The device is ready for operation, communication within the station is OK. Output data <b>cannot</b> be outputted and/or input data <b>cannot</b> be read. There is a fault on the periphery side of the module..
		Ready	Yellow ON	The device is ready for operation but did not detect a valid cycle after power-on.
		Connected	Yellow flashing	The device is not (yet) part of the active configuration.
		Reset	Red ON	The device is ready for operation but has lost the connection to the bus head.
		Not connected	Red flashing	The device is ready for operation but there is no connection to the previously existing device.
		Power down	OFF	Device in (power) reset.
UO	Green	U <sub>Output</sub>	ON	Supply of digital output module present.
			OFF	Supply of digital output modules not present.
E1	Red	Peripheral fault	ON	Breakdown or overload/short-circuit of an output.
			OFF	No I/O error.
00 ... 37	Red/ yellow	Diagnostics / Status of the outputs	Red ON	Short-circuit/overload of the output.
			Yellow ON	Output is set.
			OFF	No error, output is not set.

## 10 Process data

### OUT process data

Byte	0							
Bit	7	6	5	4	3	2	1	0
Channel	8	7	6	5	4	3	2	1
Terminal point	07	06	05	04	03	02	01	00

Byte	1							
Bit	7	6	5	4	3	2	1	0
Channel	16	15	14	13	12	11	10	9
Terminal point	17	16	15	14	13	12	11	10

Byte	2							
Bit	7	6	5	4	3	2	1	0
Channel	24	23	22	21	20	19	18	17
Terminal point	27	26	25	24	23	22	21	20

Byte	3							
Bit	7	6	5	4	3	2	1	0
Channel	32	31	30	29	28	27	26	25
Terminal point	37	36	35	34	33	32	31	30

## 11 Parameter, diagnostics and information (PDI)

Parameter and diagnostic data as well as other information is transmitted via the PDI channel of the AxioLine F station.

The standard and application objects stored in the module are described in the following section.

The following applies to all tables below:

Please refer to the UM EN AXL F SYS INST for an explanation of the object codes and data types.

Abbreviation	Meaning
A	Number of elements
L	Length of the elements in bytes
R	Read
W	Write



Every visible string is terminated with a zero terminator (00<sub>hex</sub>). The length of a visible string element is therefore one byte larger than the amount of user data.



For detailed information on PDI and the objects, please refer to the UM EN AXL F SYS INST user manual.

## 12 Standard objects

### 12.1 Objects for identification (device rating plate)

Index (hex)	Object name	Object type	Data type	A	L	Rights	Meaning	Contents
<b>Manufacturer</b>								
0001	VendorName	Var	Visible String	1	16	R	Vendor name	Phoenix Contact
0002	VendorID	Var	Visible String	1	7	R	Vendor ID	00A045
0003	VendorText	Var	Visible String	1	49	R	Vendor text	Components and systems for industrial automation
0012	VendorURL	Var	Visible String	1	23	R	Vendor URL	www.phoenixcontact.com
<b>Module - general</b>								
0004	DeviceFamily	Var	Visible String	1	16	R	Device family	I/O digital OUT
0006	ProductFamily	Var	Visible String	1	6	R	Product family	AXL F
000E	CommProfile	Var	Visible String	1	4	R	Communication profile	633
000F	DeviceProfile	Var	Visible String	1	5	R	Device profile	0010
0011	ProfileVersion	Record	Visible String	2	11; 20	R	Profile version	2011-12-07; Basic Profile V2.0
003A	VersionCount	Array	Unsigned 16	4	4 * 2	R	Version counter	e.g., 0007 0001 0000 0000 <sub>hex</sub>
<b>Module - special</b>								
0005	Capabilities	Array	Visible String	1	8	R	Features	Nothing
0007	ProductName	Var	Visible String	1	16	R	Product name	AXL F DO32/1 1F
0008	SerialNo	Var	Visible String	1	11	R	Serial number	xxxxxxxx (e. g., 1234512345)
0009	ProductText	Var	Visible String	1	19	R	Product text	32 digital outputs
000A	OrderNumber	Var	Visible String	1	8	R	Order No.	2688051
000B	HardwareVersion	Record	Visible String	2	11; 3	R	Hardware version	e. g., 2011-02-04; 00
000C	FirmwareVersion	Record	Visible String	2	11; 3	R	Firmware version	0000-00-00; --
000D	PChVersion	Record	Visible String	2	11; 6	R	Parameter channel version	2010-01-08; V1.00
0037	DeviceType	Var	Octet string	1	8	R	Module identification	00 40 00 04 00 00 00 D3 <sub>hex</sub>
<b>Use of the device</b>								
0014	Location	Var	Visible String	1	59	R/W	Location	Can be filled out by the user.
0015	EquipmentIdent	Var	Visible String	1	59	R/W	Equipment identifier	Can be filled out by the user.
0016	ApplDeviceAddr	Var	Unsigned 16	1	2	R/W	Application device address	Can be filled out by the user.

### 12.2 Object for multilingual capacity

Index (hex)	Object name	Object type	Data type	A	L	Rights	Meaning	Contents
0017	Language	Record	Visible String	2	6; 8	R	Language	en-us; English

### 12.3 Diagnostics objects

Index (hex)	Object name	Object type	Data type	A	L	Rights	Assignment/content
0018	DiagState	Record		6	2; 1; 1; 2; 1; 1	R	Diagnostic state

#### Diagnostics state (0018<sub>hex</sub>: DiagState)

This object is used for a structured message of an error.

0018 <sub>hex</sub> : DiagState (Read)					
Subindex	Data type	Length in bytes	Meaning	Contents	
0	Record	8	Diagnostic state	Complete diagnostics information	
1	Unsigned 16	2	Error number	0 ... 65535 <sub>dez</sub>	
2	Unsigned 8	1	Priority	00 <sub>hex</sub>	No error
				01 <sub>hex</sub>	Error
				02 <sub>hex</sub>	Warning
				81 <sub>hex</sub>	Error removed
				82 <sub>hex</sub>	Warning eliminated
3	Unsigned 8	1	Channel/group/module	00 <sub>hex</sub>	No error
				FF <sub>hex</sub>	entire device
4	Unsigned 16	2	Error code	See table below	
5	Unsigned 8	1	More follows	00 <sub>hex</sub>	
6	Visible String	1	Text	00 <sub>hex</sub>	



The message with the priority 81<sub>hex</sub> or 82<sub>hex</sub> is a one-time internal message to the bus coupler that is implemented onto the error mechanisms of the higher-level system by the bus coupler.



After all errors have been eliminated, it is automatically reset.

Error and status of the local status and diagnostics indicators

Subindex	2	3	4					
Error	Priority	Channel/ group/ module	Error code		LED			
	hex	hex	hex	dec	D	U <sub>O</sub>	E1	xx
No error	00	00	0000	0	Green ON	ON	OFF	OFF
Short-circuit/overload of an output	02	FF	2344	9028	Green ON	ON	Red ON	Red ON
Actuator supply not present	01	FF	3422	13346	flashing green or green/yellow	OFF	OFF	OFF

xx LED                   Diagnostics of the output  
 xx                        00 ... 07, 10 ... 17, 20 ... 27, 30 ... 37

The behavior of LED D during an "Actuator supply not present" error depends on whether you have switched error reporting via the FF8F<sub>hex</sub> object on or off.

Parameterization in FF8F <sub>hex</sub>	D LED
Do not report error to the controller	green
Report error to the controller	Flashing green/yellow

#### 12.4 Objects for process data management

Index (hex)	Object name	Object type	Data type	A	L	Rights	Assignment
0026	PDOOUT	Var	Octet string	1	4	R	Output process data
003B	PDIN_Descr	Array of Records		3	8; 2; 2	R	Description of the IN process data
003C	PDOOUT_Descr	Array of Records		3	8; 2; 2	R	Description of the output process data

The objects 003B<sub>hex</sub> and 003C<sub>hex</sub> are only applicable to tools.

#### OUT process data (0026<sub>hex</sub>: PDOOUT)

You can read the OUT process data of the module with this object.

The structure corresponds to the representation in the "Process data" section.

0026 <sub>hex</sub> : PDOOUT (Read)			
Subindex	Data type	Length in bytes	Meaning
0	Octet string	4	Output process data

## 13 Application objects

Index (hex)	Object name	Object type	Data type	A	L	Rights	Assignment
FF8D	PD Output Substitute Configuration	Var	Unsigned 8	1	1	R/W	Substitute value behavior
FF8F	DiagOut	Var	Unsigned 8	1	1	R/W	Message "Actuator supply not present"

In the case of valid parameters, the parameterization is stored in the module permanently.

### 13.1 Substitute value behavior (FF8D<sub>hex</sub>: PD Output Substitute Configuration)

With this object, you parameterize the behavior of the module so that an application reset can be detected if necessary.

FF8D <sub>hex</sub> : PD Output Substitute Configuration (Read, write)				
Subindex	Data type	Length in bytes	Contents	
0	Var	1	00 <sub>hex</sub> (Default)	"0" output to all output bits
			01 <sub>hex</sub>	Hold last value

### 13.2 Message "Actuator supply not present" (FF8F<sub>hex</sub>: DiagOut)

With this object, you parameterize whether the "Actuator supply missing" error is reported to the controller or not.

If you parameterize the module so that the error is not reported to the controller, the corresponding indicator in LED D (flashing green/yellow) is suppressed and the LED lights up green.

FF8F <sub>hex</sub> : DiagOut (Read, write)				
Subindex	Data type	Length in bytes	Contents	
0	Var	1	00 <sub>hex</sub> (Default)	Do not report error to the controller
			01 <sub>hex</sub>	Report error to the controller

## 14 Device descriptions

The device is described in the device description files.

The device descriptions for controllers from Phoenix Contact are included in PC Worx and the corresponding service packs.

The device description files for other systems are available for download at [phoenixcontact.net/products](http://phoenixcontact.net/products) in the download area of the bus coupler used.