



Chipsmall Limited consists of a professional team with an average of over 10 year of expertise in the distribution of electronic components. Based in Hongkong, we have already established firm and mutual-benefit business relationships with customers from,Europe,America and south Asia,supplying obsolete and hard-to-find components to meet their specific needs.

With the principle of "Quality Parts,Customers Priority,Honest Operation,and Considerate Service",our business mainly focus on the distribution of electronic components. Line cards we deal with include Microchip,ALPS,ROHM,Xilinx,Pulse,ON,Everlight and Freescale. Main products comprise IC,Modules,Potentiometer,IC Socket,Relay,Connector.Our parts cover such applications as commercial,industrial, and automotives areas.

We are looking forward to setting up business relationship with you and hope to provide you with the best service and solution. Let us make a better world for our industry!



Contact us

Tel: +86-755-8981 8866 Fax: +86-755-8427 6832

Email & Skype: info@chipsmall.com Web: www.chipsmall.com

Address: A1208, Overseas Decoration Building, #122 Zhenhua RD., Futian, Shenzhen, China



PSD-S CE-TM SPRING

Connection element with spring-cage terminal blocks for tube mounting

Data sheet
7958_en_02

© PHOENIX CONTACT 2015-05-04



1 Description

This connection element is provided as a component of a modular signal tower and facilitates the electrical connection of the signal tower.

According to your requirements, a signal tower may comprise any combination of up to five signal elements. You may use up to five optical signal elements or up to four optical and one audible signal element.

An audible signal element can be used as top element only.

A bayonet locking system establishes the mechanical and electrical connection between the elements.

Mounting elements for base or tube mounting can be used to mount the signal tower.

Features

- Connection element for the mounting on a tube (see accessories)
- Spring-cage connection
- Degree of protection: IP65, when mounted



Make sure you always use the latest documentation.
It can be downloaded from the product at phoenixcontact.net/products.

2 Table of contents

1 Description 1

2 Table of contents 2

3 Ordering data 3

4 Technical data 3

5 Mounting the connection element..... 4

6 Connecting the cables 5

7 Example of a signal tower 5

8 Assembly notes for a signal tower 5

3 Ordering data

Description	Type	Order No.	Pcs./Pkt.
Connection element with spring-cage terminal blocks for tube mounting	PSD-S CE-TM SPRING	2700092	1
Accessories	Type	Order No.	Pcs./Pkt.
Adapter for single-hole mounting	PSD-S ME A-SH M18	2700150	1
Foot with integrated tube, 110 mm long, black	PSD-S ME BT 110	2700156	1
Tube, 250 mm long, Ø 25 mm	PSD-S ME T-M 250	2700157	1
Tube, 400 mm long, Ø 25 mm	PSD-S ME T-M 400	2700158	1
Tube, 1000 mm long, Ø 25 mm	PSD-S ME T-M 1000	2700154	1
Foot for tube Ø 25 mm, aluminium, black	PSD-S ME B-M	2700164	1
Foot for tube Ø 25 mm, plastic, black	PSD-S ME B-P	2700163	1
Tube, 45 mm long, Ø 25 mm, for direct tube mounting on the foldaway base	PSD-S ME T-P 45	2700152	1
Foldaway base, pitch 7.5°, black	PSD-S ME FB	2700151	1
Outlet box with lateral cable entry for floor and base mounting	PSD-S ME OB	2700153	1
Outlet box with magnetic base for base mounting, black	PSD-S ME OB/MB	2700155	1
Angle for base mounting, concealed cable routing, black	PSD-S ME BR-BM/HCR	2700149	1
Angle for base mounting, black	PSD-S ME BR-BM	2700143	1

4 Technical data

Dimensions (in mm)

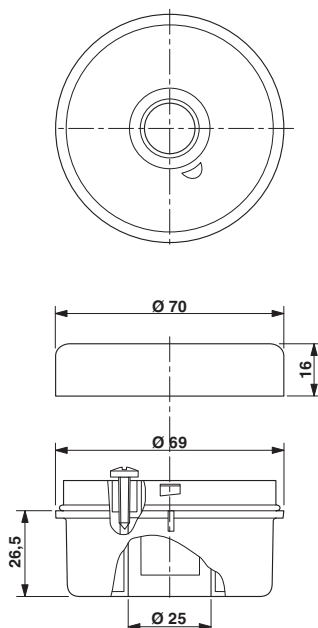

Diameter	69 mm
Height	27 mm

General data

Material	PA-GF
Color	black
Weight	77 g
Ambient temperature (operation)	-30 °C ... 50 °C
Degree of protection	IP65, when installed
Mounting position	any
Mounting type	Tube mounting
Connection	Rubber seal pre-installed for each element
Number of mountable signal elements	max. 5
Scope of delivery	End cover and seal

Connection data (without ferrule)

Connection method	Spring-cage connection
Conductor cross section, stranded	0.5 mm ² ... 1.5 mm ²
Conductor cross section, stranded [AWG]	20 - 15
Stripping length	7 mm

Connection data (With ferrule)

Connection method	Spring-cage connection
Conductor cross section, stranded	0.25 mm ² ... 1.5 mm ²
Conductor cross section, stranded [AWG]	23 - 15
Stripping length	7 mm

Connection data (solid)

Connection method	Spring-cage connection
Conductor cross section, solid	0.5 mm ² ... 1.5 mm ²
Conductor cross section, solid [AWG]	20 - 15
Stripping length	7 mm

Approvals / conformities

Conformance with EMC directive 2004/108/EC and for low-voltage directive 2006/95/EC

For the latest approvals, please visit phoenixcontact.net/products.

5 Mounting the connection element

Mount the connection element on a tube. The possible options are indicated in the ordering data under accessories.

For the mounting the connection element, proceed as described in the package slip.

For the connection of cables, proceed as described in the package slip.



Please refer to the package list for connection options. It is enclosed with the connection element and can be downloaded from the internet at phoenixcontact.net/products.

6 Connecting the cables



NOTE:
When working on the connection element, disconnect the power to the signal tower!

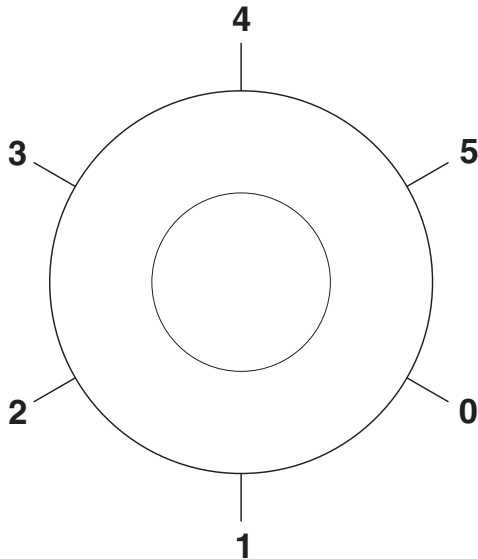

Figure 1 Connections in the connection element

Connection	Meaning
0	Reference potential (GND, N)
1	Control of the signal element 1
2	Control of the signal element 2
3	Control of the signal element 3
4	Control of the signal element 4
5	Control of the signal element 5



When using the audible elements "siren element, 7 tones..." or "voice output element", several control lines are needed for the audible element, as the case may be. In this case, please note the entries in the corresponding data sheet or in the package slip.

7 Example of a signal tower

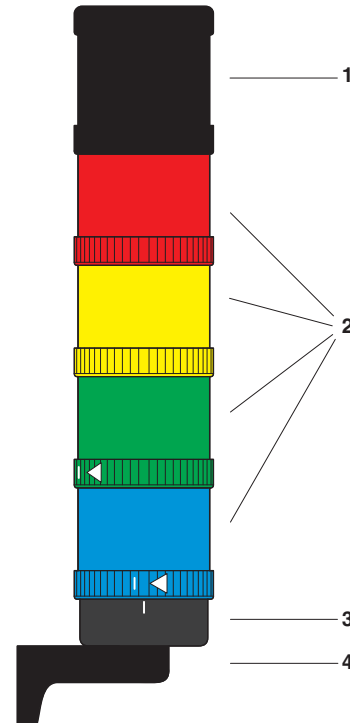

Figure 2 Example of a signal tower

Key:

- 1 Audible signal element
- 2 Optical signal element
- 3 Connection element
- 4 Assembly element

8 Assembly notes for a signal tower

- Only use a maximum of five elements within a signal tower.
- Use only one audible element in a signal tower and position this element on top.
- When connecting the bayonet locking, please note the markings (see "Assembly of the individual elements" in the data sheets of the signal elements).