



Chipsmall Limited consists of a professional team with an average of over 10 year of expertise in the distribution of electronic components. Based in Hongkong, we have already established firm and mutual-benefit business relationships with customers from,Europe,America and south Asia,supplying obsolete and hard-to-find components to meet their specific needs.

With the principle of "Quality Parts,Customers Priority,Honest Operation,and Considerate Service",our business mainly focus on the distribution of electronic components. Line cards we deal with include Microchip,ALPS,ROHM,Xilinx,Pulse,ON,Everlight and Freescale. Main products comprise IC,Modules,Potentiometer,IC Socket,Relay,Connector.Our parts cover such applications as commercial,industrial, and automotives areas.

We are looking forward to setting up business relationship with you and hope to provide you with the best service and solution. Let us make a better world for our industry!



## Contact us

Tel: +86-755-8981 8866 Fax: +86-755-8427 6832

Email & Skype: info@chipsmall.com Web: www.chipsmall.com

Address: A1208, Overseas Decoration Building, #122 Zhenhua RD., Futian, Shenzhen, China



# PSD-S OE LED FL ...

**LED flashing beacon element, 24 V DC, double flash**



## Data sheet

7951\_00

© PHOENIX CONTACT - 04/2009

## 1 Description

This optical signal element is part of a modular signal tower.

According to your requirements, a signal tower may comprise any combination of up to five signal elements. You may use up to five optical signal elements or up to four optical and one audible signal element.

An audible signal element can be used as top element only.

A bayonet locking system establishes the mechanical and electrical connection between the elements.

Connection elements with spring-cage or screw connection can be used for electrical connection of the signal tower.

Mounting elements for base or tube mounting can be used to mount the signal tower.

### Features

- LED flashing beacon element for 24 V DC
- Colors: red, yellow, blue and plain
- Double flash
- Degree of protection: IP65, when installed or with cover



Make sure you always use the latest documentation.

It can be downloaded at <http://www.phoenixcontact.net/download>.



This data sheet is valid for all products listed on the following page:

## Table of contents

Description .....	1
Ordering data .....	2
Technical data .....	2
Example of a signal tower .....	4
Assembly notes for a signal tower .....	4
Assembling the individual elements .....	4
Example for signal tower dimensions .....	5

## 2 Ordering data

Description	Type	Order No.	Pcs. / Pkt.
LED flashing beacon element, 24 V DC, double flash, red	PSD-S OE LED FL RD	2700115	1
LED flashing beacon element, 24 V DC, double flash, yellow	PSD-S OE LED FL YE	2700124	1
LED flashing beacon element, 24 V DC, double flash, clear	PSD-S OE LED FL CL	2700129	1
LED flashing beacon element, 24 V DC, double flash, blue	PSD-S OE LED FL BU	2700134	1

## 3 Technical data

### Dimensions (in mm)

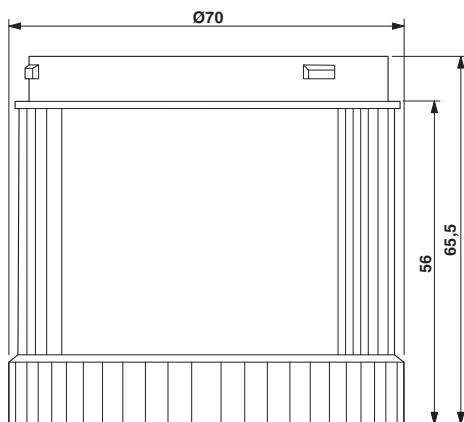

**General data**

Diameter	70.00 mm
Height	65.50 mm
Material	Polycarbonate PC
Calotte color: PSD-S OE LED FL RD	red
Calotte color: PSD-S OE LED FL YE	yellow
Calotte color: PSD-S OE LED FL CL	clear
Calotte color: PSD-S OE LED FL BU	blue
Weight	72 g
Ambient temperature (operation)	-20 °C ... 50 °C
Degree of protection	IP65, when installed or with cover
Mounting position	Any
Connection	Rubber seal pre-installed for each element

**Electrical data**

Input voltage	24 V DC
Inrush current	Max. 200 mA
Current consumption	35 mA
Optical signal type	LED flashing beacon with double flash
Signal frequency	Approx. 1 Hz
Service life, electrical	max. 50,000 h
Operating time	100 %

**Approvals / conformities**

Conformance with EMC directive 2004/108/EC

For the latest approvals, please visit <http://www.phoenixcontact.net/catalog>.



#### 4 Example of a signal tower

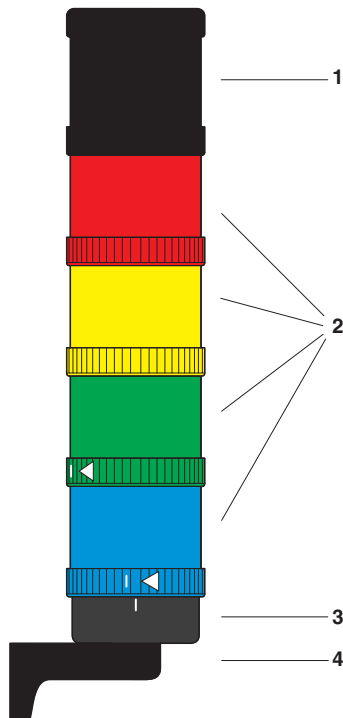

Figure 1 Example of a signal tower

Key:

- 1 Audible signal element
- 2 Optical signal element
- 3 Connection element
- 4 Assembly element

#### 5 Assembly notes for a signal tower

- You may use up to five signal elements in a signal tower.
- Use only one audible element in a signal tower and position this element on top.
- When closing the bayonet locking system, observe the markings (see "Assembling the individual elements").

#### 6 Assembling the individual elements

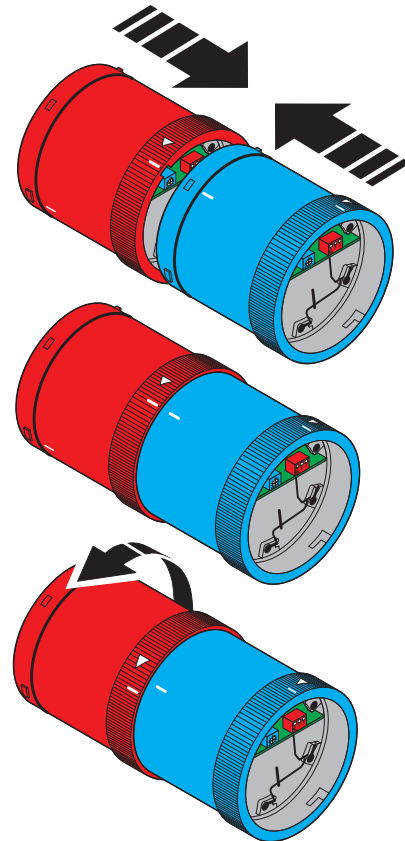

Figure 2 Assembling the individual elements

- Select the elements for your application.
- Connect the elements to be assembled so that the markings are aligned.
- Turn the upper element in the direction of the arrow.

### 7 Example for signal tower dimensions

The following figure shows the dimensions of a typical signal tower.

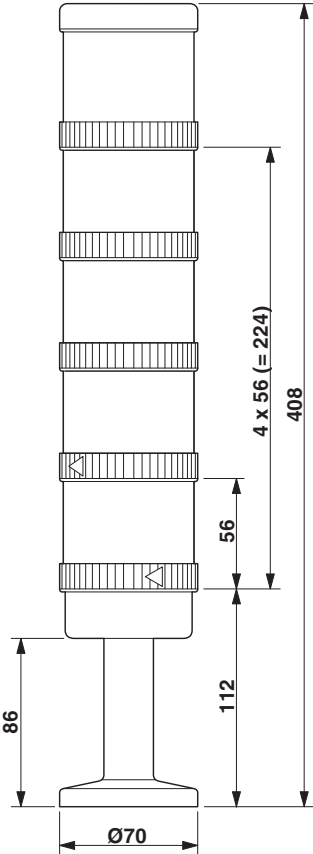

Figure 3 Dimensions of a signal tower (example)