



Chipsmall Limited consists of a professional team with an average of over 10 year of expertise in the distribution of electronic components. Based in Hongkong, we have already established firm and mutual-benefit business relationships with customers from,Europe,America and south Asia,supplying obsolete and hard-to-find components to meet their specific needs.

With the principle of “Quality Parts,Customers Priority,Honest Operation,and Considerate Service”,our business mainly focus on the distribution of electronic components. Line cards we deal with include Microchip,ALPS,ROHM,Xilinx,Pulse,ON,Everlight and Freescale. Main products comprise IC,Modules,Potentiometer,IC Socket,Relay,Connector.Our parts cover such applications as commercial,industrial, and automotives areas.

We are looking forward to setting up business relationship with you and hope to provide you with the best service and solution. Let us make a better world for our industry!



Contact us

Tel: +86-755-8981 8866 Fax: +86-755-8427 6832

Email & Skype: info@chipsmall.com Web: www.chipsmall.com

Address: A1208, Overseas Decoration Building, #122 Zhenhua RD., Futian, Shenzhen, China



PSR-PC40

SIL coupling relay

Data sheet
106256_en_03

© PHOENIX CONTACT 2015-07-14

SIL
IEC 61508



1 Description

Intended Use

The **PSR-PC40** SIL coupling relay can be used for power adaptation and electrical isolation in high and low-demand applications up to SIL 3 according to IEC 61508 as well as EN 61511.

Using this module, circuits are interrupted in a safety-oriented manner.

The safety relay is equipped with two enabling current paths that drop out without delay corresponding to stop category 0 according to EN 60204-1.

By filtering the controller test pulses, premature failure of the safety relays is prevented.

If an error occurs inside the module, the internal device input impedance is affected. As such with compatible, safe systems, the test pulses sent from the controller may be disrupted and the error can be reported back to the corresponding digital output without any additional wiring effort.

The module performs a selftest the moment it is switched on and prevents the enable contacts from being closed in the event of an error.

Features

- SIL 3 coupling relay for safety-related switching off
- Can be used in high and low-demand applications
- Approved for Class I, Zone 2 applications
- Easy proof test:
 - Active error acknowledgment via A1
 - Self-monitoring, with device-internal locking
 - Visually on the device
- Integrated DCS test pulse filter
- Low inrush current
- 2 undelayed enabling current paths
- 1 digital signal output
- Option of screw or spring-cage terminal blocks for plug-in
- 12.5 mm housing width
- Controller-specific Termination Carrier available on request



WARNING: Risk of electric shock

Observe the safety instructions in the corresponding section!



Make sure you always use the latest documentation.
It can be downloaded from the product at phoenixcontact.net/products.



This data sheet is valid for all products listed on the following pages.

2	Table of contents	
1	Description	1
2	Table of contents	2
3	Ordering data	3
4	Technical data	3
5	Safety notes.....	6
	5.1 Installation in the Ex area (class I, zone 2).....	7
	5.2 Installation in areas with a danger of dust explosions	7
6	Basic circuit diagram	8
7	Derating.....	8
	7.1 Vertical mounting position	8
	7.2 Horizontal mounting position	8
	7.3 Mounting position with module front at the top.....	9
8	Load curve.....	9
	8.1 Ohmic load	9
9	Operating and indication elements	10
	9.1 Connection versions.....	10
	9.2 Connection assignment.....	10
10	Mounting and connection	11
11	Startup.....	11
12	Proof test	11
13	Calculating the power dissipation	12
14	Application examples	13
	14.1 Application example 1 - SIL 3.....	13
	14.2 Application example 2 - SIL 3.....	13
15	Revision history	14

3 Ordering data

Description	Type	Order No.	Pcs. / Pkt.
Coupling relay for SIL 3 high- and low-demand applications, couples digital output signals to the I/O, 2 enabling current paths, 1 digital signal output, safe state off applications, test pulse filter, plug-in screw terminal block	PSR-PC40-2NO-1DO-24DC-SC	2700588	1
Coupling relay for SIL 3 high- and low-demand applications, couples digital output signals to the I/O, 2 enabling current paths, 1 digital signal output, safe state off applications, test pulse filter, plug-in spring-cage terminal block	PSR-PC40-2NO-1DO-24DC-SP	2700589	1

4 Technical data

Hardware/firmware version	
HW/FW	≥ 00/-- (The technical data and safety characteristics are valid as of the specified HW/FW version.)
Input data	
Rated control supply voltage U_S	24 V DC -15 % / +10 %
Rated control supply current I_S	typ. 75 mA
Typical inrush current	400 mA ($\Delta t < 100 \mu s$ at U_S) < 10 mA (Y1-Y2)
Current consumption	< 5 mA (Y1-Y2)
Power consumption at U_S	typ. 1.8 W
Voltage at input/start and feedback circuit	24 V DC -15 % / +10 % (Y1-Y2)
Filter time	max. 2 ms (at A1-A2; test pulse width) ≥ 100 ms (at A1-A2; test pulse rate)
Max. permissible overall conductor resistance (Input and reset circuit at U_S)	150 Ω (Y1-Y2)
Typical starting time with U_S	< 200 ms (when controlled via A1; automatic start)
Typical release time with U_S	< 35 ms (when controlled via A1)
Recovery time	500 ms
Maximum switching frequency	0.5 Hz
Operating voltage display	1 x yellow LED
Status display	2 x green LEDs
Indication	1 x red LED
Protective circuit	Surge protection Suppressor diode Reverse polarity protection for rated control supply voltage
Output data	
Contact type	2 enabling current paths
Contact material	AgSnO ₂
Minimum switching voltage	20 V AC/DC
Maximum switching voltage	250 V AC/DC
Nominal current	6 A (see to derating)
Limiting continuous current	6 A (N/O contact)
Maximum inrush current	6 A
Inrush current, minimum	3 mA
Sq. Total current	60 A ² (see to derating)
Switching capacity min.	60 mW
Mechanical service life	10 x 10 ⁶ cycles
Output fuse	6 A gL/gG (N/O contact) 4 A gL/gG (for low-demand applications)

Alarm outputs

Number of outputs	1 (digital, PNP)
Voltage	22 V DC ($U_S - 2 V$)
Current	max. 100 mA
Maximum inrush current	500 mA ($\Delta t = 1 \text{ ms at } U_S$)
Short-circuit protection	no

General data

Relay type	Electromechanically forcibly guided, dust-proof relay.
Nominal operating mode	100% operating factor
Degree of protection	IP20
Min. degree of protection of inst. location	IP54
Mounting type	DIN rail mounting
Mounting position	vertical, horizontal, with front of module upward
Assembly instructions	See derating curve
Type of housing	PBT yellow
Clearances and creepage distances between the power circuits	DIN EN 50178, EN 60079-15
Rated insulation voltage	250 V AC
Rated surge voltage/insulation	Safe isolation, 6 kV reinforced insulation from control circuit, start circuit, signal output to the enabling current paths, 4 kV/basic insulation between the enabling current paths and between all current paths and housing
Pollution degree	2
Surge voltage category	III

Dimensions

	Screw connection	Spring-cage connection
W x H x D	12.5 x 112.2 x 114.5 mm	12.5 x 116.6 x 114.5 mm

Connection data

	Screw connection	Spring-cage connection
Conductor cross section, solid	0.2 mm ² ... 2.5 mm ²	0.2 mm ² ... 1.5 mm ²
Conductor cross section, stranded	0.2 mm ² ... 2.5 mm ²	0.2 mm ² ... 1.5 mm ²
Conductor cross section AWG/kcmil	24 ... 12	24 ... 16
Stripping length	7 mm	8 mm
Screw thread	M3	

Ambient conditions

Ambient temperature (operation)	-40 °C ... 70 °C (observe derating)
Ambient temperature (storage/transport)	-40 °C ... 85 °C
Max. permissible relative humidity (operation)	75 % (on average, 85% infrequently, non-condensing)
Max. permissible humidity (storage/transport)	75 % (on average, 85% infrequently, non-condensing)
Maximum altitude	max. 2000 m (Above sea level)
Shock	15g
Vibration (operation)	2g

Conformance / approvals

Conformance	CE-compliant
Approvals	
UL, USA / Canada (E140324)	cULus
UL, USA / Canada (E360692)	Class I, Zone 2, AEx nA nC IIC T4 / Ex nA nC IIC Gc T4 X
Shipbuilding	GL applied for
Functional Safety in accordance with IEC 61508	to SIL 3

Safety data

Stop category according to IEC 60204 0

Safety parameters for IEC 61508 - High demand

Equipment type	Type A
HFT	1
SIL	3 (< 15% of the overall SIL)
PFH _d	1.04 x 10 ⁻¹⁰ (4 A DC13; 5 A AC15; 8760 switching cycles/year)
Demand rate	< 12 Months
Proof test interval	240 Months
Duration of use	240 Months

Alternative illustration of the device as 1001 structure for process customers

Equipment type	Type A
HFT	0
SIL	3 (< 15% of the overall SIL)
Safe Failure Fraction (SFF)	99.99 %
λSD	989.32 FIT
λSU	397.43 FIT
λDD	51.90 FIT
λDU	0.10 FIT
λTotal	1438.75 FIT
MTBF	64.98 Years
PFH	1.04 x 10 ⁻¹⁰ (4 A DC13; 5 A AC15; 8760 switching cycles/year)

Safety parameters for IEC 61508 - Low demand

Equipment type	Type A
HFT	1
SIL	3 (< 15% of the overall SIL)
PFD _{avg}	1.23 x 10 ⁻⁴
Proof test interval	72 Months
Duration of use	240 Months

Alternative illustration of the device as 1001 structure for process customers

Equipment type	Type A
HFT	0
SIL	3 (< 15% of the overall SIL)
Safe Failure Fraction (SFF)	99.71 %
λSD	0 FIT
λSU	1798 FIT
λDD	0 FIT
λDU	5.236 FIT
λTotal	1803 FIT
MTBF	54 Years
PFD _{avg}	2.29 x 10 ⁻⁵ (For T1 = 1 year)

5 Safety notes



WARNING: Risk of electric shock

During operation, parts of electrical switching devices carry hazardous voltages.

Before working on the switching device, disconnect the power.

Please observe the safety regulations of electrical engineering and industrial safety and liability associations!

Disregarding these safety regulations may result in death, serious personal injury or damage to equipment.

Startup, mounting, modifications, and upgrades should only be carried out by a skilled electrical engineer!



WARNING: Risk of automatic machine restart!

For emergency stop applications, the machine must be prevented from restarting automatically by a higher-level control system.

Protective covers must not be removed when operating electrical switching devices.



WARNING: Danger due to faulty devices!

The devices may be damaged following an error and correct operation can no longer be ensured.

In the event of an error, replace the device immediately.

Repairs to the device, especially if the housing must be opened, may only be carried out by the manufacturer or authorized persons. Otherwise the warranty is invalidated.



WARNING: Risk due to incorrect installation

For reliable operation, the safety relay must be installed in housing protected from dust and humidity (IP54).

Carry out wiring according to the application. Refer to the "Application examples" section for this.



WARNING: Risk due to welded relay contacts

A suitable and effective protective circuit is to be provided for inductive loads. This is to be implemented parallel to the load and not parallel to the switch contact.



WARNING: danger due to magnetic interference!

Do not use the device in the vicinity of strong magnetic fields (e.g., caused by transformers or magnetic iron). The magnetic field strength of the environment must not exceed 30 A/m.



NOTE: Risk of damage to equipment due to noise emissions

When operating relay modules the operator must meet the requirements for noise emission for electrical and electronic equipment (EN 61000-6-4) on the contact side and, if required, take appropriate measures.



NOTE: Risk of damage to equipment due to noise emissions

This is a Class A product. In a domestic environment it may cause radion interference, in which case the user may be required to take adequate measures.



Only use power supply units with safe isolation and SELV / PELV in accordance with EN 50178/VDE 0160 (SELV / PELV).

5.1 Installation in the Ex area (class I, zone 2)



WARNING: Explosion hazard

The device should be installed in a housing (control or distributor box) that fulfills the requirements of EN 60079-15:2010 (IEC 60079-15:2010 4th ED.) and at least IP54 (EN/ IEC 60529) degree of protection.



WARNING: Explosion hazard

The device must be used in no more than a pollution degree 2 environment as defined by EN/ IEC 60664-1.



WARNING: Explosion hazard

When installing and connecting the supply and signal circuits observe the requirements of EN/ IEC 60079-14. Only devices suitable for operation in Ex zone 2 and the conditions at the application site may be connected to the circuits in zone 2.

In potentially explosive areas, only connect and disconnect cables when the power is disconnected.



WARNING: Explosion hazard

The device must be stopped and immediately removed from the Ex area if it is damaged or was subject to an impermissible load or stored incorrectly or if it malfunctions.

Ambient temperature in hazardous areas (class I, zone 2)

Observe the derating curves.

Observe the special temperature conditions according to the rating plate.

	NO-contact	DO-contact
Output	250 V AC / 24 V DC 6 A, Resistive B300, R300	24 V DC 100 mA Resistive
Ambient Temperature	-20 °C to 65 °C	

5.2 Installation in areas with a danger of dust explosions



WARNING: Explosion hazard

The device is not designed for use in atmospheres with a danger of dust explosions.

6 Basic circuit diagram

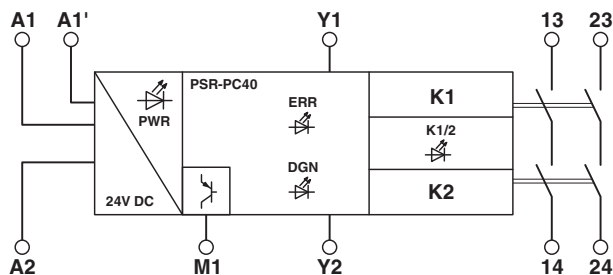

Figure 1 Block diagram

Key:

Designation	Explanation
A1	+24 V control input with active error acknowledgment
A2	0 V (GND)
A1'	+24 V control input without active error acknowledgment
M1	Signal output (PNP)
Y1	+24 V start circuit output
Y2	+24 V start circuit input
13/14	Undelayed enabling current paths
23/24	

7 Derating

7.1 Vertical mounting position

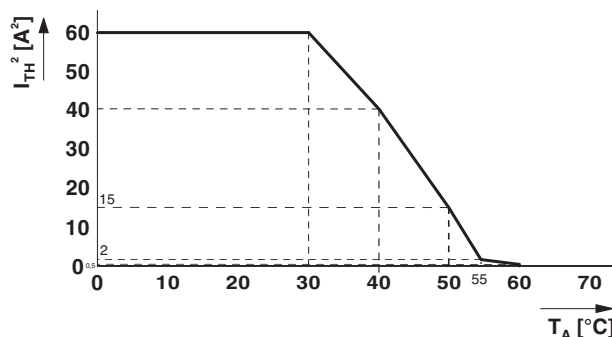

Figure 2 Derating curve - vertical mounting position with connected modules

Expanded ambient temperature range (with 10 mm distance): up to +70 °C

Conditions:

Max. rated control supply voltage 26.4 V DC
 Max. total current of the enabling current path 60 A²

7.2 Horizontal mounting position

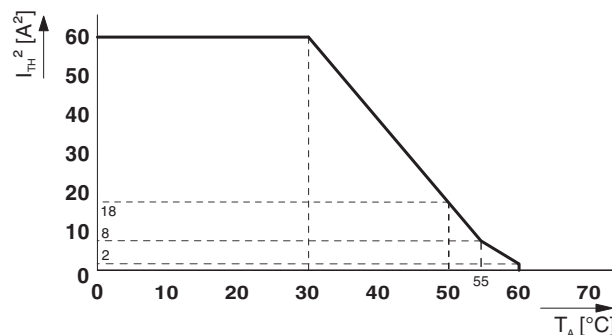

Figure 3 Derating curve - horizontal mounting position with connected modules

Expanded ambient temperature range (with 10 mm distance): up to +70 °C

Conditions:

Max. rated control supply voltage 26.4 V DC
 Max. total current of the enabling current path 60 A²

7.3 Mounting position with module front at the top

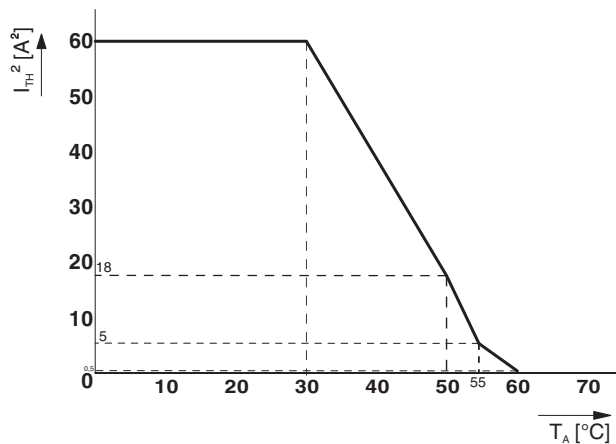

Figure 4 Derating curve - mounting position with module front at the top and aligned modules

Expanded ambient temperature range (with 10 mm distance): up to +70 °C

Conditions:

- Max. rated control supply voltage 26.4 V DC
- Max. total current of the enabling current path 60 A²

8 Load curve

8.1 Ohmic load

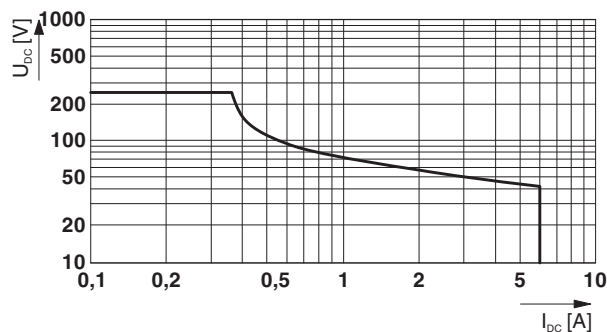

Figure 5 Relay load curve - ohmic load

9 Operating and indication elements

9.1 Connection versions

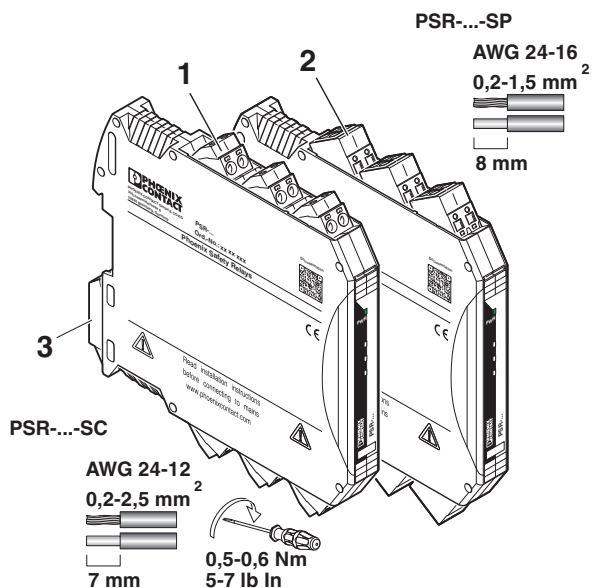

Figure 6 Connection versions

- 1 COMBICON plug-in screw terminal block
- 2 COMBICON plug-in spring-cage terminal block
- 3 Metal lock for fixing to DIN rail

i The year the device was constructed can be found underneath the CE designation on the housing.

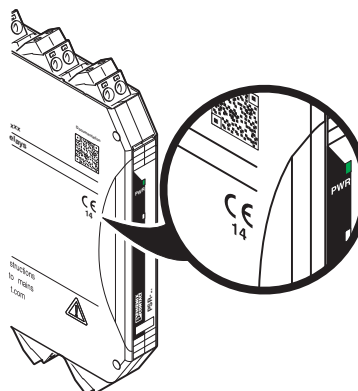

Figure 7 Year of manufacture of the device

9.2 Connection assignment

Figure	Designation	Explanation
	M1	Signal output (PNP)
	A1'	+24 V control input without active error acknowledgment
	Y1	+24 V start circuit output
	Y2	+24 V start circuit input
	A1	+24 V control input with active error acknowledgment
	A2	0 V (GND)
	PWR	Power LED (yellow)
	ERR	Error LED (red)
	DGN	Diagnostics LED (green)
	K1/K2	Status indicator safety circuit; LED (green)
	13/14	Undelayed enabling current paths
	23/24	
	Y1	Y2

10 Mounting and connection

Mount the module on a 35 mm DIN rail according to EN 60715.

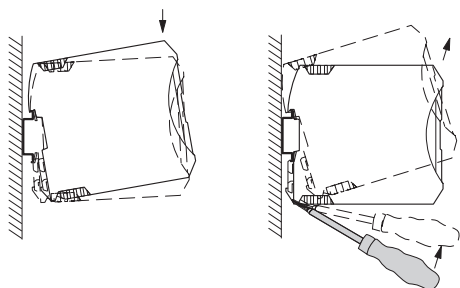

Figure 8 Mounting and removing

Connect the cables to the connection terminal blocks using a screwdriver.

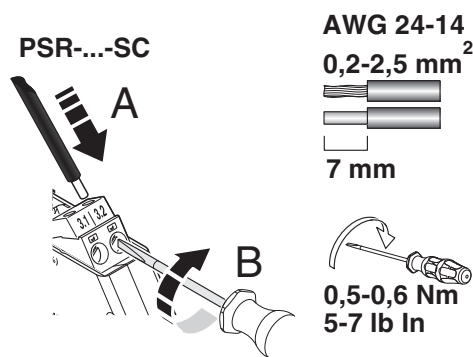

Figure 9 Connecting the cables for PSR-...-SC (screw terminal block)

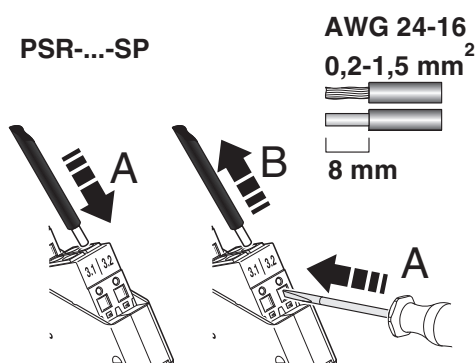

Figure 10 Connecting the cables for PSR-...-SC (spring-cage terminal block)



For compliance with UL approval, use copper wire that is approved up to 60°C/75°C.

11 Startup

Apply the rated control supply voltage to terminals A1/A2 (with active error acknowledgement) or A1'/A2 (without active error acknowledgement) and connect the Y1/Y2 feedback circuit. The PWR LED, the K1/2 LED, and the DGN LED light up.

Close enabling current paths 13/14 and 23/24.

12 Proof test

In the proof test, you check the individual relay channels.

1. Deactivate A1 (or A1').
2. Ensure that the Y1/Y2 feedback circuit is closed.
3. Activate A1/A2 (or A1'/A2).

If the yellow PWR LED, the green K1/2 LED, and the green DGN LED light up, the module is functional.

The enable contacts are closed.

(Apply 0 V DC to signal output M1. Error acknowledgment via A1 is inactive.)

If the yellow PWR LED and the red ERR LED light up, replace the module.

The module-internal locking prevents the enable contacts from being closed.

(Apply 24 V DC to signal output M1. Error acknowledgment via A1 is inactive.)



Replace the device in the event of an error.

13 Calculating the power dissipation



The total power dissipation of the safety relay is based on the input power dissipation and the contact power dissipation for the same and for different load currents.

Input power dissipation

$$P_{\text{Input}} = U_B^2 / (U_S / I_S)$$

Contact power dissipation

With the same load currents:

$$P_{\text{Contact}} = n \cdot I_L^2 \cdot 50 \text{ m}\Omega$$

With different load currents:

$$P_{\text{Contact}} = (I_{L1}^2 + I_{L2}^2 + \dots + I_{Ln}^2) \cdot 50 \text{ m}\Omega$$

Total power dissipation

$$P_{\text{Total}} = P_{\text{Input}} + P_{\text{Contact}}$$

therefore

$$P_{\text{Total}} = U_B^2 / (U_S / I_S) + n \cdot I_L^2 \cdot 50 \text{ m}\Omega$$

or

$$P_{\text{Total}} = U_B^2 / (U_S / I_S) + (I_{L1}^2 + I_{L2}^2 + \dots + I_{Ln}^2) \cdot 50 \text{ m}\Omega$$

Key:

Designation	Explanation
P	Power dissipation in mW
U_B	Applied operating voltage
U_S	Rated control supply voltage
I_S	Rated control supply current
n	Number of enabling current paths used
I_L	Contact load current

14 Application examples

Key:

- SIS = Safety Instrumented System (safe control)
- DC = Diagnostic Coverage according to IEC 61508 (line/load diagnostics at DO)
- DI = Digital input
- DO = Digital output
- K1/K2 = Contactors

Applications with the PSR-PC40

14.1 Application example 1 - SIL 3

- Low-demand application
- Single-channel control
- Automatic activation
- Monitoring of external contactors

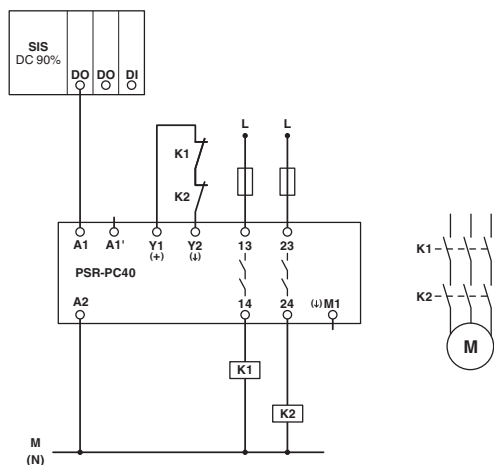

Figure 11 Application example 1 - SIL 3

Data for the application example as 1001 structure	
Equipment type	A
HFT	0
SIL	3
SFF	99.71 %
λ_{SD}	0 FIT
λ_{SU}	1798 FIT
λ_{DD}	0 FIT
λ_{DU}	5.236 FIT
λ_{Total}	1803 FIT
MTBF	54 years
PFD_{avg}	2.29×10^{-05} (for T1 = 1 year)

14.2 Application example 2 - SIL 3

- Low-demand application
- Single-channel control
- Automatic activation
- Controlling valves (for example)

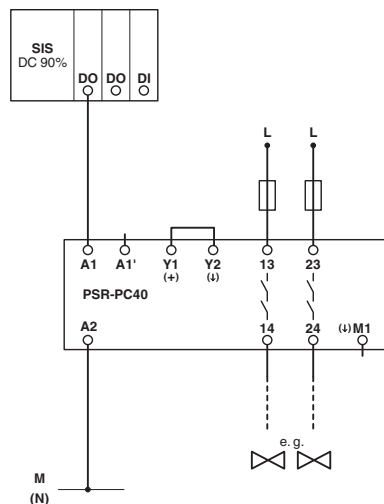

Figure 12 Application example 2- SIL 3

Data for the application example as 1001 structure	
Equipment type	A
HFT	0
SIL	3
SFF	99.71 %
λ_{SD}	0 FIT
λ_{SU}	1798 FIT
λ_{DD}	0 FIT
λ_{DU}	5.236 FIT
λ_{Total}	1803 FIT
MTBF	54 years
PFD_{avg}	2.29×10^{-05} (for T1 = 1 year)

15 Revision history

Version	Date	Contents
00	2015-03-10	First publication
01	2015-04-29	Info box for application example 1 deleted
02	2015-07-01	Application example 2 added
03	2015-07-14	Texts / safety notes for ATEX deleted