



Chipsmall Limited consists of a professional team with an average of over 10 year of expertise in the distribution of electronic components. Based in Hongkong, we have already established firm and mutual-benefit business relationships with customers from,Europe,America and south Asia,supplying obsolete and hard-to-find components to meet their specific needs.

With the principle of “Quality Parts,Customers Priority,Honest Operation,and Considerate Service”,our business mainly focus on the distribution of electronic components. Line cards we deal with include Microchip,ALPS,ROHM,Xilinx,Pulse,ON,Everlight and Freescale. Main products comprise IC,Modules,Potentiometer,IC Socket,Relay,Connector.Our parts cover such applications as commercial,industrial, and automotives areas.

We are looking forward to setting up business relationship with you and hope to provide you with the best service and solution. Let us make a better world for our industry!



Contact us

Tel: +86-755-8981 8866 Fax: +86-755-8427 6832

Email & Skype: info@chipsmall.com Web: www.chipsmall.com

Address: A1208, Overseas Decoration Building, #122 Zhenhua RD., Futian, Shenzhen, China



AXL E EIP DI16 M12 6M

**Axioline E EtherNet/IP™ device,
metal housing, 16 inputs, 24 V DC,
M12 fast connection technology**



Data sheet
8421_en_01

© PHOENIX CONTACT 2015-09-24

1 Description

The Axioline E device is designed for use within an EtherNet/IP™ network.

It is used to acquire digital signals.

The device is designed for use in systems manufacturing.

It is suitable for use without a control cabinet under harsh industrial conditions.

The Axioline E device can be used on tool platforms, directly on welding robots or in conveying technology, for example.

EtherNet/IP™ features

- 2 Ethernet ports (with integrated switch)
- Minimum cycle time of 1 ms (RPI)
- Supported protocols: ACD, DLR, IGMP v2, SNMP v1, HTTP, TFTP, FTP, BootP, DHCP
- Specification: CIP Edition 3.11; EIP adaptation of CIP 1.12
- Device description using EDS file
- Firmware can be updated
- Integrated web server for web-based management

Axioline E features

- Connection to EtherNet/IP™ network using M12 connectors (D-coded)
- Transmission speed of 10 Mbps and 100 Mbps
- Connection of digital sensors to M12 connectors (A-coded)
- Diagnostic and status indicators
- Short-circuit and overload protection of the sensor supply
- IP65/67 degree of protection



This data sheet is only valid in association with the associated user manual.



Make sure you always use the latest documentation.
It can be downloaded from the product at phoenixcontact.net/products.

2	Table of contents	
1	Description	1
2	Table of contents	2
3	Ordering data	3
4	Technical data	4
5	Internal circuit diagram	7
6	Pin assignment	8
7	Connection example.....	10
8	Connection notes	10
9	Configuration via rotary encoding switch	11
10	Local status and diagnostic indicators	13
11	EtherNet/IP™ object classes, messages, and services.....	15
12	EtherNet/IP™ Assembly instances.....	24
13	Startup.....	25
14	SNMP - Simple Network Management Protocol	26
15	DLR - Device Level Ring.....	26
16	WBM - Web-based management	26
17	Firmware update.....	26
18	Quick Connect.....	26
19	Connection types.....	26
20	Device description (EDS)	26

3 Ordering data

Description	Type	Order No.	Pcs. / Pkt.
Axioline E EtherNet/IP™ device in a metal housing with 16 digital inputs, 24 V DC, M12 fast connection technology	AXL E EIP DI16 M12 6M	2701488	1

Accessories	Type	Order No.	Pcs./Pkt.
An M12 screw plug for the unoccupied M12 sockets of the sensor/actuator cable, boxes and flush-type connectors (Protection and sealing elements)	PROT-M12	1680539	5
Mounting plate for Axioline E metal devices (Assembly)	AXL E MP 60	2701761	1
Snap-in markers, Sheet, white, unlabeled, can be labeled with: THERMOMARK CARD, BLUEMARK CLED, BLUEMARK LED, TOPMARK LASER, Mounting type: snapped into marker carrier, Lettering field: 7 x 10 mm (Marking)	UCT-EM (7X10)	0830765	10

Documentation	Type	Order No.	Pcs. / Pkt.
User manual, English, Axioline E: system and installation	UM EN AXL E SYS INST	-	-
Application note, English: Updating the firmware of AXL E devices using the Windows Explorer	AH EN FIRMWARE UPDATE AXL E	-	-

Additional ordering data

For additional accessories, visit phoenixcontact.net/products.

4 Technical data

Dimensions (nominal sizes in mm)

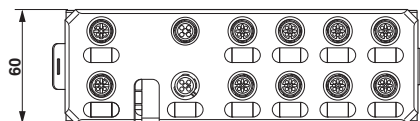
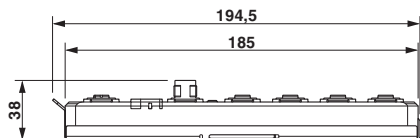

Width	60 mm
Height	185 mm
Depth	38 mm

Note on dimensions

The height is 194.5 mm including the mounting plate. With fixing clips pulled out, the height is 212 mm. The depth is 38 mm including the mounting plate (30.5 mm without the mounting plate).

General data

Housing material	Zinc die-cast
Weight	750 g
Ambient temperature (operation)	-25 °C ... 60 °C



CAUTION: Risk of burns

If the device is used at an ambient temperature above 50°C, the contact temperature of metal surfaces may exceed 70°C.

Ambient temperature (storage/transport)	-25 °C ... 85 °C
Permissible humidity (operation)	5 % ... 95 %
Permissible humidity (storage/transport)	5 % ... 95 %
Air pressure (operation)	80 kPa ... 108 kPa (up to 3000 m above sea level)
Air pressure (storage/transport)	70 kPa ... 106 kPa (up to 3000 m above sea level)
Degree of protection	IP65/67
Protection class	III, IEC 61140, EN 61140, VDE 0140-1

Connection data

Connection method	M12 connector
-------------------	---------------

Interface EtherNet/IP™

Number	2
Connection method	M12 connectors, D-coded
Designation connection point	Copper cable
Number of positions	4
Transmission speed	10/100 MBit/s (with auto negotiation)
Cycle Time	min. 1 ms (RPI)

EtherNet/IP™

Equipment type	EtherNet/IP™ slave
EtherNet/IP™ protocols	ACD, DLR, IGMP v2
Additional protocols	SNMP v1, HTTP, TFTP, FTP, BootP, DHCP
Specification	CIP Edition 3.11 EIP adaptation of CIP 1.12

Supply: Module electronics and sensors (U_S)

Connection method	M12 connector (T-coded)
Number of positions	4
Supply voltage	24 V DC
Nominal supply voltage range	18 V DC ... 31.2 V DC (including all tolerances, including ripple)
Typical current consumption	190 mA ±15 % (at 24 V DC)
Current consumption	max. 12 A

Supply: Actuators (U_A) for additional devices

Connection method	M12 connector (T-coded)
Number of positions	4
Supply voltage	24 V DC
Nominal supply voltage range	18 V DC ... 31.2 V DC (including all tolerances, including ripple)
Typical current consumption	3 mA ±15 % (at 24 V DC)
Current consumption	max. 12 A

Digital inputs

Number of inputs	16 (EN 61131-2 types 1 and 3)
Connection method	M12 connector, double occupancy
Connection method	2, 3, 4-wire
Nominal input voltage	24 V DC
Nominal input current	typ. 3 mA
Sensor current per channel	typ. 0.75 mA (from U _S)
Total sensor current	max. 1.2 A (per device)
Input voltage range "0" signal	-30 V DC ... 5 V DC
Input voltage range "1" signal	11 V DC ... 30 V DC
Input filter time	< 1000 µs
Permissible conductor length to the sensor	30 m
Overload protection, short-circuit protection of sensor supply	Yes

Electrical isolation/isolation of the voltage areas

Test section	Test voltage
24 V supply (communications power and sensor supply, digital inputs)/ bus connection (Ethernet 1)	500 V AC, 50 Hz, 1 min
24 V supply (communications power and sensor supply, digital inputs)/ bus connection (Ethernet 2)	500 V AC, 50 Hz, 1 min
24 V supply (communications power and sensor supply, digital inputs)/FE	500 V AC, 50 Hz, 1 min
Bus connection (Ethernet 1)/FE	500 V AC, 50 Hz, 1 min
Bus connection (Ethernet 2)/FE	500 V AC, 50 Hz, 1 min
Bus connection (Ethernet 1)/bus connection (Ethernet 2)	500 V AC, 50 Hz, 1 min
24 V supply (actuator supply)/ 24 V supply (communications power and sensor supply, digital inputs)	500 V AC, 50 Hz, 1 min
24 V supply (actuator supply)/bus connection (Ethernet 1)	500 V AC, 50 Hz, 1 min
24 V supply (actuator supply)/bus connection (Ethernet 2)	500 V AC, 50 Hz, 1 min
24 V supply (actuator supply)/FE	500 V AC, 50 Hz, 1 min

Mechanical tests

Vibration resistance in acc. with EN 60068-2-6/IEC 60068-2-6	5 g
Shock in acc. with EN 60068-2-27/IEC 60068-2-27	30 g, 11 ms period, half-sine shock pulse
Continuous shock according to EN 60068-2-27/IEC 60068-2-27	10 g

Conformance with EMC Directive 2004/108/EC

Noise immunity test in accordance with EN 61000-6-2

Electrostatic discharge (ESD) EN 61000-4-2/IEC 61000-4-2	Criterion B; 6 kV contact discharge, 8 kV air discharge
Electromagnetic fields EN 61000-4-3/IEC 61000-4-3	Criterion A; Field intensity: 10 V/m
Fast transients (burst) EN 61000-4-4/IEC 61000-4-4	Criterion B, 2 kV
Transient surge voltage (surge) EN 61000-4-5/IEC 61000-4-5	Criterion B; DC supply lines: ± 0.5 kV/ ± 0.5 kV (symmetrical/asymmetrical)
Conducted interference EN 61000-4-6/IEC 61000-4-6	Criterion A; Test voltage 10 V

Noise emission test as per EN 61000-6-4

Radio interference properties EN 55022	Class A
--	---------

Approvals

For the latest approvals, please visit phoenixcontact.net/products.

5 Internal circuit diagram

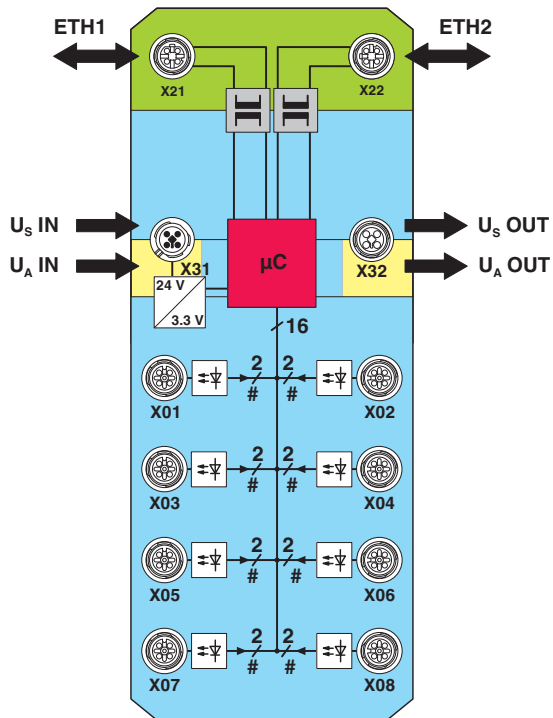

Key:



Transmitter with electrical isolation



Power supply unit with electrical isolation



Microcontroller



Digital input



LED

Figure 1 Internal wiring of connections

Key:

Green area:	Network
Blue area:	U_S
Yellow area:	U_A

6 Pin assignment

6.1 EtherNet/IP™ and power supply connection

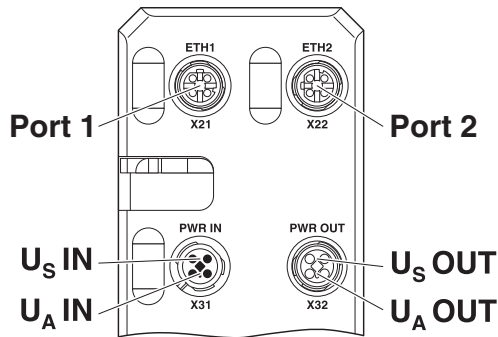

Figure 2 Connections for EtherNet/IP™ and voltage supply

Designation	Meaning
Port 1 (X21)	Ethernet port 1
Port 2 (X22)	Ethernet port 2
U _S IN (X31)	Power supply IN (logic and sensors)
U _A IN (X31)	Power Supply IN (actuators) for additional devices
U _S OUT (X32)	Power supply OUT for additional devices
U _A OUT (X32)	Power supply OUT for additional devices



Ground the device by means of the mounting screws.

6.2 EtherNet/IP™ pin assignment

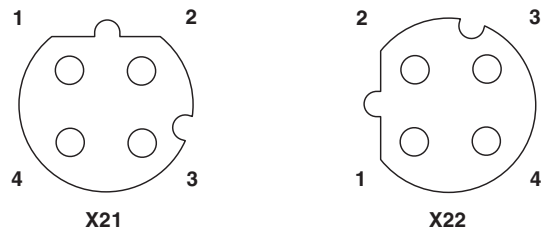

Figure 3 Ethernet pin assignment, D-coded

Pin	Ethernet port 1 (X21)	Ethernet port 2 (X22)
1	TX+	TX+
2	RX+	RX+
3	TX-	TX-
4	RX-	RX-



The shield is connected to FE in the device.



The thread is used for additional shielding.

6.3 Pin assignment of the power supply U_S/U_A

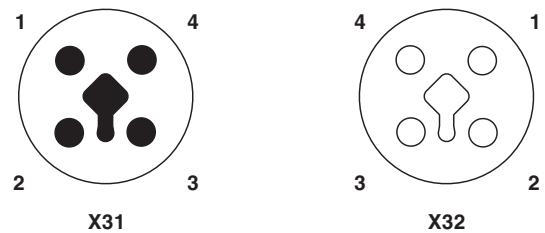

Figure 4 Pin assignment of the power supply, T-coded

Pin	IN	OUT	Conductor colors
1	+24 V DC (U _S)	+24 V DC (U _S)	Brown
2	GND (U _A)	GND (U _A)	White
3	GND (U _S)	GND (U _S)	Blue
4	+24 V DC (U _A)	+24 V DC (U _A)	Black

6.4 Input connection

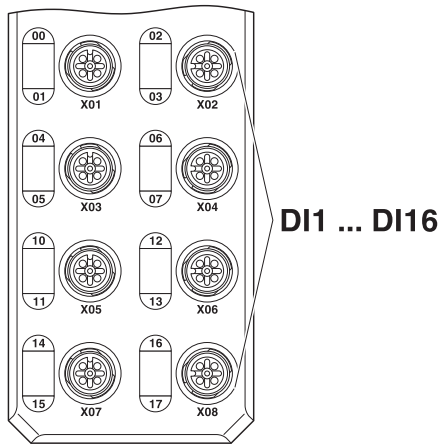

Figure 5 Input connections

Designation	Meaning
DI1 ... DI16 (X01 ... X08)	Inputs 1 ... 16

6.5 Pin assignment of the inputs

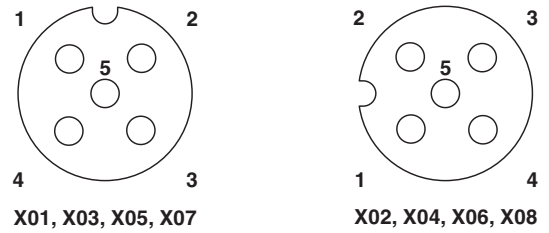

Figure 6 Pin assignment of the inputs, A-coded

Pin	Input socket
1	+24 V DC (U_S)
2	Input 2, 4, 6, ... 16
3	GND
4	Input 1, 3, 5, ... 15
5	FE

7 Connection example

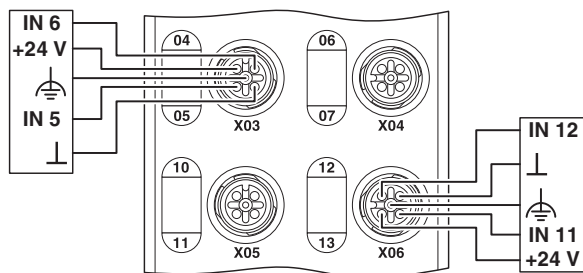

Figure 7 Typical connection of sensors

8 Connection notes



Note: data corruption or loss

Implement the FE connection using mounting screws, in order to ensure immunity to interference.



NOTE: device damage

To ensure IP65/IP67 protection, cover unused sockets with protective caps.



NOTE: Damage to the electronics

Only supply the sensors with the voltage U_S provided at the terminal points.



NOTE: Damage to the electronics

Observe the correct polarity of the supply voltages U_S and U_A in order to prevent damage to the device.



NOTE: Malfunction

When connecting the sensors, observe the assignment of the connections to the EtherNet/IP™ input data.



Secure the device to a level surface or to a profile. Do not use this device to bridge gaps, in order to prevent forces being transmitted via the device.



Use standard M5 screws with toothed lock washer and self-locking nuts. Observe the maximum torque of the screws.

9 Configuration via rotary encoding switch

You can configure the address assignment and other functions using rotary encoding switches.

After modifying the switch position, restart the device, as the modification to the switch position does not take effect during operation.

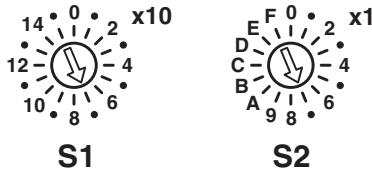

Figure 8 Rotary encoding switch

The code results from the sum of $S1 \times 10$ plus $S2 \times 1$. The image shows code 77 ($7 \times 10 + 7$).

S1	S2	Code	Function
0	0	00	Remote access (default)
0 ... 5	1 ... 0	01 ... 50	Manual address assignment
5 ... 15	0 ... 9	51 ... 159	DHCP name assignment
0	A	0A	Fixed address
0	E	0E	Resetting IP parameters
0	F	0F	Resetting to the default settings
Other			Reserved

9.1 Remote access

Switch position 00

At this switch position, it is possible to remotely configure the device using corresponding tools (e.g., Startup+, web-based management (WBM)).

Behavior during initial startup, after resetting the IP parameters or after resetting to default settings

A valid IP address is not assigned (0.0.0.0) and communication is therefore not possible.

The device transmits continuous BootP requests (2 s, 4 s, 8 s, 2 s ...), until a valid IP address has been received.

Valid IP parameters are then automatically saved as configuration data on the device.

Each additional startup

If BootP is not explicitly deactivated, the device transmits continuous BootP requests (2 s, 4 s, 8 s, 2 s, etc.), until a valid IP address has been received.

Valid IP parameters are then automatically saved as configuration data on the device.

9.2 Manual address assignment

Switch position 01 ... 50

Default: BootP deactivated, DHCP activated

The first three octets in the IP address are preset as 192.168.0.x.

The subnet mask is 255.255.255.0.

Specify the last byte with the switch position.

As such, you can select IP addresses between 192.168.0.1 and 192.168.0.50.

Prior to transferring the IP address, a test is performed to check for any potential IP address conflicts. If a conflict is detected, the device temporarily switches the IP address to 0.0.0.0 (no IP communication). In this case, the NET LED flashes red. Eliminate the conflict and restart the device.

9.3 DHCP name assignment

Switch position 51 ... 159

This switch position is used to easily specify the DHCP host name for the device.

The host name is provided to the DHCP server via DHCP options. This is therefore able to send a DNS update to the DNS server.

The DNS name consists of one set part, which is based on the order designation, and a variable part, which is determined by the switch position.

The first part of the station name is AXL-E-EIP-.

The set number is added.

This results in the following station names: AXL-E-EIP-051 ... AXL-E-EIP-159.

Behavior during initial startup, after resetting the IP parameters or after resetting to default settings

A valid IP address is not assigned (0.0.0.0) and communication is therefore not possible.

The device transmits continuous DHCP discover messages until a valid IP address has been received.

Each additional startup

The device transmits continuous DHCP requests.

There are two possible scenarios:

1. The DHCP server assigns a new IP address.
⇒ The device applies the new IP parameters.
2. The DHCP server does not respond.
⇒ The device transmits continuous DHCP Discover messages until new IP parameters have been received.

9.4 Fixed address

Switch position 0A

Behavior during initial startup, after resetting the IP parameters or after resetting to default settings

A valid IP address is not assigned (0.0.0.0) and communication is therefore not possible.

Assign an address initially with another switch position.

Each additional startup

After a voltage reset, the device maintains the IP address which was assigned last.



With this switch position, modifying the IP address via tools or web-based management is not possible.

9.5 Resetting IP parameters

Switch position 0E

The IP parameters stored on the device are reset.

All other settings made on the device are retained.

- BootP is activated for switch position 00.
- IP address, subnet mask: 0.0.0.0

As long as the switch position 0E remains selected, no connection to the device can be established.

IP communication is deactivated (LED NET static yellow).

9.6 Resetting to the default settings

Switch position 0F

All settings are reset to default settings, including IP parameters.



The device is ready for operation after powering up, as soon as the RDY LED lights up green.
A connection to the device however cannot be established in this switch position.
As soon as the RDY LED lights up green, a new switch position can be selected on the rotary encoding switch and the device can be restarted.

9.7 Reserved/invalid switch position

The device starts with the previous settings, e.g., with the settings that were valid before the device was restarted.

An invalid switch position is indicated by the RDY LED (red on).

10 Local status and diagnostic indicators

10.1 Indicators for Ethernet ports and power supply

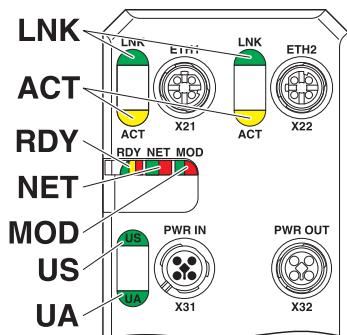

Figure 9 Indicators for Ethernet ports and power supply

Designation	Color	Meaning	State	Description
LNK 1/2	Green	Link	Green ON	Connection present at port 1/2.
			OFF	Connection not present at port 1/2.
ACT 1/2	Yellow	Activity	Yellow ON	Data transmission present at port 1/2.
			OFF	Data transmission not present at port 1/2.
RDY	Green/ yellow/ red	Ready	Green ON	Device is ready for operation.
			Yellow flashing	Firmware update is being performed.
			Flashing green/ yellow	Over- or undervoltage at U_S
				Temperature of the device is in the critical area.
				Failure of the actuator supply U_A And red US LED: sensor supply overload
			Red ON	Rotary encoding switches are set to an invalid/reserved position.
OFF	Device is not ready for operation.			
NET	Green/ red	Network status	Green ON	At least one CIP connection is in place and the exclusive owner connection has no timeout.
			Green flashing	An IP address is configured, no CIP connection is yet in place, and the exclusive owner connection has no timeout.
			Red ON	Duplicate IP. ACD has determined an IP address conflict.
			Red flashing	Connection timeout. A timeout of an exclusive owner connection has occurred.
			Flashing green/ red	Self test
			OFF	Device is not ready for operation.

Designation	Color	Meaning	State	Description
MOD	Green/ red	Module status	Green ON	Normal operation
			Green flashing	The device is not configured.
			Red ON	A recoverable error has occurred.
			Red flashing	A unrecoverable error has occurred.
			Flashing green/ red	Self test
			OFF	Device is not ready for operation.
US	Green/ red	U _{Sensorik}	Green ON	Communications power/sensor voltage present
			OFF	Communications power/sensor voltage not present or too low.
			Red ON	Sensor voltage overload
UA	Green	U _{Aktorik}	ON	Actuator voltage present.
			OFF	Actuator voltage not present.

10.2 Input indicators

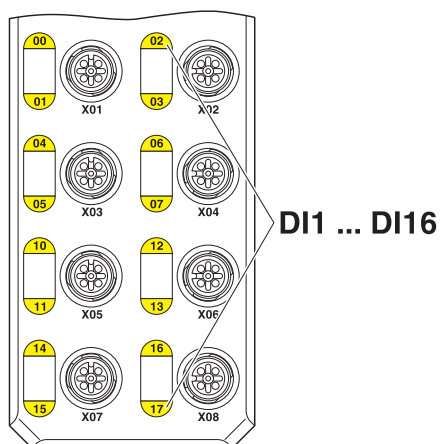

Figure 10 LEDs of the inputs

Designation	Color	Meaning	State	Description
00 ... 07, 10 ... 17	Yellow	Status of the inputs	ON	Input is set.
			OFF	Input is not set.



The numbering of the LEDs is as follows: the first number specifies the byte, the second number specifies the bit.

11 EtherNet/IP™ object classes, messages, and services

The device supports the Common Industrial Protocol (CIP) by using digital input points (DIPs) and digital output points (DOPs) according to the ODVA specification. EtherNet/IP™ uses the Common Industrial Protocol (CIP) as the application layer. IP and TCP or UDP are used for the network and transport layers. CIP and EtherNet/IP™ are standardized by the ODVA on a manufacturer-neutral basis. The Common Industrial Protocol is an object-oriented protocol with two different types of communication between a controller and termination devices.

The following table describes the two communication types.

Connection type	Description
Explicit messaging	This means that a controller or an engineering system sends a request and the termination device responds. For example, explicit messaging can be used for configuration and/or diagnostics.
Implicit messaging	Implicit messaging is used for the cyclic transmission of I/O data. That means, for example, that a termination device sends an analog value which is present at a termination device input. The time for a transmission cycle can be set via the requested packet interval (RPI).

11.1 CIP class services

The device supports the following class services and instance services:

Service code		Service name
dec	hex	
01	01	Get_Attribute_All
02	02	Set_Attribute_All
05	05	Reset
09	09	Delete
14	0E	Get_Attribute_Single
16	10	Set_Attribute_Single

11.2 CIP object classes

The device supports the following CIP object classes:

Class code		Object type
dec	hex	
01	01	Identity object
04	04	Assembly object
06	06	Connection manager object
08	08	Digital input point object
71	47	Device level ring object
72	48	Quality of Service object
245	F5	TCP/IP interface object
246	F6	Ethernet link object

11.3 Identity object (class code 01_{hex})

The Identity object is required by all devices and provides the device ID and general information about the device.

Class attributes

Attribute	Name	Access	Data type	Value
1	Version	Get	UINT	1
2	Max instance	Get	UINT	1
6	Max class attribute	Get	UINT	7
7	Max instance attribute	Get	UINT	10

Instance attributes

Attribute	Name	Access	Data type	Value	
1	Vendor ID	Get	UINT	562	
2	Device type	Get	UINT	General purpose discrete I/O	
3	Product code	Get	UINT	8174	
4	Revision	Get	STRUC of:	1	
	Major revision		USINT	1	
	Minor revision		USINT	1	
5	Status	Get	WORD	Bit 0	Owned
				Bit 1	Reserved
				Bit 2	Configured
				Bit 3	Reserved
				Bit 4 ... Bit 7	Extended device status
				Bit 8	Minor recoverable fault
				Bit 9	Minor unrecoverable fault
				Bit 10	Major recoverable fault
				Bit 11	Major unrecoverable fault
				Bit 12 ... Bit 15	Extended device status 2
6	Serial number	Get	UDINT	Is fixed in production process	
7	Product name	Get	STRING	AXL E EIP DI16 M12 6M	
8	State	Get	USINT	0 = Nonexistent	
				1 = Device self testing	
				2 = Standby	
				3 = Operational	
				4 = Major recoverable fault	
				5 = Major unrecoverable fault	
				6 ... 254 = Reserved	
				255 = Default for Get_Attribute_All service	
9	Configuration consistency value	Get	USINT	CRC checksum	

Common services

Service code		Class	Instance	Service name
dec	hex			
01	01	Yes	Yes	Get_Attribute_All
05	05	No	Yes	Reset
14	0E	Yes	Yes	Get_Attribute_Single
16	10	No	Yes	Set_Attribute_Single

11.4 Assembly object (class code 4_{hex})

The Assembly object combines attributes of multiple objects to allow data to or from each object to be sent or received via a single connection.

Class attributes

Attribute	Name	Access	Data type	Value
1	Version	Get	UINT	2
2	Max instance	Get	UINT	102

Instance attributes

Attribute	Name	Access	Data type	Description
3	Data	Get, Set	ARRAY of Byte	Current Process data of the correspondent Assembly instance
4	Size	Get	UINT	Number of bytes in attribute 3

Common services

Service code		Class	Instance	Service name
dec	hex			
14	0E	Yes	Yes	Get_Attribute_Single
16	10	No	Yes	Set_Attribute_Single

11.5 Connection manager object (class code 06_{hex})

Class attributes

Attribute	Name	Access	Data type	Value
1	Version	Get	UINT	1
2	Max instance	Get	UINT	1

11.6 Discrete Input Point object (class code 08_{hex})

The Digital input point (DIP) object mirrors the digital inputs. This object can be used in simple toggle switches as well as in complex I/O control modules. Each device has a separate instance for each digital input.

Class attributes

Attribute	Name	Access	Data type	Value
1	Version	Get	UINT	2

Instance attributes

Attribute	Name	Access	Data type	Value
3	Value	Get	BOOL	0 = off; 1 = on
4	Status	Get	BOOL	0 = OK; 1 = Fault

Common services

Service code		Class	Instance	Service name
dec	hex			
14	0E	Yes	Yes	Get_Attribute_Single
16	10	No	Yes	Set_Attribute_Single

11.7 Device level ring object (class code 47_{hex})

Class attributes

Attribute	Name	Access	Data type	Value
1	Version	Get	UINT	2

Instance attributes

Attribute	Name	Access	Datentyp	Wert/ Beschreibung	
1	Network topology	Get	USINT	0 = Linear 1 = Ring	
2	Network status	Get	USINT	0 = Normal 1 = Ring fault 2 = Unexpected loop detected 3 = Partial network fault 4 = Rapid fault/Restore cycle	
10	Active supervisor address	Get	STRUCT of:	IP and/or MAC address of the active ring supervisor	
			UDINT	Supervisor IP address	
			ARRAY of 6 USINTs	Supervisor MAC address	
12	Capability flags	Get	DWORD	Bit 0	Announced-based ring node
				Bit 1	Beacon-based ring note
				Bit 2 ... Bit 4	Reserved
				Bit 5	Supervisor capable
				Bit 6 ... Bit 31	Reserved

Common services

Service code		Class	Instance	Service name
dec	hex			
1	01	Yes	Yes	Get_Attribute_Single
14	0E	Yes	Yes	Set_Attribute_Single

11.8 Quality of service object (class code 48_{hex})

Quality of Service (QoS) affects the forwarding and handling of data streams and results in individual data streams being given differential treatment (usually preferential). QoS can be used, e.g., to guarantee a transmission bandwidth for individual data streams. The device uses QoS in connection with prioritization.

Class attributes

Attribute	Name	Access	Data type	Value
1	Version	Get	UINT	1
2	Max instance	Get	UINT	1

Instance attributes

Attribute	Name	Access	Data type	Value/Description
1	802.1Q tag enable	Get, Set	UINT	0 = off (default); 1 = on
4	DSCP urgent	Get, Set	USINT	DSCP value for CIP transport class 0/1 Urgent priority message (default 55)
5	DSCP scheduled	Get, Set	USINT	DSCP value for CIP transport class 0/1 Scheduled priority message (default 47)
6	DSCP high	Get, Set	USINT	DSCP value for CIP transport class 0/1 High priority message (default 43)
7	DSCP low	Get, Set	USINT	DSCP value for CIP transport class 0/1 Low priority message (default 31)
8	DSCP explicit	Get, Set	USINT	DSCP value for CIP explicit messages (transport class 2/3 and UCMM) and all other EtherNet/IP encapsulation messages (default 27)

Common services

Service code		Class	Instance	Service name
dec	hex			
14	0E	Yes	Yes	Get_Attribute_Single
16	10	No	Yes	Set_Attribute_Single

11.9 TCP/IP object (class code F5_{hex})

Class attributes

Attribute	Name	Access	Data type	Value
1	Version	Get	UINT	3
2	Max instance	Get	UINT	1

Instance attributes

Attribute	Name	Access	Data type	Description	
1	Status	Get	DWORD	Bit 0 ... Bit 3	Interface configuration status
				Bit 4	Mcast pending (always 0)
				Bit 5	Interface configuration pending
				Bit 6	AcdStatus
				Bit 7	AcdFault
				Bit 8 ... Bit 31	Reserved
2	Configuration capability	Get	DWORD	Bit 0	BOOTP client
				Bit 1	Not supported
				Bit 2	DHCP client
				Bit 3	Not supported
				Bit 4	TCP/IP config settable via ETH/IP
				Bit 5	Not supported
				Bit 6	Not supported
				Bit 7	AcdCapable
				Bit 8 ... Bit 31	Reserved
3	Configuration control	Get, Set	DWORD	Bit 0 ... Bit 3	0 = The device use static IP configuration 1 = The device use BOOTP 2 = The device use DHCP
				Bit 4	Not supported
				Bit 5 ... Bit 31	Reserved
4	Physical link object	Get	STRUCT of:	Path to Physical link object	
	Path size		UINT	4	
	Path		Padded EPATH	0x20, 0xF6, 0x25, 0x01	

Attribute	Name	Access	Data type	Description
5	Interface configuration	Get, Set	STRUCT of:	TCP/IP network interface configuration
	IP address		UDINT	The device's IP address
	Network mask		UDINT	The device's network mask
	Gateway address		UDINT	Default gateway address
	Name server		UDINT	Primary name server (always 0.0.0.0)
	Name server 2		UDINT	Secondary name server (always 0.0.0.0)
	Domain name		STRING	Default domain name (always empty)
6	Host name	Get, Set	STRING	The device's host name
10	SelectAcid	Get, Set	BOOL	0 = disable; 1 = enable (default)
11	Last conflict detected	Set	STRUCT of:	Structure containing information related to the last conflict detected
	AcidActivity		USINT	State of ACD activity when last conflict detected 0 = NoconflictDetected (default) 1 = Probelpv4Address 2 = OngoingDetection 3 = SemiActiveProbe
	Remote MAC		ARRAY of 6 USINTs	MAC address of remote node from the ARP PDU in which a conflict was detected
	ArpPdu		Array of 28 USINTs	Copy of the raw ARP PDU in which a conflict was detected.
12	Ethernet/IP quick connect	Get, Set	BOOL	0 = disable (default); 1 = enable

Common services

Service code		Class	Instance	Service name
dec	hex			
1	01	Yes	Yes	Get_Attribute_All
14	0E	Yes	Yes	Get_Attribute_Single
16	10	No	Yes	Set_Attribute_Single

11.10 Ethernet link object (class code F6_{hex})

Class attributes

Attribute	Name	Access	Data type	Description
1	Version	Get	UINT	3
2	Max instance	Get	UINT	10
3	Number of instances	Get	UINT	2

Instance attributes

Attribute	Name	Access	Data type	Description	
1	Interface speed	Get	UDINT	Interface speed currently in use. Speed in bps (e.g. 10, 100)	
2	Interface flags	Get	DWORD	Bit 0	Link status
				Bit 1	Half/Full duplex status 0 = Half duplex; 1 = Full duplex
				Bit 2 ... Bit 4	Auto negotiation status 0 = Auto negotiation in progress 1 = Auto negotiation and speed detection failed 2 = Auto negotiation failed but detected speed 3 = Successfully negotiated 4 = Auto negotiation not attempted
				Bit 5	Not supported
				Bit 6	Not supported
3	Physical address	Get	ARRAY of 6 USINTs	MAC layer address	
6	Interface control	Set	STRUC of:	Configuration for physical interface	
	Control bits		WORD	Interface control bits	
			Bit 0	Auto-negotiate (set) 0 = Auto negotiation disabled 1 = Auto negotiation enabled	
			Bit 1	Forced duplex mode (set) 0 = Half duplex ; 1 = Full duplex Set only if auto negotiation is disabled	
Forced interface speed	UINT	The Forced interface speed bits indicate the speed at which the interface shall operate. 10 = 10 Mbps 100 = 100 Mbps Set only if auto negotiation is disabled			
10	Interface lable	Get	STRING	Interface name	

Common services

Service code		Class	Instance	Service name
dec	hex			
1	01	Yes	No	Get_Attribute_All
14	0E	Yes	Yes	Get_Attribute_Single

12 EtherNet/IP™ Assembly instances

	Exclusive owner	Input only	Listen only
Input data length in bytes	-	6	6
Assembly instance	-	101	101
Output data length in bytes	-	0	0
Assembly instance	-	193	192
Configuration data length in bytes	-	-	-
Assembly instance	-	-	-

12.1 Assembly instance 101 (IN process data)

Byte	Function	Description
0 ... 3	Status byte	Status information
4	Input data	Input data channel 1 ... 8
5	Input data	Input data channel 9 ... 16

The first four bytes of the input data have the same format for all Axioline E versions.

Bit 31 ... bit 6	Bit 5	Bit 4	Bit 3	Bit 2	Bit 1	Bit 0
Reserved	Supply of the module electronics and sensors (U _S)		Reserved			
Reserved	Undervoltage	Overload	Reserved			

Byte	Input process data															
	Byte 0								Byte 1							
Bit	7	6	5	4	3	2	1	0	7	6	5	4	3	2	1	0
IN	07	06	05	04	03	02	01	00	17	16	15	14	13	12	11	10
Connection	X04		X03		X02		X01		X08		X07		X06		X05	
Pin	2	4	2	4	2	4	2	4	2	4	2	4	2	4	2	4
DI	8	7	6	5	4	3	2	1	16	15	14	13	12	11	10	9

Key:

- Bit: Process data assignment
- IN: LED marking
- DI: Input of the device

13 Startup

13.1 Delivery state/default settings

By default upon delivery, the following functions and features are available:

IP settings

IP parameters:	0.0.0.0
Subnet mask:	0.0.0.0
Default Gateway:	0.0.0.0
BootP:	activated

Firmware update

Firmware update on next re-start:	deactivated
TFTP server IP address:	192.168.210.211
Firmware file name:	FIRMWARE.NXF

System identification

Device name:	No name assigned
Description:	No description assigned
Device location:	No location assigned
Contact:	No contact assigned

Web-based Management (WBM)

User name:	admin
Password:	private

13.2 Restoring the default settings

There are two options for resetting the default settings:

- Via web-based management, go to the Administration web page > default settings and follow the instructions.
- Via the rotary coding switch, switch position 0F

13.3 Starting the firmware

Once you have connected the power, the firmware is started.

After completion of the firmware boot process, the NET LED either lights up or flashes green.