



Chipsmall Limited consists of a professional team with an average of over 10 year of expertise in the distribution of electronic components. Based in Hongkong, we have already established firm and mutual-benefit business relationships with customers from,Europe,America and south Asia,supplying obsolete and hard-to-find components to meet their specific needs.

With the principle of “Quality Parts,Customers Priority,Honest Operation,and Considerate Service”,our business mainly focus on the distribution of electronic components. Line cards we deal with include Microchip,ALPS,ROHM,Xilinx,Pulse,ON,Everlight and Freescale. Main products comprise IC,Modules,Potentiometer,IC Socket,Relay,Connector.Our parts cover such applications as commercial,industrial, and automotives areas.

We are looking forward to setting up business relationship with you and hope to provide you with the best service and solution. Let us make a better world for our industry!



Contact us

Tel: +86-755-8981 8866 Fax: +86-755-8427 6832

Email & Skype: info@chipsmall.com Web: www.chipsmall.com

Address: A1208, Overseas Decoration Building, #122 Zhenhua RD., Futian, Shenzhen, China





Axioline F module with integrated safety logic and safe digital outputs

User manual

User manual

Axioline F module with integrated safety logic and safe digital outputs

2016-01-26

Designation: UM EN AXL F LPSDO8/3 1F

Revision: 00

This user manual is valid for:

Designation	HW/FW revision	Order No.
AXL F LPSDO8/3 1F	00/100	2702171

Please observe the following notes

User group of this manual

The use of products described in this manual is oriented exclusively to:

- Qualified electricians or persons instructed by them, who are familiar with applicable standards and other regulations regarding electrical engineering and, in particular, the relevant safety concepts.
- Qualified application programmers and software engineers, who are familiar with the safety concepts of automation technology and applicable standards.

Explanation of symbols used and signal words



This is the safety alert symbol. It is used to alert you to potential personal injury hazards. Obey all safety measures that follow this symbol to avoid possible injury or death.

There are three different categories of personal injury that are indicated with a signal word.

DANGER This indicates a hazardous situation which, if not avoided, will result in death or serious injury.

WARNING This indicates a hazardous situation which, if not avoided, could result in death or serious injury.

CAUTION This indicates a hazardous situation which, if not avoided, could result in minor or moderate injury.



This symbol together with the signal word **NOTE** and the accompanying text alert the reader to a situation which may cause damage or malfunction to the device, hardware/software, or surrounding property.



This symbol and the accompanying text provide the reader with additional information or refer to detailed sources of information.

How to contact us

Internet

Up-to-date information on Phoenix Contact products and our Terms and Conditions can be found on the Internet at:

phoenixcontact.com

Make sure you always use the latest documentation.

It can be downloaded at:

phoenixcontact.net/products

Subsidiaries

If there are any problems that cannot be solved using the documentation, please contact your Phoenix Contact subsidiary.

Subsidiary contact information is available at phoenixcontact.com.

Published by

PHOENIX CONTACT GmbH & Co. KG
Flachsmarktstraße 8
32825 Blomberg
GERMANY

Should you have any suggestions or recommendations for improvement of the contents and layout of our manuals, please send your comments to:

tecdoc@phoenixcontact.com

Please observe the following notes

General terms and conditions of use for technical documentation

Phoenix Contact reserves the right to alter, correct, and/or improve the technical documentation and the products described in the technical documentation at its own discretion and without giving prior notice, insofar as this is reasonable for the user. The same applies to any technical changes that serve the purpose of technical progress.

The receipt of technical documentation (in particular user documentation) does not constitute any further duty on the part of Phoenix Contact to furnish information on modifications to products and/or technical documentation. You are responsible to verify the suitability and intended use of the products in your specific application, in particular with regard to observing the applicable standards and regulations. All information made available in the technical data is supplied without any accompanying guarantee, whether expressly mentioned, implied or tacitly assumed.

In general, the provisions of the current standard Terms and Conditions of Phoenix Contact apply exclusively, in particular as concerns any warranty liability.

This manual, including all illustrations contained herein, is copyright protected. Any changes to the contents or the publication of extracts of this document is prohibited.

Phoenix Contact reserves the right to register its own intellectual property rights for the product identifications of Phoenix Contact products that are used here. Registration of such intellectual property rights by third parties is prohibited.

Other product identifications may be afforded legal protection, even where they may not be indicated as such.

Table of contents

1	For your safety	9
1.1	General safety notes.....	9
1.2	Electrical safety	10
1.3	Safety of the machine or system.....	11
1.4	Directives and standards	11
1.5	Intended use.....	11
1.6	Documentation	12
1.7	Abbreviations used	12
1.8	Safety hotline.....	12
2	Product description.....	13
2.1	Note about the system description	13
2.2	Short description of the module.....	13
2.3	Structure of the module	14
2.4	Housing dimensions	14
2.5	Safe digital outputs	15
2.6	Connection options for actuators depending on the parameterization	16
2.7	Local diagnostics and status indicators	17
2.8	Safe state	19
2.8.1	Operating state	19
2.8.2	Error detection in I/O devices	19
2.8.3	Device errors	20
2.8.4	Parameterization errors	20
2.9	Process data words	21
2.10	Programming data/configuration data.....	21
3	Integration of the Axioline F local bus	23
3.1	Supply voltage of the module logic	23
3.2	Supply voltage U_O	24
3.3	DC distribution network according to IEC 61326-3-1	25
3.4	Terminal point assignment.....	25
4	Assembly, removal, and electrical installation.....	27
4.1	Assembly and removal	27
4.1.1	Unpacking the module	27
4.1.2	Preparation and assembly	27
4.1.3	Setting the DIP switch	28
4.1.4	Mounting and removing the module	29

4.2	Electrical installation	31
4.2.1	Electrical installation of the Axioline F station	31
4.2.2	Electrical installation of the module	31
5	Parameterization of the module	33
5.1	Parameterization in a SafetyBridge system	33
5.2	Parameterization of the safe outputs	34
5.3	Behavior of the outputs in the event of enabled switch-off delay for stop category 1	35
6	Connection examples for safe outputs	37
6.1	Explanation of the examples	37
6.2	Notes on the protective circuit of external relays/contactors (freewheeling circuit)	39
6.3	Measures to achieve a specific safety integrity	39
6.4	Single-channel assignment of safe outputs	41
6.5	Two-channel assignment of safe outputs	43
7	Startup and validation	47
7.1	Initial startup	47
7.1.1	Startup mode	48
7.2	Restart after replacing a module	49
7.2.1	Replacing a module	49
7.2.2	Restart	49
7.3	Validation	49
8	Errors: messages and removal	51
8.1	Displaying and reading errors	51
8.2	Acknowledging an error	51
8.3	Module replacement following an error	51
8.4	Note about the error codes	52
8.5	Error codes	53
9	Maintenance, repair, decommissioning, and disposal	59
9.1	Maintenance	59
9.2	Repair	59
9.3	Decommissioning and disposal	59
10	Technical data and ordering data	61
10.1	SafetyBridge system data	61

10.2	AXL F LPSDO8/3 1F module data	61
10.3	Conformance with EMC Directive	65
10.4	Ordering data: module	66
10.5	Download data: software	66
10.6	Download data: documentation	66
A	Appendix: SafetyBridge system	67
A 1	Features and basic specifications of the system	67
A 2	System topology	69
A 2.1	General topology	69
A 2.2	Network and controller requirements	70
A 2.3	Safe input and output devices	70
A 2.4	Cross communication	71
A 3	SafetyBridge address assignment	76
A 4	SafetyBridge V3 system handling in various control systems	80
A 5	Feedback data	80
A 6	Enable principle	80
A 7	Diagnostics	83
A 7.1	Error detection in I/O devices	83
A 7.2	Detection of device errors	84
A 7.3	Acknowledgment of error messages for satellites	84
A 8	Configuration, parameterization, and download	85
A 8.1	Configuration and parameterization using the SAFECONF configuration software	85
A 8.2	Downloading the configuration and parameter data record	86
A 9	Safe state	86
A 10	Time response in the SafetyBridge system	87
A 10.1	Typical response time	87
A 10.2	Shutdown times	88
A 11	Achievable safety depending on the modules used	90
A 12	Behavior in the event of an error	90
A 12.1	Critical system or device errors	91
A 12.2	Parameterization or configuration errors	91
A 12.3	Communication errors	92
A 12.4	I/O errors	92
A 12.5	Application errors	92
A 13	Startup and restart	93
A 13.1	Startup/restart following power up	93
A 13.2	Restart after triggering a safety function	93
A 14	Memory sizes for the safety logic	94

B	Appendix: checklists	95
	B 1 Checklists for the SafetyBridge system	96
	B 1.1 Planning	96
	B 1.2 Configuration and parameterization	98
	B 1.3 Startup	99
	B 1.4 Safety functions	100
	B 1.5 Validation	101
	B 2 Checklists for the AXL F LPSDO8/3 1F module	102
	B 2.1 Planning	102
	B 2.2 Assembly and electrical installation	103
	B 2.3 Startup and parameterization	104
	B 2.4 Validation	105
C	Appendix: index	107
D	Appendix: revision history	109

1 For your safety

Purpose of this user manual

This user manual provides information about how the module works, its operating and connection elements, and its parameter settings.

Validity of the user manual

This user manual is valid for the AXL F LPSD08/3 1F module in the version indicated on the inner cover page, as well as for the same or later versions if replaced with devices of the same type.

1.1 General safety notes



WARNING: Risk of injury

Depending on the application, inappropriate use of the module may result in serious injury.

- Observe all the safety notes and warning instructions provided in this section and elsewhere in this user manual.

Qualified personnel

In terms of this user manual, qualified personnel are persons who, because of their education, experience and instruction, and their knowledge of relevant standards, regulations, accident prevention, and service conditions, have been authorized to carry out any required operations, and who are able to recognize and avoid any possible dangers.

Furthermore, knowledge of the following topics and products is required:

- Non-safety-related target system (e.g., PROFIBUS, PROFINET, EtherCAT®)
- SafetyBridge system
- Components used
- Axioline F product range
- Operation of the software tools
- Safety regulations in the field of application

In the context of the use of the system, the following operations must only be carried out by qualified personnel:

- Planning
- Configuration, parameterization, programming
- Installation, startup, servicing
- Maintenance, decommissioning

Documentation

Observe all information in this user manual and the accompanying documents: see Section 1.6 “Documentation” on page 12.

Safety of personnel and equipment

The safety of personnel and equipment can only be assured if the module is used correctly: see Section 1.5 “Intended use” on page 11.

Error detection

Depending on the wiring and the parameterization, the module detects errors within the safety equipment.

Do not carry out any repairs or modifications

It is prohibited for the user to carry out repair work or make modifications to the module. The housing must not be opened. The module is protected against tampering by means of security labels. The security label is damaged in the event of unauthorized repairs or opening of the housing. In this case, the correct operation of the safety module can no longer be ensured.

In the event of an error, send the module to Phoenix Contact or contact Phoenix Contact immediately and engage a service engineer.

Mismatching and polarity reversal of connections

Take care to avoid the mismatching, polarity reversal or tampering of connections. For increased protection against mismatching, connectors and slot markings are color coded.

1.2 Electrical safety



WARNING: Loss of safety function/hazardous shock currents
 Incorrect installation can result in the loss of the safety function as well as hazardous shock currents.

- Observe the notes on electrical safety.
- Plan the modules used and their installation in the system according to the specific requirements.
- Recheck plants and systems retrofitted with SafetyBridge.

Direct/indirect contact

Protection against direct and indirect contact according to VDE 0100 Part 410 must be ensured for all components connected to the system. In the event of an error, parasitic voltages must not occur (single-fault tolerance).

Measures required:

- Using power supply units with safe isolation (PELV).
- Decoupling circuits, which are not PELV systems, using optocouplers, relays, and other components which meet the requirements of safe isolation.

Power supply units for 24 V supply

Only use power supply units with safe isolation and PELV according to EN 50178/VDE 0160 (PELV). These power supply units prevent short circuits between the primary and secondary side.

Make sure that the output voltage of the power supply does not exceed 32 V even in the event of an error.

Insulation rating

When selecting the equipment, please take into consideration the dirt and surge voltages which may occur during operation.

The module is designed for overvoltage category II (according to DIN EN 60664-1). If you expect surge voltages in the system, which exceed the values defined in overvoltage category II, implement additional measures for voltage limitation.

1.3 Safety of the machine or system

The machine/system manufacturer and the operator are responsible for the safety of the machine or system and the application in which the machine or system is used.

Draw up and implement a safety concept

In order to use the module, a safety concept is required for your machine or system. This includes a hazard and risk analysis as well as a test report (checklist) for validating the safety function: see Section 1.4 “Directives and standards” on page 11, see Section B “Appendix: checklists” on page 95.

The target safety integrity (SIL according to IEC 61508, SILCL according to EN 62061 or performance level and category according to EN ISO 13849-1) is ascertained on the basis of the risk analysis. The safety integrity ascertained determines how to connect and parameterize the module within the safety function.

Validate hardware and parameterization

Carry out a validation every time you make a safety-related modification to your overall system.

Use your test report to ensure that:

- The safe modules are connected to the correct sensors and actuators
- The safe input and output channels have been parameterized correctly
- The variables have been linked to the safe sensors and actuators (single-channel or two-channel) correctly

1.4 Directives and standards

The standards to which the module conforms are listed in the certificate issued by the approval body and in the EC declaration of conformity (see: phoenixcontact.net/products).

1.5 Intended use

The AXL F LPSDO8/3 1F module is designed exclusively for use in a SafetyBridge system. It can only perform its tasks in the system if it is used according to the specifications in this document.

Only use the module according to the defined technical data and ambient conditions: see Section 10 “Technical data and ordering data” on page 61.

The module is designed for connecting single-channel or two-channel actuators, which can be used in association with safety technology.

Examples of use for the module:

- Safety circuits according to EN 60204 Part 1
- Safe shutdown of contactors, motors (24 V DC), valves, ohmic, inductive, and capacitive loads

The module is **not** suitable for applications in which stop category 1 also has to be observed in the event of an error.

1.6 Documentation

Currentness and availability of documentation

Always use the latest documentation. Changes or additions to documentation can be found on the Internet (see: phoenixcontact.net/products).

SafetyBridge user manuals

User manuals:

- For the controller used
- For the SafetyBridge system I/O modules used
- For the SafetyBridge system function blocks

Please also observe the information on the bus system used.

Documentation for the Axioline F product range

Axioline F: system and installation user manual, UM EN AXL F SYS INST
 Documentation for the bus coupler used

1.7 Abbreviations used

Table 1-1 Abbreviations for safety requirements

Abbreviation	Meaning	Standard	Example
SIL	Safety integrity level	IEC 61508	SIL 2, SIL 3
SILCL	SIL claim limit	EN 62061	SILCL 3
Cat.	Category	EN ISO 13849-1	Cat. 2, Cat. 4
PL	Performance level	EN ISO 13849-1	PL e, PL d

Table 1-2 General abbreviations

Abbreviation	Meaning
PELV	Protective extra-low voltage according to EN 50178/VDE 0160
EUC	Equipment under control

1.8 Safety hotline

Should you have any technical questions, please contact our 24-hour hotline.

Phone: + 49 5281 9-46277, e-mail: safety-service@phoenixcontact.com

2 Product description

2.1 Note about the system description

The SafetyBridge system is described in “Appendix: SafetyBridge system” on page 79.

In the description of the safety module (UM EN AXL F LPSDO8/3 1F), it is assumed that you are familiar with the SafetyBridge system. If this is not the case, please refer to Appendix A first for information on the system.

2.2 Short description of the module

The AXL F LPSDO8/3 1F module is an output module with integrated safety logic for use at any point in an Axioline F station.

The module is designed for use in the SafetyBridge system. The SafetyBridge address is set via a DIP switch.

The module has four safe positive switching digital outputs for two-channel assignment or eight safe positive switching digital outputs for single-channel assignment.

The outputs can be parameterized according to the specific application and enable the integration of actuators in the safe SafetyBridge system.

In the SafetyBridge system, the module can be used to achieve safety functions with the following requirements depending on the operating conditions:

- Up to SIL 3 according to IEC 61508
- Up to SILCL 3 according to EN 62061
- Up to Cat. 4/PL e according to EN ISO 13849-1

2.3 Structure of the module

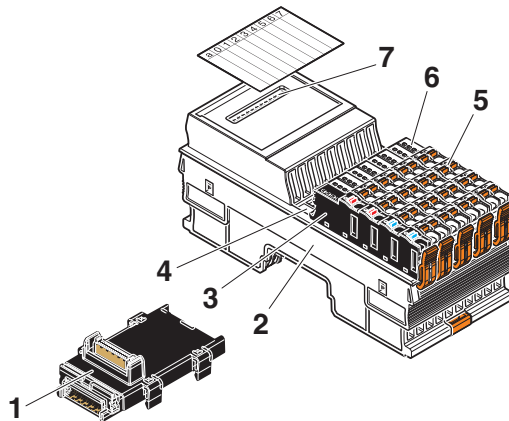

Figure 2-1 Structure of the module

- 1 Bus base module
- 2 Electronics module
- 3 Connector for connecting the supply voltage
- 4 Function identification
- 5 I/O connector
- 6 Diagnostics and status indicators
- 7 DIP switch



More detailed information on setting the switch: see Section 4.1.3 “Setting the DIP switch” on page 28.

2.4 Housing dimensions

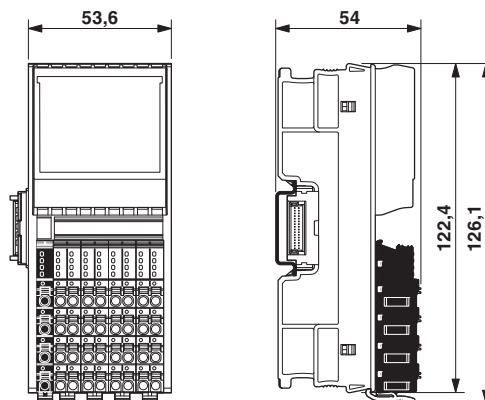

Figure 2-2 Housing dimensions (in mm)

2.5 Safe digital outputs

The module has safe digital outputs which can be used as follows:

- For two-channel assignment: four two-channel outputs
- For single-channel assignment: eight single-channel outputs

Technical data for the safe outputs: “Safe digital outputs” on page 63.

Parameterization

The safe digital outputs of a module can be parameterized in pairs. This means that the outputs can be adapted to various operating conditions and different safety integrity levels can be implemented (SIL, SILCL, Cat., PL).

In order to achieve a high level of error detection, the test pulses must be enabled. If this is not possible for the connected loads, the test pulses can be disabled, however, error detection is then reduced.



The safety integrity (SIL, SILCL, Cat., PL) and error detection that can be achieved depend on the parameterization, the structure of the actuator, and the cable installation: see Section 6 “Connection examples for safe outputs” on page 37.

Information on the parameterization of the outputs: see Section 5.2 “Parameterization of the safe outputs” on page 34.

Diagnostics

Diagnostics are provided via both the local diagnostics indicators and the diagnostic messages which are transmitted to the controller.

Information on the diagnostic messages of the outputs: see Section 8 “Errors: messages and removal” on page 51.



WARNING: Loss of safety function

Using diagnostic data for safety-related functions can result in the loss of the safety function as diagnostic data is not safety-related.

- Do not use the diagnostic data for safety-related functions or actions.

Requirements for actuators/controlled devices

Functional safety places requirements on the design of actuators/controlled devices.

- Use suitable actuators/controlled devices which are described in the applicable safety standards, for example.

The module's ability to detect errors depends on the parameterization.

- Adapt the module parameterization to the relevant actuator/controlled device: see Section 5 “Parameterization of the module” on page 33.

If the outputs are parameterized with test pulses, the output circuits are tested by test pulses at regular intervals. These test pulses are visible at the output and can trigger undesirable reactions with quick responding actuators. The test pulses are either light pulses (brief activation) which can be disabled or dark pulses (brief deactivation) which cannot be disabled.



WARNING: Unintentional machine startup
 Reactions from test pulses can cause unintentional machine startup.

- If the process does not tolerate this behavior, the following measures must be taken:
 - Use actuators with sufficient inertia.
 - Make sure that the load is not so dynamic that it causes hazardous states within 1 ms.

Quick actuators which offer a safety-related response to pulses in under 1 ms are not generally permitted.

Disabling the test pulses affects the error detection of the module.

- Observe the achievable safety integrity: see Section 6 “Connection examples for safe outputs” on page 37.
- Observe the notes on the safe assignment of outputs: see Section 6.4 “Single-channel assignment of safe outputs” on page 41, see Section 6.5 “Two-channel assignment of safe outputs” on page 43.

2.6 Connection options for actuators depending on the parameterization

Actuators that meet various safety requirements depending on the parameterization can be connected to the outputs.

The maximum achievable SIL/SILCL/Cat./PL is specified in the table.

In order to meet the safety requirements:

- Observe the information in the connection examples: see Section 6 “Connection examples for safe outputs” on page 37.
- Observe the requirements of the standards with regard to the external wiring and the actuators to be used to achieve a SIL/SILCL/Cat./PL: see Section 6.3 “Measures to achieve a specific safety integrity” on page 39.

“Output” parameterization	Output OUT0 to OUT3	
	Single-channel	Two-channel
Test pulses	Any	On/off*
Achievable safety integrity	SIL 2/SILCL 2/Cat. 3/PL d	SIL 3/SILCL 3/Cat. 4/PL e
For connection example, see page	41	43

* If the test pulses are disabled, a cross-circuit between the outputs is only detected if the output is enabled.



To achieve Cat. 3, two-channel actuators are usually used.

2.7 Local diagnostics and status indicators

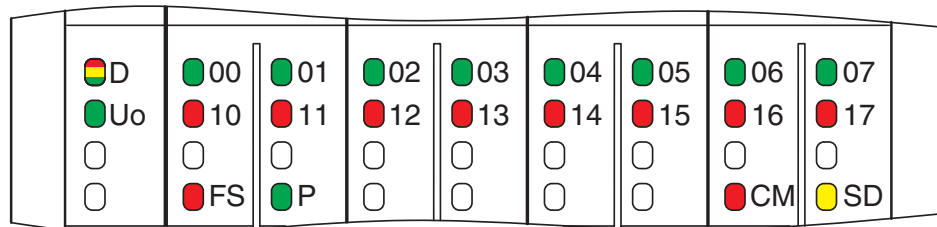

Figure 2-3 Local diagnostics and status indicators

Table 2-1 Overview of diagnostics LEDs

Des.	Color	State	Description
D	Red/yellow/green	Diagnostics for local bus communication	
		Green on	The device is ready for operation, communication within the station is OK. All data is valid. There is no error.
		Flashing green	The device is ready for operation, communication within the station is OK. The data is not valid. Valid data from the controller/higher-level network not available. There is no error on the module.
		Flashing green/yellow	The device is ready for operation, communication within the station is OK. Output data cannot be output and/or input data cannot be read. There is an error on the I/O side of the module.
		Yellow on	The device is ready for operation, but has still not detected a valid cycle after power on.
		Flashing yellow	The device is not (yet) part of the active configuration.
		Red on	The device is ready for operation, but has lost the connection to the bus head.
		Flashing red	The device is ready for operation, but there is no connection to the previous device.
		Off	Device is in (power) reset.
UO	Green	Diagnostics for digital output supply	
		Green on	Supply for the digital outputs is present and is > around 17 V DC.
		Flashing green	Supply for the digital outputs is not present or is < around 17 V DC.
FS	Red	Diagnostics for failure state	
		Off	The safety application has a valid parameterization. (Only applies if UI is on or flashing at the same time.)
		Red on	Hardware fault. Communication to the higher-level controller is disabled. The module has entered the safe state (failure state).
		Flashing red	The module is not parameterized.

Des.	Color	State	Description
P	Green	Diagnostics for safe communication protocol	
		Off	The module is not parameterized.
		Green on	The module is parameterized. Safe communication is running without errors at all satellites (if present).
		Flashing green	The module is parameterized. Error in safe communication at at least one satellite.
CM	Red	Startup mode	
		Off	SafetyBridge mode.
		Red on	Startup mode. ⚠ WARNING: In startup mode, the device is in standard operation. Startup mode: see Section 7.1.1 “Startup mode” on page 48.
SD	Yellow	Acknowledgment request	
		Off	No diagnostic message present that needs to be acknowledged.
		Yellow on	A diagnostic message is present that needs to be acknowledged for safe digital output errors, supply voltage errors or general errors. Acknowledgment: see Section 8.2 “Acknowledging an error” on page 51.
00 - 07	Green	Status of each output from 0 - 7	
		Off	Output at logic “0”.
		Green on	Output at logic “1”.
10 - 17	Red	Diagnostics for each output from 0 - 7	
		Off	No error present at the output.
		Red on	Error at the output (e.g., short circuit).

2.8 Safe state

The safe state for the module is the no load state at the local output terminal blocks: see Section 2.5 “Safe digital outputs” on page 15.

The logic module forwards the safe state to all output satellites.

The safe state can be entered in the following cases:

1. Operating state
2. Error detection in I/O devices
3. Device errors
4. Parameterization errors
5. Error detection during safe communication

2.8.1 Operating state

In the operating state, the outputs can enter states “1” or “0”. State “0” is the safe state.

2.8.2 Error detection in I/O devices

If an error is detected at an output, this output is disabled (“0” = safe state).

Outputs

Operating time in the error state



WARNING: Loss of the safe state in the failure state

In the failure state, internal module tests are no longer run and it is possible that the safe state may be exited due to an accumulation of errors.

- If the module enters an error state, assess, acknowledge or remove the error within 72 hours.

Depending on the parameterization, the following errors can be detected at outputs:

- Short circuit
- Cross-circuit
- Overload

The diagnostic message is transmitted to the controller: see Section 8 “Errors: messages and removal” on page 51. Information on which errors are detected and when: see Section 6 “Connection examples for safe outputs” on page 37.



If an error occurs on a channel of an output parameterized as “two-channel”, the other corresponding channel also enters the safe state.

2.8.3 Device errors

Outputs

If a hardware fault in the internal circuit is detected at an output, **all** module outputs are disabled ("0" = off = safe state).

The diagnostic message is transmitted to the controller: see Section 8 "Errors: messages and removal" on page 51.

**Failure state:
serious errors**

Serious errors that can result in the loss of or adversely affect the safety function cause the entire module to enter the safe state. The FS LED on the module is permanently on. The failure state can only be exited by means of a power up.

The following serious errors result in the safe state:

- Serious hardware faults in the internal circuit
- User errors
- Module overload
- Module overheating

The diagnostic message is transmitted to the controller: see Section 8 "Errors: messages and removal" on page 51.



WARNING: Loss of safety function

Sequential errors can result in the loss of the safety function.

- In the event of a device error, the module should be completely disconnected from the power supply and replaced so as to prevent sequential errors.

2.8.4 Parameterization errors

The module switches to the safe state following parameterization errors. The FS LED on the module flashes.

In the event of faulty parameterization, a diagnostic message is transmitted to the controller: see Section 8 "Errors: messages and removal" on page 51.

2.9 Process data words

The module occupies 24 words in the Axioline F system.



Access the process data words via the “Operate” function block.

The module has feedback data and enable data. See Section A 5, “Feedback data” and “Enable principle” on page 80.

2.10 Programming data/configuration data

Phoenix Contact provides device description files for various control systems.



The programming data/configuration data is defined in the device description (FDCML, GSD, GSDML, etc.) according to the bus or network used.

3 Integration of the Axioline F local bus

The module is integrated for operation in an Axioline F station.



More detailed information on the structure of an Axioline F station: see UM EN AXL F SYS INST user manual.

3.1 Supply voltage of the module logic

The supply voltage for the module logic is generated in the bus coupler and led to the Axioline F module via the bus base module.



WARNING: Loss of safety function

The use of unsuitable power supplies can result in the loss of the safety function.

- Only use power supplies according to EN 50178/VDE 0160 (PELV) for the voltage supply at the bus coupler.
- Observe the general safety notes: see Section 1.2 “Electrical safety” on page 10.

Technical data for the supply voltage: see “Supply voltage U_{BUS} (logic)” on page 63.

The current carrying capacity for supply voltage U_{BUS} depends on the bus coupler used.

- Observe the technical data and information in the documentation for the bus coupler.

3.2 Supply voltage U_O



WARNING: Loss of safety function

The use of unsuitable power supplies can result in the loss of the safety function.

- Observe the general safety notes: see Section 1.2 “Electrical safety” on page 10.



WARNING: Loss of safety function

Parasitic voltages can result in the loss of the safety function.

- Supply supply voltage U_{BUS} and supply voltage U_O at the bus coupler from the same power supply unit so that the module loads are not affected by parasitic voltages in the event of an error.

Supply voltage U_O supplies the output circuits. Technical data for supply voltage U_O : see “Supply voltage U_O (actuators)” on page 63.

The maximum current carrying capacity for the main circuit U_O is 8 A.



NOTE: Module damage

Parallel protection against polarity reversal is only implemented in the device for a limited period. The following measures must be taken to prevent damage to the module:

- Due to the maximum current carrying capacity of 8 A, protect supply voltage U_O externally with an 8 AT fuse.
- Only use PELV power supply units with at least four times the nominal tripping current, as this is the only way to ensure tripping times of less than 300 ms.

Supply voltage U_O should feature a connection to functional earth ground according to EN 60204-1.

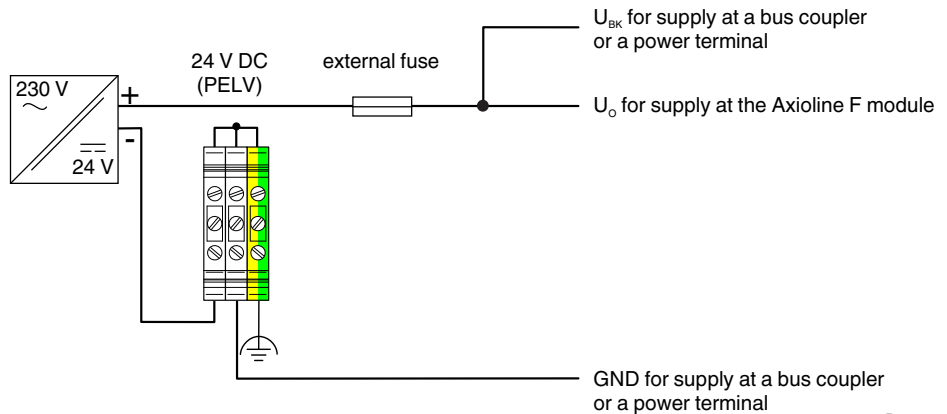

105739B000_en

Figure 3-1 Supply voltage U_O with connection to functional earth ground according to EN 60204-1

Observe the information regarding the behavior of the module in the event of an error at supply voltage U_O : see Section 8 “Errors: messages and removal” on page 51.

3.3 DC distribution network according to IEC 61326-3-1



NOTE: Damage to module electronics

A surge voltage will damage the module electronics.

- Do not use a DC distribution network.

A DC distribution network is a DC power supply network which supplies a complete industrial hall with DC voltage and to which any device is connected. A typical system or machine distribution is not a DC distribution network. For devices that are intended for a typical system or machine distribution, the DC connections are viewed and tested as I/O signals according to IEC 61326-3-1.

3.4 Terminal point assignment

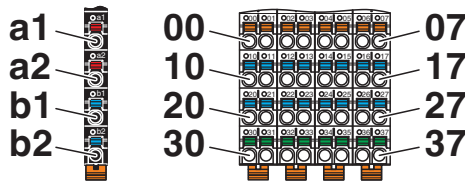

Figure 3-2 Terminal point assignment

The Axioline F connectors are supplied with the module. They are color coded and marked for connection.



Only use the connectors supplied with the module.

The following applies for the tables below:

- All outputs are safe digital outputs
- 0 V (GND): common ground of outputs
- FE: common functional earth ground

Table 3-1 Terminal point assignment of the voltage connection

Terminal point	Color	Assignment	
a1, a2	Red	24 V DC (UO)	UO: supply of the digital outputs (internally connected)
b1, b2	Blue	GND	Reference potential of the supply voltage (internally connected)