



Chipsmall Limited consists of a professional team with an average of over 10 year of expertise in the distribution of electronic components. Based in Hongkong, we have already established firm and mutual-benefit business relationships with customers from,Europe,America and south Asia,supplying obsolete and hard-to-find components to meet their specific needs.

With the principle of “Quality Parts,Customers Priority,Honest Operation,and Considerate Service”,our business mainly focus on the distribution of electronic components. Line cards we deal with include Microchip,ALPS,ROHM,Xilinx,Pulse,ON,Everlight and Freescale. Main products comprise IC,Modules,Potentiometer,IC Socket,Relay,Connector.Our parts cover such applications as commercial,industrial, and automotives areas.

We are looking forward to setting up business relationship with you and hope to provide you with the best service and solution. Let us make a better world for our industry!



Contact us

Tel: +86-755-8981 8866 Fax: +86-755-8427 6832

Email & Skype: info@chipsmall.com Web: www.chipsmall.com

Address: A1208, Overseas Decoration Building, #122 Zhenhua RD., Futian, Shenzhen, China



BAR-ANT-N-N-EX

Antenna barrier for the hazardous area

Data sheet
106403_en_00

© PHOENIX CONTACT 2015-06-30



1 Description

Using an antenna barrier, you can execute HF outputs of wireless modules with intrinsic safety. The antenna barrier limits the ignition energy in the event of an error.

You can connect selected standard antennas from the range of accessories from Phoenix Contact.

Features

- Coax connection with N connectors
- For earthbound transceiver systems
- International approvals (ATEX, IECEx)
- Installation in zone 2 or in the safe area
- Frequency range 0.7 GHz ... 6 GHz
- Cost-effective use of selected standard antennas in zones 0, 1 and 2
- Easy and space-saving installation, wide variety of mounting options inside or outside the control cabinet



WARNING: Explosion hazard when used in potentially explosive areas

Follow the instructions described here during installation and observe the safety notes at all times!



Make sure you always use the latest documentation.

It can be downloaded from the product at phoenixcontact.net/products.

2	Table of contents	
1	Description	1
2	Table of contents	2
3	Ordering data	3
4	Technical data	4
5	Structure	5
	5.1 Mounting options	5
6	Safety notes.....	6
	6.1 Installation notes	6
	6.2 Intrinsic safety.....	6
	6.3 Installation in Zone 2.....	6
7	Example: installing the antenna barrier in zone 1	7
8	Example: installing the antenna barrier in zone 2.....	8
9	Installation in potentially explosive area.....	9
	9.1 Installation in zone 2	9
	9.2 Installation in zone 1	9
	9.3 Installing the devices in zone 2 and the antennas in zone 1 or zone 0.....	9
	9.4 Installing the devices in zone 1 and the antennas in zone 0	9

3 Ordering data

Description	Type	Order No.	Pcs./Pkt.
Antenna barrier for installation in Ex zone 2, separates and transmits HF signals with intrinsic safety (Ex i) to an antenna in zone 0, 1 or 2, 0.7 GHz ... 6 GHz frequency range, N (female) -> N (female), ATEX & IECEx approval	BAR-ANT-N-N-EX	2702198	1
Accessories	Type	Order No.	Pcs./Pkt.
Omnidirectional antenna, 868 MHz, 4 dBi, linear vertical, N (female), opening angle h/v 360°/30°, IP67, salt water resistant, incl. mounting bracket and mast clips for 30 mm ... 45 mm diameter, stainless steel, ATEX & IECEx approval	ANT-OMNI-868-01	2702136	1
Omnidirectional antenna, 2.4 GHz, 6 dBi, linear vertical, opening angle h/v 360°/30°, N (female), IP55, incl. mounting bracket and mast clips for 45 mm - 100 mm diameter, stainless steel, ATEX & IECEx approval	RAD-ISM-2400-ANT-OMNI-6-0	2885919	1
Panel antenna, 868 MHz, 3.5 dBi, circular polarized, N (female), IP67, incl. mounting bracket and mast clips for 25 mm ... 85 mm diameter, stainless steel, ATEX & IECEx approval	ANT-DIR-868-01	2702137	1
Panel antenna, 2.4/5 GHz, 9 dBi, linear vertical, N (female), IP67, incl. mounting bracket and mast clips for 25 mm - 85 mm diameter, stainless steel, ATEX & IECEx approval	ANT-DIR-2459-01	2701186	1
Antenna cable, 0.5 m in length; N (male) -> RSMA (male), 50 Ω impedance	RAD-PIG-RSMA/N-0.5	2903263	1
Antenna cable, 1 m in length; N (male) -> RSMA (male), 50 Ω impedance	RAD-PIG-RSMA/N-1	2903264	1
Antenna cable, 2 m in length; N (male) -> RSMA (male), 50 Ω impedance	RAD-PIG-RSMA/N-2	2903265	1
Antenna cable, 3 m in length; N (male) -> RSMA (male), 50 Ω impedance	RAD-PIG-RSMA/N-3	2903266	1
Antenna cable, 5 m in length; N (male) -> RSMA (male), 50 Ω impedance	RAD-PIG-RSMA/N-5	2702140	1
Antenna cable, 3 m in length, N (male) -> N (male), 50 Ω impedance	RAD-CAB-EF393- 3M	2867649	1
Antenna cable, 5 m in length, N (male) -> N (male), 50 Ω impedance	RAD-CAB-EF393- 5M	2867652	1
Antenna cable, 10 m in length, N (male) -> N (male), 50 Ω impedance	RAD-CAB-EF393-10M	2867665	1
Antenna extension cable, 15 m in length, N (male) -> N (male), 50 Ω impedance	RAD-CAB-EF393-15M	2885634	1
2400 MHz wireless transceiver with RS-232, RS-485 2-wire interface, expandable with I/O extension modules, with screw connection, antenna connection: RSMA (female), including DIN rail connector, without antenna	RAD-2400-IFS	2901541	1
868 MHz wireless transceiver with RS-232, RS-485 2-wire interface, expandable with I/O extension modules, with screw connection, antenna connection: RSMA (female), including DIN rail connector, without antenna.	RAD-868-IFS	2904909	1
Vulcanizing sealing tape for external protection of adapters, cable connections, etc. against the effects of weather, roll length: 3 m	RAD-TAPE-SV-19-3	2903182	1
Angled bracket for individually fixing CN-UB... to housing panels, for example.	CN-UB/MP-90DEG-50	2803137	10
Primary-switched power supply MINI POWER for DIN rail mounting, input: 1-phase, output: 24 V DC/1,5 A, for the potentially explosive area	MINI-PS-100-240AC/24DC/1.5/EX	2866653	1

4 Technical data

Electrical data

Frequency range	700 MHz ... 6000 MHz
Maximum HF output power P_i	2 W
Maximum error voltage U_m	253 V AC/DC
Insulation voltage input/output	375 V AC/DC
Impedance	50 Ω
Attenuation	< 1.2 dB (868 MHz) < 0.9 dB (900 MHz) < 0.2 dB (2.4 GHz) < 0.5 dB (5.2 GHz) < 1.8 dB (5.8 GHz)
Test voltage	2.1 kV AC (50 Hz / 2 s)
Maximum capacity	5.64 nF

General data

Degree of protection	IP65
Connection method	N (female)
Housing material	Nickel-plated brass
Dimensions (W/H/D)	25 mm x 25 mm x 68.8 mm

Ambient conditions

Ambient temperature (operation)	-40 °C ... 75 °C
Ambient temperature (storage/transport)	-40 °C ... 85 °C

Approvals / Certificates

Conformance	CE-compliant
IECEX	[Ex ia Ma] I [Ex ia Ga] IIC [Ex ia Da] IIIC Ex nA [ia Ga] IIC T6 Gc X
ATEX Please follow the special installation instructions in the documentation!	Ⓔ I (M1) [Ex ia Ma] I Ⓔ II (1) G [Ex ia Ga] IIC Ⓔ II (1) D [Ex ia Da] IIIC Ⓔ II 3 (1) G Ex nA [ia Ga] IIC T6 Gc X

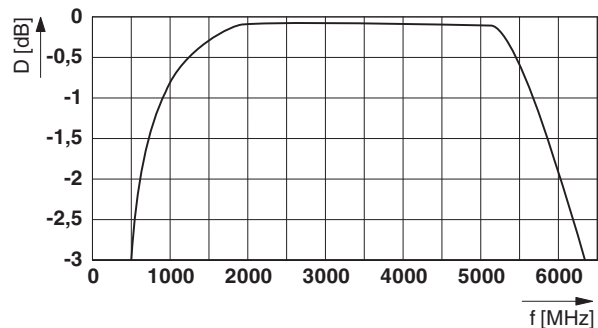

Figure 1 Attenuation

5 Structure

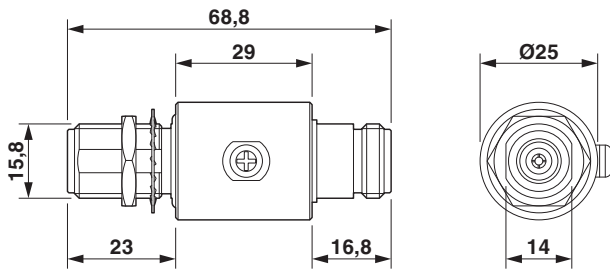

Figure 2 Dimensions

5.1 Mounting options

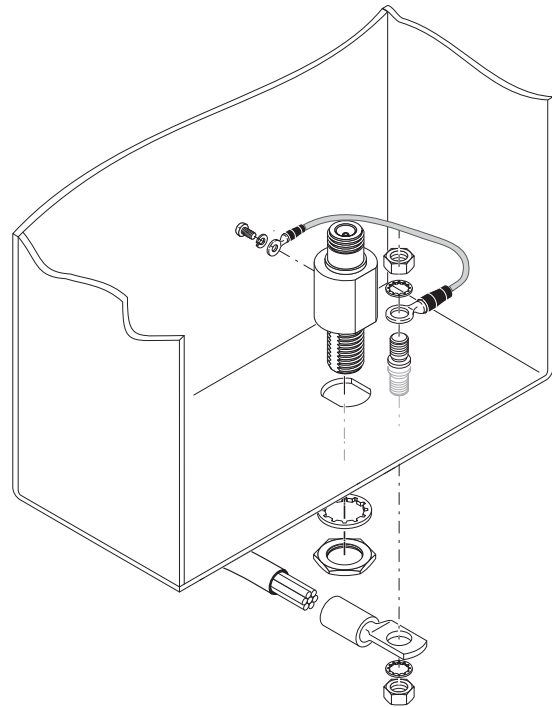

Figure 3 Control cabinet feed-through

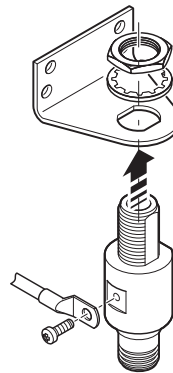

Figure 4 Mounting plate



Using the CN-UB mounting plate, which is available as an accessory, you can securely mount the antenna barrier, e. g. in the switch cabinet.

6 Safety notes



WARNING: Explosion hazard when used in potentially explosive areas

Please make sure that the following notes and instructions are observed.

6.1 Installation notes

- The device is a piece of equipment (category 1) which belongs to the "Intrinsic Safety" ignition protection class and can be installed in Ex zone 2 as a category 3 device. It meets the requirements of EN 60079-0:2012, EN 60079-11:2012, EN 60079-15:2010, IEC 60079-0 ed. 6.0, IEC 60079-11 ed. 6.0, and IEC 60079-15 ed. 4.0.
- Installation, operation, and maintenance may only be carried out by qualified electricians. Follow the installation instructions as described. When installing and operating the device, the applicable regulations and safety directives (including national safety directives), as well as general technical regulations, must be observed. For the safety technology data, see this packing slip and the certificates (EC examination certificate and other approvals if appropriate).
- The device must not be opened or modified. Do not repair the device yourself, replace it with an equivalent device. Repairs may only be carried out by the manufacturer. The manufacturer is not liable for damage resulting from violation.
- The device must be stopped and immediately removed from the Ex area if it is damaged, was subject to an impermissible load, stored incorrectly or if it malfunctions.
- Do not subject the device to mechanical and/or thermal loads that exceed the specified limits.
- The device is not designed for use in atmospheres with a danger of dust explosions.
- When using the antenna in a non-intrinsically safe circuit, the Ex markings should be obscured. The device can then no longer be operated in intrinsically safe circuits.
- Observe the specified conditions for use in potentially explosive areas! Install the device in a suitable approved housing (with a minimum of IP54 protection) that meets the requirements of EN 60079-15. Observe the requirements of EN 60079-14.
- Connection to the intrinsically safe circuit in areas with a danger of dust explosions (zone 20, 21 or 22) is only permitted if the equipment connected to this circuit is approved for this zone (e.g., category 1D, 2D or 3D).

6.2 Intrinsic safety

- The device may only be operated when the specified atmospheric conditions are met.
- Check the safety technology data of the power supply device and the antenna and ensure intrinsic safety. The technical data can be found in this package insert and in the approval documents and certificates. Only use devices approved for intrinsically safe circuits.
- Ground metallic parts or attachments on the antenna barrier and the antenna.
- The antenna barrier's input power must not exceed $P_i = 2 \text{ W}$; the approved maximum input voltage is $U_m = 253 \text{ V AC}$.

6.3 Installation in Zone 2

- Only devices which are designed for operation in Ex zone 2 and are suitable for the conditions at the installation location may be connected to the circuits in the Ex zone.
- In potentially explosive areas, it is only permitted to disconnect cables when the power is disconnected. Intrinsically safe cables are an exception.

7 Example: installing the antenna barrier in zone 1



WARNING: Explosion hazard when used in potentially explosive areas

- Observe the specified conditions for use in potentially explosive areas.
- When installing and connecting the supply and signal circuits observe the requirements of EN/IEC 60079-14.
- Access to circuits within the device is not permitted.
- Do not repair the device yourself; replace it with an equivalent device instead. Repairs may only be carried out by the manufacturer.
- The device must be stopped and immediately removed from the Ex area if it is damaged, has been subjected to an impermissible load, has been stored incorrectly, or if it malfunctions.



WARNING: Explosion hazard when used in potentially explosive areas

Install the antenna barrier directly in front of the device which requires protection.

Installation in a housing with “flameproof enclosure” type of protection (EN 60079-1)

- Feed the adapter cable of the antenna barrier through the opening provided in the Ex housing.
- Mount the antenna barrier in the control cabinet with the CN-UB mounting plate (Order No. 2803137).
- Connect the adapter cable (5) directly to the wireless module (4).
- Connect the ground connection (screw) via the shortest possible route to the local equipotential bonding using a suitable cable.
- Cut the leads to the required length.
- Do not lay protected and unprotected lines immediately parallel to one another. Potential equalization cables are also considered unprotected cables.
- Connect the antenna barrier to the antenna (8) using an antenna cable (7). Install the antenna cable so that it is fixed in place and screw it in securely at both ends so as to prevent accidental disconnection of the antenna cable.



If the connector is subject to too high tensile and bending forces, the HF cable must be secured.

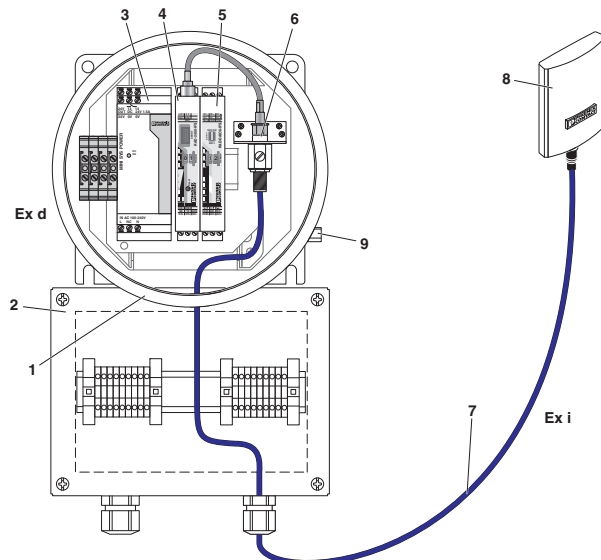

Figure 5 Installation in a housing with “flameproof enclosure” type of protection (EN 60079-1)

Key:

- 1 Flameproof Ex d housing
- 2 Ex e wiring space
- 3 230 V AC/24 V DC power supply, MINI-PS-240AC/24DC/1.5/EX, Order No. 2866653
- 4 Wireless module
- 5 Adapter cable
- 6 Antenna barrier
- 7 Antenna cable
- 8 Antenna
- 9 Connection for equipotential bonding system

8 Example: installing the antenna barrier in zone 2



WARNING: Explosion hazard when used in potentially explosive areas

- Observe the specified conditions for use in potentially explosive areas.
- Install the device in a suitable approved housing (with at least IP54 degree of protection) that meets the requirements of EN 60079-15. Observe the requirements of EN 60079-14.
- In zone 2, only connect devices to the supply and signal circuits that are suitable for operation in potentially explosive areas of zone 2 and the conditions at the installation location.
- Access to circuits within the device is not permitted.
- Do not repair the device yourself; replace it with an equivalent device instead. Repairs may only be carried out by the manufacturer.
- The device must be stopped and immediately removed from the Ex area if it is damaged, has been subjected to an impermissible load, has been stored incorrectly, or if it malfunctions.



WARNING: Explosion hazard when used in potentially explosive areas

Install the antenna barrier directly in front of the device which requires protection.

Installation in a housing approved for zone 2

- The bore hole in the switch cabinet must have a diameter of 15.9 mm ... 16.3 mm. The maximum diameter of the 16.3 millimeters must not be exceeded!
- Feed the adapter cable of the antenna barrier through the opening provided in the housing.
- Screw the antenna barrier (5) to the housing.
- Connect the adapter cable (4) directly to the wireless module (3).
- Connect the ground connection (screw) via the shortest possible route to the local equipotential bonding using a suitable cable.
- Cut the leads to the required length.
- Do not lay protected and unprotected lines immediately parallel to one another. Potential equalization cables are also considered unprotected cables.

- Connect the antenna barrier to the antenna (7) using an antenna cable (6). Install the antenna cable so that it is fixed in place and screw it in securely at both ends so as to prevent accidental disconnection of the antenna cable.
- Tighten all screw connections with 0.4 Nm.



If the connector is subject to too high tensile and bending forces, the HF cable must be secured.

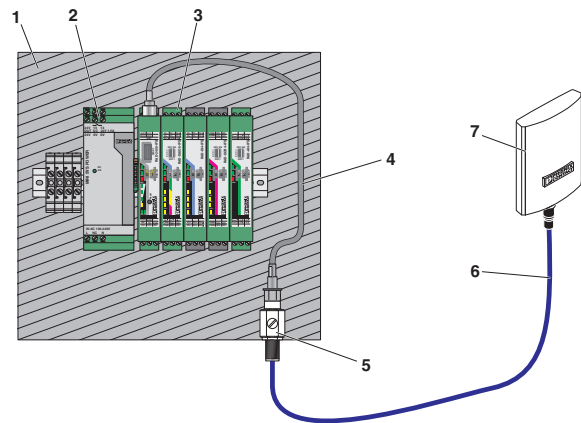

Key:

- 1 Housing that meets the requirements of EN 60079-0 and EN 60079-15 and at least IP54 (EN 60529) degree of protection
- 2 Power supply
- 3 Wireless module and I/O extension modules
- 4 Adapter cable
- 5 Antenna barrier
- 6 Antenna cable
- 7 Antenna

9 Installation in potentially explosive area

9.1 Installation in zone 2

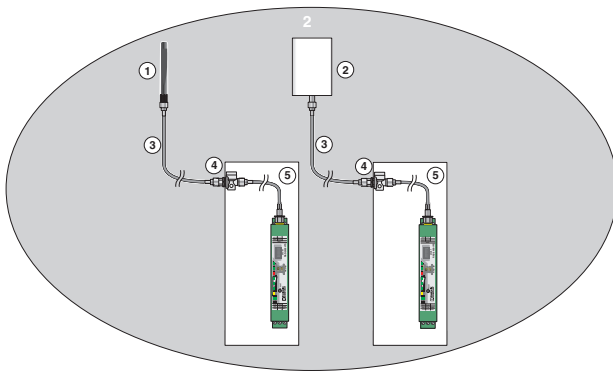

Figure 6 Installing the devices and antennas in zone 2

Key:

- 1 Omnidirectional antenna
- 2 Directional antenna
- 3 Antenna cable
- 4 Antenna barrier
- 5 Adapter cable to the wireless module

9.2 Installation in zone 1

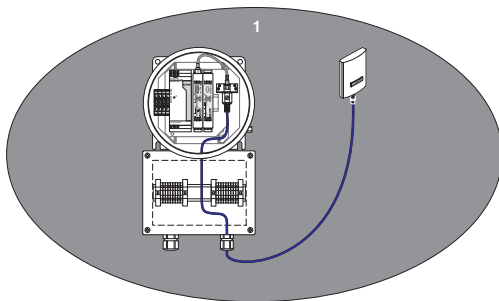

Figure 7 Installing the devices and antennas in zone 1

9.3 Installing the devices in zone 2 and the antennas in zone 1 or zone 0

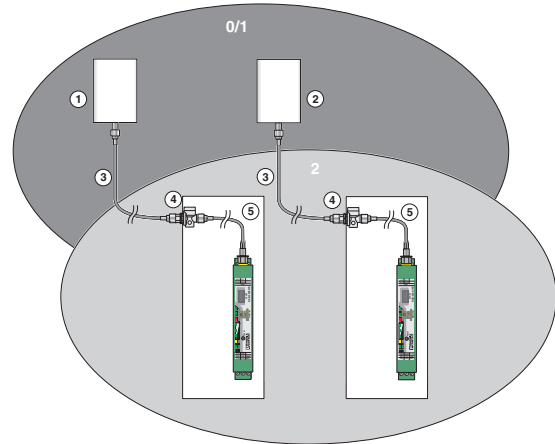

Figure 8 Installing the devices in zone 2 and the antennas in zone 1 or zone 0

Key:

- 1 Directional antenna
- 2 Directional antenna
- 3 Antenna cable
- 4 Antenna barrier
- 5 Adapter cable to the wireless module

9.4 Installing the devices in zone 1 and the antennas in zone 0

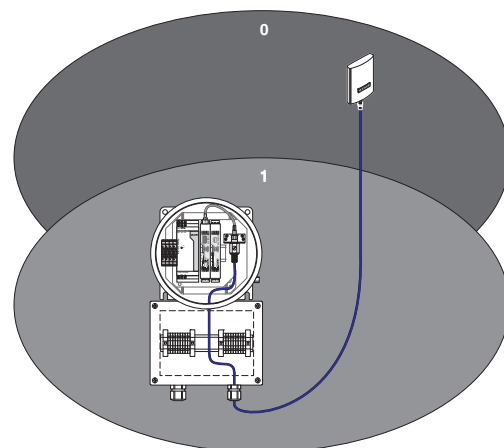

Figure 9 Installing the devices in zone 1 and the antennas in zone 0