



Chipsmall Limited consists of a professional team with an average of over 10 year of expertise in the distribution of electronic components. Based in Hongkong, we have already established firm and mutual-benefit business relationships with customers from,Europe,America and south Asia,supplying obsolete and hard-to-find components to meet their specific needs.

With the principle of “Quality Parts,Customers Priority,Honest Operation,and Considerate Service”,our business mainly focus on the distribution of electronic components. Line cards we deal with include Microchip,ALPS,ROHM,Xilinx,Pulse,ON,Everlight and Freescale. Main products comprise IC,Modules,Potentiometer,IC Socket,Relay,Connector.Our parts cover such applications as commercial,industrial, and automotives areas.

We are looking forward to setting up business relationship with you and hope to provide you with the best service and solution. Let us make a better world for our industry!



## Contact us

Tel: +86-755-8981 8866 Fax: +86-755-8427 6832

Email & Skype: info@chipsmall.com Web: www.chipsmall.com

Address: A1208, Overseas Decoration Building, #122 Zhenhua RD., Futian, Shenzhen, China



## Antenna - TC ANT MOBILE WALL 5M - 2702273

Please be informed that the data shown in this PDF Document is generated from our Online Catalog. Please find the complete data in the user's documentation. Our General Terms of Use for Downloads are valid (<http://phoenixcontact.com/download>)



Multiband mobile communication antenna with mounting bracket for outdoor installation, 5 m antenna cable with SMA circular connector, suitable for LTE/4G

### Why buy this product

- Optional wall or mast mounting

### Key Commercial Data

Packing unit	1 STK
GTIN	 4 055626 070186
GTIN	4055626070186

### Technical data

#### Dimensions

Caption	Wall mounting
Height	82 mm
Diameter	48 mm
Fixed cable length	5.00 m

#### Ambient conditions

Ambient temperature (operation)	-40 °C ... 80 °C
---------------------------------	------------------

#### General

With connecting cable	yes
Frequency range	700 MHz
	800 MHz
	850 MHz
	900 MHz
	1800 MHz
	1900 MHz

# Antenna - TC ANT MOBILE WALL 5M - 2702273

## Technical data

### General

	2100 MHz
	2600 MHz
Polarization	vertical
Impedance	50 $\Omega$
Gain	3 dBi (700 / 800 MHz)
	4 dBi (900/1800 MHz)
	5 dBi (1900 ... 2600 MHz)
Connection method	SMA (male)
Fixed cable length	5.00 m
Material	ABS (Antenna housing)
Mounting type	Mast mounting or wall mounting

### Environmental Product Compliance

China RoHS	Environmentally friendly use period: unlimited = EFUP-e
	No hazardous substances above threshold values

## Drawings

Schematic diagram

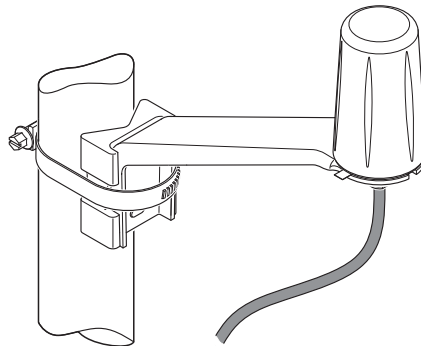

Mast mounting

## Antenna - TC ANT MOBILE WALL 5M - 2702273

Dimensional drawing

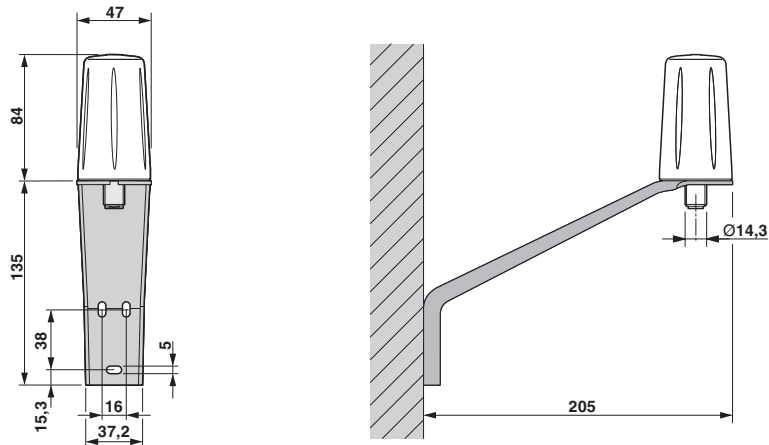

Wall mounting

Phoenix Contact 2018 © - all rights reserved  
<http://www.phoenixcontact.com>

PHOENIX CONTACT GmbH & Co. KG  
Flachsmarktstr. 8  
32825 Blomberg  
Germany  
Tel. +49 5235 300  
Fax +49 5235 3 41200  
<http://www.phoenixcontact.com>