



Chipsmall Limited consists of a professional team with an average of over 10 year of expertise in the distribution of electronic components. Based in Hongkong, we have already established firm and mutual-benefit business relationships with customers from,Europe,America and south Asia,supplying obsolete and hard-to-find components to meet their specific needs.

With the principle of “Quality Parts,Customers Priority,Honest Operation,and Considerate Service”,our business mainly focus on the distribution of electronic components. Line cards we deal with include Microchip,ALPS,ROHM,Xilinx,Pulse,ON,Everlight and Freescale. Main products comprise IC,Modules,Potentiometer,IC Socket,Relay,Connector.Our parts cover such applications as commercial,industrial, and automotives areas.

We are looking forward to setting up business relationship with you and hope to provide you with the best service and solution. Let us make a better world for our industry!



## Contact us

Tel: +86-755-8981 8866 Fax: +86-755-8427 6832

Email & Skype: info@chipsmall.com Web: www.chipsmall.com

Address: A1208, Overseas Decoration Building, #122 Zhenhua RD., Futian, Shenzhen, China



## Interface converters - GW MODBUS TCP/ASCII 1E/2DB9 - 2702769

Please be informed that the data shown in this PDF Document is generated from our Online Catalog. Please find the complete data in the user's documentation. Our General Terms of Use for Downloads are valid (<http://phoenixcontact.com/download>)



The GW MODBUS TCP/ASCII... converts RAW or ASCII serial strings into Modbus registers. Includes one RJ45 port and two D-SUB 9 ports.



### Key Commercial Data

Packing unit	1 STK
GTIN	 4 055626 339375
GTIN	4055626339375

### Technical data

#### Note

Utilization restriction	EMC: class A product, see manufacturer's declaration in the download area
-------------------------	---

#### Dimensions

Width	22.5 mm
Height	99 mm
Depth	115 mm

#### Ambient conditions

Ambient temperature (operation)	-40 °C ... 70 °C
Ambient temperature (storage/transport)	-40 °C ... 80 °C
Permissible humidity (operation)	10 % ... 95 % (non-condensing)
Permissible humidity (storage/transport)	5 % ... 95 % (non-condensing)
Altitude	< 2000 m
Degree of protection	IP20
Noise immunity	EN 61000-6-2:2005

#### General

Electrical isolation	IEC UL 61010-1 (VCC // Ethernet)
----------------------	----------------------------------

# Interface converters - GW MODBUS TCP/ASCII 1E/2DB9 - 2702769

## Technical data

### General

Test voltage data interface/data interface	1.5 kV <sub>rms</sub> (50 Hz, 1 min.)
Test voltage data interface/power supply	1.5 kV <sub>rms</sub>
	1.5 kV <sub>rms</sub> (50 Hz, 1 min.)
Standards/regulations	EN 55022, EN 55024
Electromagnetic compatibility	Conformance with EMC Directive 2014/30/EU
Noise emission	EN 61000-6-4
Net weight	125 g
Housing material	PA 6.6
Color	gray
MTBF	69.4 Years (Telcordia standard, 25°C temperature, 50% stress, Environmental Factor = 1.0)
	46.3 Years (Telcordia standard, 40°C temperature, 50% stress, environmental factor = 1.0)
Conformance	CE-compliant
UL, USA	UL 61010-1
UL, USA/Canada	Class I, Div. 2, Groups A, B, C, D T4A

### Power supply

Supply voltage range	10.8 V DC ... 30 V DC (via pluggable COMBICON screw terminal block)
Max. current consumption	85 mA (24 V DC)
Typical current consumption	76 mA (24 V DC)
Conductor cross section flexible max.	2.50 mm <sup>2</sup>
Conductor cross section flexible min.	0.20 mm <sup>2</sup>
Conductor cross section AWG max.	12
Conductor cross section AWG min.	24

### Serial interface

Interface 1	Modbus/TCP
Interface	Ethernet
No. of ports	1
Connection method	RJ45 socket, shielded
Transmission length	≤ 100 m (shielded twisted pair)
Auxiliary protocols	ARP, DHCP (Client), PING
Serial transmission speed	10/100 Mbps, auto negotiation
Interface	RS-232
Number of connections	2
Connection method	D-SUB 9 plug
File format/coding	5/6/7/8 Data bits, 1/2 Stop bits, None/Even/Odd/Mark/Space Parity
Transmission length	15 m
Data flow control/protocols	Software handshake, Xon/Xoff or hardware handshake RTS/CTS
Serial transmission speed	0.3; 0.6; 1.2; 2.4; 4.8; 9.6; 19.2; 38.4; 57.6; 115.2; 230.4 Kbps
Interface	RS-422



# Interface converters - GW MODBUS TCP/ASCII 1E/2DB9 - 2702769

## Technical data

### Serial interface

Number of connections	2
Connection method	D-SUB 9 plug
File format/coding	5/6/7/8 Data bits, 1/2 Stop bits, None/Even/Odd/Mark/Space Parity
Transmission length	≤ 1200 m
	120 Ω (configurable)
Serial transmission speed	0.3; 0.6; 1.2; 2.4; 4.8; 9.6; 19.2; 38.4; 57.6; 115.2; 230.4 Kbps
Interface	RS-485
Number of connections	2
Connection method	D-SUB 9 plug
File format/coding	5/6/7/8 Data bits, 1/2 Stop bits, None/Even/Odd/Mark/Space Parity
	120 Ω (configurable)
Serial transmission speed	0.3; 0.6; 1.2; 2.4; 4.8; 9.6; 19.2; 38.4; 57.6; 115.2; 230.4 Kbps

### Function

Web-based management	yes
Management	Web-based management

### Standards and Regulations

Electromagnetic compatibility	Conformance with EMC Directive 2014/30/EU
Type of test	Vibration resistance in acc. with EN 60068-2-6/IEC 60068-2-6
	Shock in acc. with EN 60068-2-27/IEC 60068-2-27
Noise emission	EN 61000-6-4
Noise immunity	EN 61000-6-2:2005
Standards/regulations	EN 55022, EN 55024
Conformance	CE-compliant
UL, USA	UL 61010-1
UL, USA/Canada	Class I, Div. 2, Groups A, B, C, D T4A
Noxious gas test	ISA-S71.04-1985 G3 Harsh Group A

### Environmental Product Compliance

REACH SVHC	Lead 7439-92-1
China RoHS	Environmentally Friendly Use Period = 50
	For details about hazardous substances go to tab "Downloads", Category "Manufacturer's declaration"

## Drawings

# Interface converters - GW MODBUS TCP/ASCII 1E/2DB9 - 2702769

Block diagram

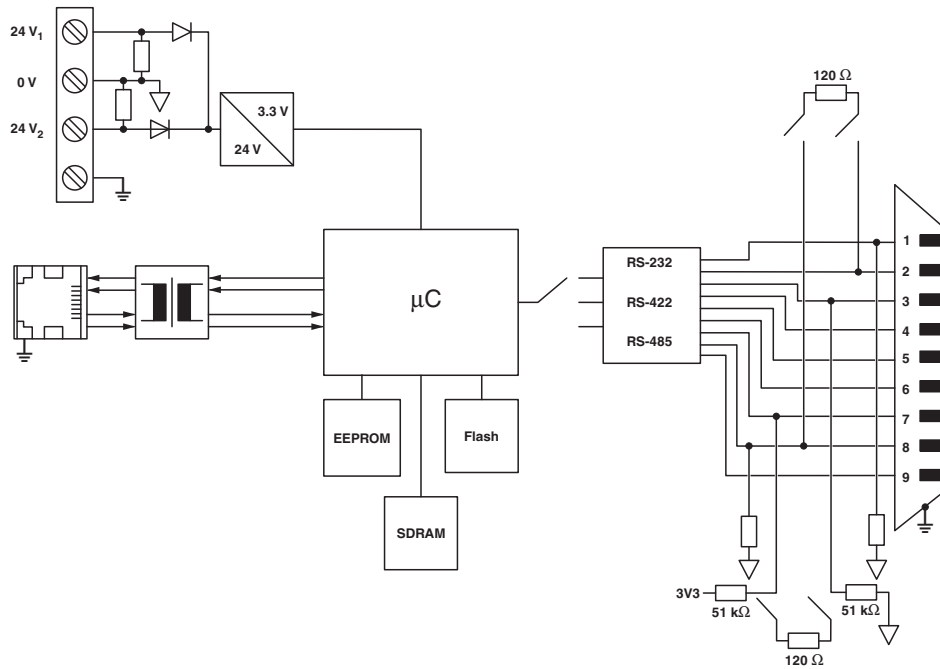

## Approvals

### Approvals

#### Approvals

UL Listed / cUL Listed / cULus Listed

#### Ex Approvals

UL Listed / cUL Listed / cULus Listed

### Approval details

UL Listed		<a href="http://database.ul.com/cgi-bin/XYV/template/LISEXT/1FRAME/index.htm">http://database.ul.com/cgi-bin/XYV/template/LISEXT/1FRAME/index.htm</a>	FILE E 238705
-----------	--	---	---------------

cUL Listed		<a href="http://database.ul.com/cgi-bin/XYV/template/LISEXT/1FRAME/index.htm">http://database.ul.com/cgi-bin/XYV/template/LISEXT/1FRAME/index.htm</a>	FILE E 238705
------------	--	---	---------------

cULus Listed			
--------------	--	--	--

---

Phoenix Contact 2018 © - all rights reserved  
<http://www.phoenixcontact.com>

PHOENIX CONTACT GmbH & Co. KG  
Flachsmarktstr. 8  
32825 Blomberg  
Germany  
Tel. +49 5235 300  
Fax +49 5235 3 41200  
<http://www.phoenixcontact.com>