



Chipsmall Limited consists of a professional team with an average of over 10 year of expertise in the distribution of electronic components. Based in Hongkong, we have already established firm and mutual-benefit business relationships with customers from,Europe,America and south Asia,supplying obsolete and hard-to-find components to meet their specific needs.

With the principle of "Quality Parts,Customers Priority,Honest Operation,and Considerate Service",our business mainly focus on the distribution of electronic components. Line cards we deal with include Microchip,ALPS,ROHM,Xilinx,Pulse,ON,Everlight and Freescale. Main products comprise IC,Modules,Potentiometer,IC Socket,Relay,Connector.Our parts cover such applications as commercial,industrial, and automotives areas.

We are looking forward to setting up business relationship with you and hope to provide you with the best service and solution. Let us make a better world for our industry!



## Contact us

Tel: +86-755-8981 8866 Fax: +86-755-8427 6832

Email & Skype: info@chipsmall.com Web: www.chipsmall.com

Address: A1208, Overseas Decoration Building, #122 Zhenhua RD., Futian, Shenzhen, China



# IL PN BK DI8 DO4 2TX-PAC

**PROFINET bus coupler, 8 inputs, 24 V DC, 4 outputs, 24 V DC, 500 mA, complete with I/O connectors**



Data sheet  
7410\_en\_12

© PHOENIX CONTACT 2017-07-24

## 1 Description

This description applies to firmware version 2.30 or later.

The bus coupler is the link between a PROFINET network and the Inline installation system. In addition, it is used to acquire and output digital signals.

Up to 61 Inline devices can be connected at any point to an existing PROFINET network using the bus coupler.

The bus coupler and the Inline devices form a station with a maximum of 63 local bus devices. Here, the inputs and outputs of the bus coupler together form the first local bus device.

### Features

- 2 x Ethernet twisted pair according to 802.3 with auto negotiation and auto crossover
- Transmission speed of 100 Mbps
- IP parameter setting using the PROFINET controller
- Connection to the PROFINET network via 8-pos. RJ45 socket
- Electrical isolation between Ethernet interface and logic
- Ethernet TCP/IP (100 Base-TX, Management via SNMP)
- Connection of up to 61 other Inline devices
- Connection of a maximum of 16 PCP devices
- Supported protocols: SNMPv1, TFTP, PROFINET, LLDP and MRP (from firmware 3.21)
- PROFINET IRT (Firmware 4.00 or later)
- Conformance with PROFINET specification V2.3 (Firmware 4.00 or later)
- PROFINET Netload Class III (Firmware 4.00 or later)
- 8 digital inputs, 4 digital outputs
- Automatic detection of the transmission speed in the local bus (500 kbps or 2 Mbps)
- Diagnostic and status indicators
- Hardware version 02 or later:  
Approved for use in zone 2 potentially explosive areas



**WARNING: Explosion hazard when used in potentially explosive areas**

When using the terminal in potentially explosive areas, observe the corresponding notes.



This data sheet is only valid in association with the IL SYS INST UM E user manual.



Make sure you always use the latest documentation.  
It can be downloaded from the product at [phoenixcontact.net/products](http://phoenixcontact.net/products).  
Here you will also find the current GSDML file.

---

<b>2</b>	<b>Table of contents</b>	
1	Description .....	1
2	Table of contents .....	2
3	Ordering data .....	3
4	Technical data .....	5
5	Internal circuit diagram .....	10
6	Local status and diagnostic indicators .....	11
7	Diagnostic indicators for PROFINET .....	12
8	Connection of PROFINET, power supply, actuators, and sensors.....	13
8.1	Connecting PROFINET .....	13
8.2	Terminal point assignment of the Inline connectors .....	14
9	Connection example.....	14
10	Instructions on using the bus coupler in the potentially explosive area .....	15
11	Mapping inputs and outputs to PROFINET .....	15
12	Process data.....	15
12.1	Terminal point assignment of local outputs to the OUT process data .....	15
12.2	Terminal point assignment of the local inputs to the IN process data.....	15
13	Startup.....	16
14	Parameterization .....	16
15	Firmware update.....	17
16	Physical Device - PDev.....	17
17	Link Layer Discovery Protocol - LLDP .....	17
18	Device replacement.....	17
19	Applicative system redundancy for process data.....	18
20	Failsafe behavior .....	18
21	Acyclic PROFINET communication .....	18
22	Mailbox communication.....	18
23	Byte rotation for 16 and 32-channel Inline terminals with a SIMATIC® S7 controller.....	19
23.1	Byte rotation for IB IL 24 DI 16... and IB IL 24 DO 16... terminals .....	19
23.2	Byte rotation for IB IL 24 DI 32... and IB IL 24 DO 32... terminals .....	20



### 3 Ordering data

Description	Type	Order No.	Pcs./Pkt.
PROFINET bus coupler, 8 inputs, 24 V DC, 4 outputs, 24 V DC, 500 mA, complete with I/O connectors	IL PN BK DI8 DO4 2TX-PAC	2703994	1
Accessories	Type	Order No.	Pcs./Pkt.
Quick mounting end clamp for NS 35/7,5 DIN rail or NS 35/15 DIN rail, with marking option, width: 9.5 mm, color: gray (Assembly)	CLIPFIX 35	3022218	50
Insert strip, Sheet, white, unlabeled, can be labeled with: Office printing systems: Laser printer, Mounting type: Insert, Lettering field: 62 x 46 mm (Marking)	ESL 62X46	0809502	5
Labeling field, width: 48.8 mm (Marking)	IB IL FIELD 8	2727515	10
Insert strip, Sheet, white, unlabeled, can be labeled with: Office printing systems: Laser printer, Mounting type: Insert, Lettering field: 62 x 10 mm (Marking)	ESL 62X10	0809492	1
Labeling field, width: 12.2 mm (Marking)	IB IL FIELD 2	2727501	10
RJ45 connector, shielded, with bend protection sleeve, 2 pieces, gray for straight cables, for assembly on site. For connections that are not crossed, it is recommended that you use the connector set with gray bend protection sleeve. (Connector/Adapter)	FL PLUG RJ45 GR/2	2744856	1
RJ45 connector, shielded, with bend protection sleeve, 2 pieces, green for crossed cables, for assembly on site. For connections that are crossed, it is recommended that the connector set with green bend protection sleeves is used. (Connector/Adapter)	FL PLUG RJ45 GN/2	2744571	1
CAT5-SF/UTP cable (J-02YS(ST)C HP 2 x 2 x 24 AWG), heavy-duty installation cable, 2 x 2 x 0.22 mm <sup>2</sup> , solid conductor, shielded, outer sheath: 7.8 mm diameter, inner sheath: 5.75 mm ± 0.15 mm diameter (Cable/conductor)	FL CAT5 HEAVY	2744814	1
CAT5-SF/UTP cable (J-LI02YS(ST)C H 2 x 2 x 26 AWG), light-duty, flexible installation cable 2 x 2 x 0.14 mm <sup>2</sup> , stranded, shielded, outer sheath: 5.75 mm ± 0.15 mm diameter (Cable/conductor)	FL CAT5 FLEX	2744830	1
Crimping pliers, for assembling the RJ45 plugs FL PLUG RJ45..., for assembly on site (Tools)	FL CRIMPTOOL	2744869	1
End clamp, Width: 9.5 mm, Height: 35.3 mm, Length: 50.5 mm, Color: gray (Assembly)	E/UK	1201442	50
Connector set, for Inline bus coupler with I/Os mounted in rows (Connector/Adapter)	IL BKDIO-PLSET	2878599	1

Documentation	Type	Order No.	Pcs./Pkt.
User manual, English, Automation terminals of the Inline product range	IL SYS INST UM E	-	-
Quick start guide, English, for PC Worx	UM QS EN PC WORX	-	-
Quick Start Guide, English, for planning INTERBUS devices in a PROFINET network	UM QS EN PROFINET PROXY IB	-	-
User manual, English, for the Modular Managed Switch System	FL SWITCH MM HS UM E	-	-
Application note, English, Inline terminals for use in zone 2 potentially explosive areas	AH EN IL EX ZONE 2	-	-
Application note, German/English, I/O modules at bus couplers	AH IL BK IO LIST	-	-
User manual, English, PROFINET basics	UM EN PROFINET SYS	-	-
User manual, English, Installation and operation of the PC Worx Firmware Updater software	UM EN PC WORX FIRMWARE UPDATER	-	-

## 4 Technical data

### Dimensions (nominal sizes in mm)

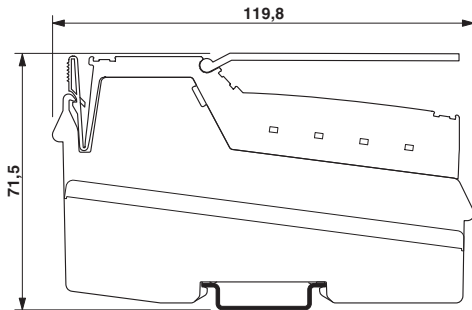

Width	80 mm
Height	119.8 mm
Depth	71.5 mm
Note on dimensions	Specifications with connectors

### General data

Color	green
Weight	340 g (with connectors)
Ambient temperature (operation)	-25 °C ... 55 °C (observe derating)
Ambient temperature (storage/transport)	-40 °C ... 85 °C
Permissible humidity (operation)	10 % ... 95 % (according to DIN EN 61131-2)
Permissible humidity (storage/transport)	10 % ... 95 % (according to DIN EN 61131-2)
Air pressure (operation)	70 kPa ... 106 kPa (up to 3000 m above sea level)
Air pressure (storage/transport)	70 kPa ... 106 kPa (up to 3000 m above sea level)
Degree of protection	IP20
Protection class	III, IEC 61140, EN 61140, VDE 0140-1

### Connection data

Designation	Inline connector
Connection method	Spring-cage connection
Conductor cross section solid / stranded	0.08 mm <sup>2</sup> ... 1.5 mm <sup>2</sup> / 0.08 mm <sup>2</sup> ... 1.5 mm <sup>2</sup>
Conductor cross section [AWG]	28
Stripping length	8 mm

### Connection data for UL approvals

Designation	Inline connector
Connection method	Spring-cage connection
Conductor cross section solid / stranded	0.2 mm <sup>2</sup> ... 1.5 mm <sup>2</sup> / 0.2 mm <sup>2</sup> ... 1.5 mm <sup>2</sup>
Conductor cross section [AWG]	24 ... 16
Stripping length	8 mm

**Interface PROFINET**

Number	2
Connection method	RJ45 socket, auto negotiation
Transmission speed	100 Mbps (acc. to PROFINET standard)
Transmission physics	Ethernet in RJ45 twisted pair
Transmission length	max. 100 m

**Interface Inline local bus**

Connection method	Inline data jumper
Transmission speed	500 kbps / 2 Mbps (Automatic detection, no combined system)

**System limits**

Amount of process data	max. 488 Byte (Max. 244 bytes IN - max. 244 bytes OUT)
IN process data for I/O modules that can be aligned	244 Byte
OUT process data for I/O modules that can be aligned	244 Byte
Number of supported devices	max. 63 (per station)
Number of local bus devices that can be connected	max. 61 (on board I/Os are two devices)
Number of devices with parameter channel	max. 16
Number of supported branch terminals with remote bus branch	0



Observe the logic current consumption of each device when configuring an Inline station! It is specified in every terminal-specific data sheet. The current consumption can differ depending on the individual terminal. The permissible number of devices that can be connected therefore depends on the specific station structure.

**PROFINET**

Device function	PROFINET device
Update rate	min. 1 ms (depending on the size of the bus system)

**Protocols supported**

Protocols supported	PROFINET, PDev, TFTP, ICMP, LLDP
---------------------	----------------------------------

**Power supply for module electronics**

Connection method	Spring-cage connection
Designation	Bus coupler supply $U_{BC}$ ; Communications power $U_L$ (7.5 V) and the analog supply $U_{ANA}$ (24 V) are generated from the bus coupler supply.
Supply voltage	24 V DC (via Inline connector)
Supply voltage range	19.2 V DC ... 30 V DC (including all tolerances, including ripple)
Supply current	138 mA
Current consumption	typ. 138 mA (from $U_{BK}$ ) max. 0.91 A DC (from $U_{BK}$ )
Power dissipation	typ. 3 W (entire device)

**Power consumption****NOTE: Electronics may be damaged when overloaded**

Provide external fuses for the 24 V areas  $U_{BK}$ ,  $U_M$ , and  $U_S$ . The power supply unit must be able to supply four times the nominal current of the external fuse, to ensure that it trips in the event of an error.

Main circuit supply $U_M$	24 V DC -15 % / +20 % (acc. to EN 61131-2)
Supply voltage range $U_M$	19.2 V DC ... 30 V DC (including all tolerances, including ripple)
Power supply at $U_M$	max. 8 A DC (Sum of $U_M + U_S$ ; 4 A, maximum, when used in potentially explosive areas.)
Current consumption from $U_M$	max. 8 A DC
Segment circuit supply $U_S$	24 V DC -20 % / +20 % (acc. to EN 61131-2)
Supply voltage range $U_S$	19.2 V DC ... 30 V DC (including all tolerances, including ripple)
Power supply at $U_S$	max. 8 A DC (Sum of $U_M + U_S$ ; 4 A, maximum, when used in potentially explosive areas.)
Current consumption from $U_S$	max. 8 A DC
Communications power $U_L$	7.5 V DC $\pm$ 5 %
Power supply at $U_L$	max. 0.8 A DC (observe derating)
I/O supply voltage $U_{ANA}$	24 V DC -15 % / +20 %
Supply voltage range $U_{ANA}$	19.2 V DC ... 30 V DC (including all tolerances, including ripple)
Power supply at $U_{ANA}$	max. 0.5 A DC (observe derating)

**Power dissipation**

Maximum power dissipation for nominal condition	max. 3.3 W
---	------------

**Digital inputs**

Number of inputs	8
Connection method	Inline connector
Connection technology	2, 3-wire
Description of the input	EN 61131-2 type 1
Input characteristic curve	IEC 61131-2 type 1
Nominal input voltage	24 V DC
Nominal input current	typ. 3 mA
Current flow	Limited to 3 mA, maximum
Input voltage range "0" signal	-30 V DC ... 5 V DC
Input voltage range "1" signal	15 V DC ... 30 V DC
Delay at signal change from 0 to 1	typ. 5 ms
Delay at signal change from 1 to 0	typ. 5 ms
Permissible conductor length to the sensor	100 m
Reverse polarity protection	Polarity protection diode

**Digital outputs**

Number of outputs	4
Connection method	Inline connector
Connection technology	2, 3-wire
Nominal output voltage	24 V DC
Voltage difference with nominal current	< 1 V



<b>Digital outputs</b>	
Maximum output current per channel	500 mA
Maximum output current per device	2 A
Nominal load, ohmic	12 W
Nominal load, inductive	12 VA (1.2 H, 48 Ω)
Nominal load, lamp	12 W
Signal delay	typ. 1.2 ms
Signal delay when switching on an ohmic nominal load	max. 50 μs (in the case of 0.5 A load)
Signal delay when switching off an ohmic nominal load	max. 250 μs (in the case of 0.5 A load)
Maximum operating frequency with inductive nominal load	0.5 Hz (1.2 H, 48 Ω)
Reaction time with short-circuit	1,2 ms
Behavior at voltage switch-off	The output follows the power supply without delay
Limitation of the voltage induced on circuit interruption	approx. -30 V
Output current when switched off	max. 10 μA (When not loaded, a voltage can be measured even at an output that is not set.)
Behavior with overload	Auto restart
Behavior with inductive overload	Output can be destroyed
Reverse voltage resistance to short pulses	Reverse voltage proof
Resistance to permanent reverse voltage	max. 2 A
Overcurrent shut-down	min. 0.7 A
Short-circuit and overload protection	Free running circuit In output driver

<b>Error messages to the higher level control or computer system</b>	
Short-circuit / overload of the digital outputs	Yes
Sensor supply failure	Yes
Failure of the actuator supply	Yes

<b>Protective circuit</b>	
Surge protection, protection against polarity reversal of the supply voltage	35 V suppressor diode

<b>Mechanical tests</b>	
Vibration resistance in acc. with EN 60068-2-6/ IEC 60068-2-6	5g
Shock in acc. with EN 60068-2-27/IEC 60068-2-27	Operation: 25g, 11 ms duration, semi-sinusoidal shock impulse

<b>Conformance with EMC Directive 2014/30/EU</b>	
<b>Noise immunity test in accordance with EN 61000-6-2</b>	
Electrostatic discharge (ESD) EN 61000-4-2/ IEC 61000-4-2	Criterion B, 6 kV contact discharge, 8 kV air discharge
Electromagnetic fields EN 61000-4-3/IEC 61000-4-3	Criterion A, Field intensity: 10 V/m
Fast transients (burst) EN 61000-4-4/IEC 61000-4-4	Criterion A, all interfaces 1 kV Criterion B, all interfaces 2 kV
Transient overvoltage (surge) EN 61000-4-5/ IEC 61000-4-5	Criterion B, supply lines DC: 0.5 kV/0.5 kV (symmetrical/ asymmetrical), fieldbus cable shield 1 kV

**Conformance with EMC Directive 2014/30/EU**

Conducted interference EN 61000-4-6/IEC 61000-4-6 Criterion A; Test voltage 10 V

**Noise emission test as per EN 61000-6-4**

EN 55011 Class A

**Approvals**

For the latest approvals, please visit [phoenixcontact.net/products](http://phoenixcontact.net/products).

**Mounting position and derating**

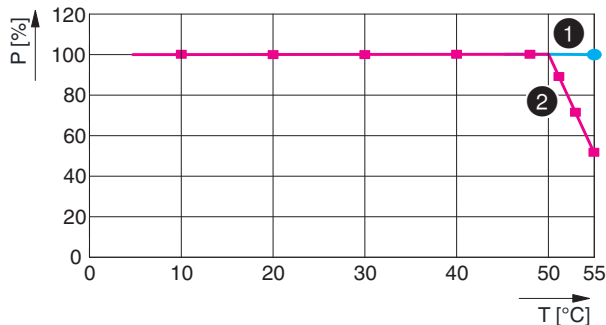

**The following results from the information given above:**

- When used at 55°C (on horizontal DIN rail)  
When mounted on a horizontal DIN rail, you can operate the bus coupler at 55°C and 24 V without any limitation.
- When used at 55°C (different mounting position)  
With a different mounting position, you can operate the bus coupler at 55°C and 24 V with a maximum load of 50%.

Figure 1 Derating with different mounting positions

Key:

- 1 Mounting on a horizontal DIN rail
- 2 Different mounting position
- P [%] Power dissipation in percent
- T [°C] Ambient temperature in °C

The specifications refer to a supply voltage of 24 V.

When you are working with a voltage from the upper voltage range (e.g., 30 V), the percentage values increase. In this case, multiply the percentage values with 1.25 (30 V/24 V = 1.25).

The various bus coupler functions have different percentage shares of the power dissipation.

Please refer to the percentage shares in the following table.

Function	Percentage shares of power dissipation in %
Inputs	25
Outputs	16
U <sub>M</sub>	24
U <sub>ANA</sub>	3
U <sub>L</sub>	32

5 Internal circuit diagram

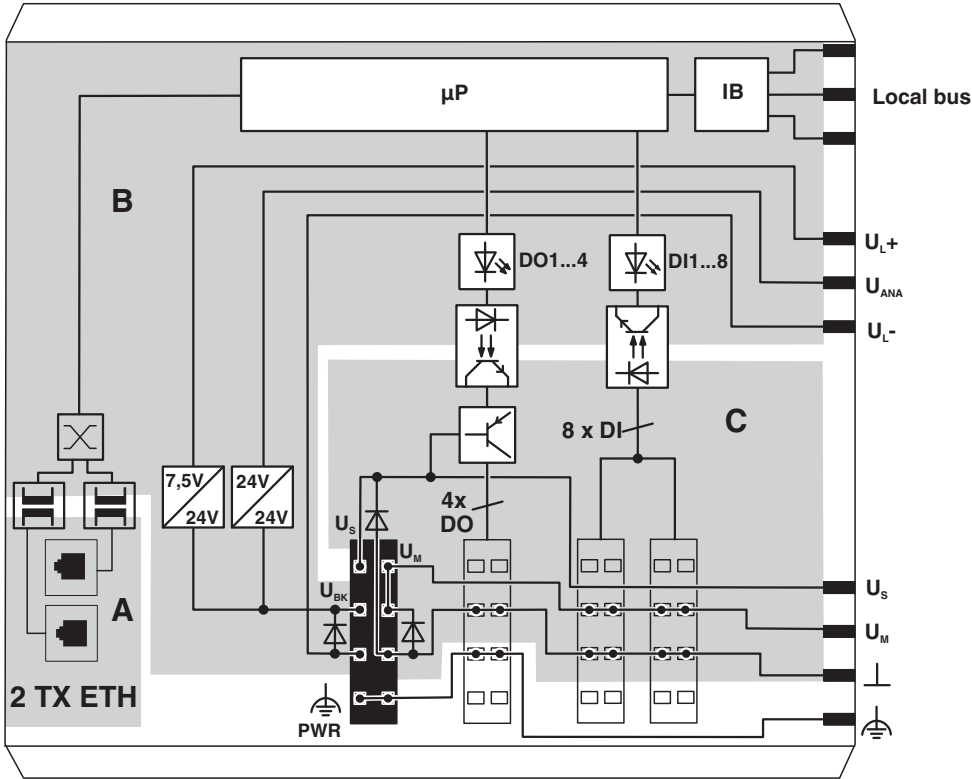



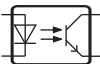





Figure 2 Internal wiring of connections

Key:

-  Microprocessor
-  Protocol chip
-  LED
-  Optocoupler
-  PNP transistor
-  Ethernet switch
-  Transmitter with electrical isolation

The gray areas in the basic circuit diagram represent the electrically isolated areas:

- A: Ethernet interface
- B: Logic
- C: I/O

 Explanation for other used symbols has been provided in the IL SYS INST UM E user manual.

## 6 Local status and diagnostic indicators

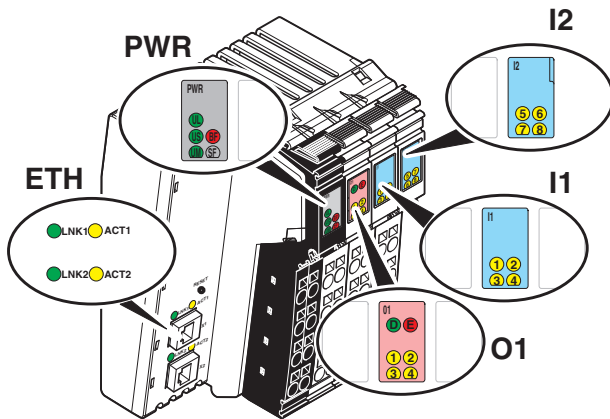

Figure 3 Local diagnostic and status indicators

Designation	Color	Meaning	State	Description
LNK 1/2	green	Link port 1/2	ON	Connection via Ethernet to a module via port 1/2 established
			flashing	PROFINET module identification ("flashing")
			OFF	No connection established via port 1/2
ACT 1/2	yellow	Activity port 1/2	ON	Transmission or reception of Ethernet telegrams at port 1/2
			OFF	No transmission or reception of Ethernet telegrams at port 1/2
BF	red	Communication error ( <b>B</b> us <b>F</b> ault)	ON	No link status available
			flashing	Link status available, no communication connection to the PROFINET controller
			OFF	A PROFINET controller has established an active communication connection to the PROFINET device.
SF	red	System failure (PROFINET)	ON	PROFINET diagnostics available
			OFF	PROFINET diagnostics not available
UL	green	<b>U</b> <sub>Logic</sub>	ON	24 V bus coupler supply/7.5 V communications power present
			OFF	24 V bus coupler supply/7.5 V communications power not present
US	green	<b>U</b> <sub>segment</sub>	ON	24 V segment circuit supply present
			OFF	24 V segment circuit supply not present
UM	green	<b>U</b> <sub>Main</sub>	ON	24 V main circuit supply/internal communications power present
			OFF	24 V main circuit supply/internal communications power present
D	green	<b>D</b> iagnostics	ON	Data transmission active within the station
			flashing	Data transmission not active within the station
E	red	Error	ON	I/O error, short-circuit/overload of outputs
			OFF	No I/O error
1 ... 4	yellow	O1	ON/OFF	Output is set/not set.
1 ... 8	yellow	I1, I2	ON/OFF	Input is set/not set.

## 7 Diagnostic indicators for PROFINET

### States during operation

LED	Meaning
SF OFF/BF flashing	PROFINET device is waiting for communication with the PROFINET controller.
SF OFF/BF OFF	PROFINET controller was able to establish communication without errors.

### States in the event of an error

LED	Meaning	Measure/remedy in the event of an error
SF OFF/BF flashing	The logic communication connection has been interrupted. The PROFINET controller can no longer be accessed.	Check the connection between the PROFINET controller and the PROFINET device. Make sure that the PROFINET device name of the PROFINET device is identical with the configuration.
SF OFF/BF flashing	The PROFINET device is not assigned a PROFINET device name.	Assign the PROFINET device name using the relevant tool.
SF OFF/BF ON	The physical communication path has been interrupted. The PROFINET controller can no longer be accessed.	Restore the physical connection between the PROFINET controller and the PROFINET device.
SF ON/BF OFF	Diagnostic data is available.	Read the diagnostic message using the relevant tool.
SF flashing/ BF flashing	Hardware watchdog has been triggered.	



## 8 Connection of PROFINET, power supply, actuators, and sensors

### 8.1 Connecting PROFINET

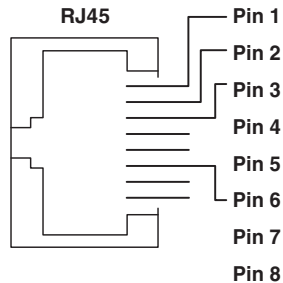

Figure 4 Pin assignment of the Ethernet socket (RJ45)

Connect PROFINET to the bus coupler via an 8-pos. RJ45 connector.

Only one twisted pair cable with an impedance of 100 Ω may be connected to each Ethernet interface in RJ45 format. The data transmission speed is 100 Mbps. The 100Base-TX port of the bus coupler is able to detect a pair of incorrectly connected receive cables (RD+/RD-) and to correct them using the auto polarity correction function.

For the pin assignment, refer to the following table:

Pin	Assignment
1	TxD + (transmit data +)
2	TxD - (transmit data -)
3	RxD+ (receive data +)
4	Reserved
5	Reserved
6	RxD- (receive data -)
7	Reserved
8	Reserved



**Auto crossover**  
Both Ethernet interfaces are provided with the auto crossover function.



**Shielding**  
The shielding ground of the connected twisted pair cables is electrically connected with the socket. When connecting network segments, avoid ground loops, potential transfers, and voltage equalization currents via the braided shield.



**Observe bending radii**  
The housing dimensions specified under "Dimensions" refer to the bus coupler with I/O connectors without Ethernet connection. When installing the bus coupler in a control box, observe the bending radii of the Ethernet cables and the connectors used (e.g., FL CAT5 FLEX: 30 mm for fixed installation and FL CAT5 HEAVY: 30 mm without outer sheath and 45 mm with outer sheath). If required, use angled RJ45 connectors to maintain these bending radii.

8.2 Terminal point assignment of the Inline connectors

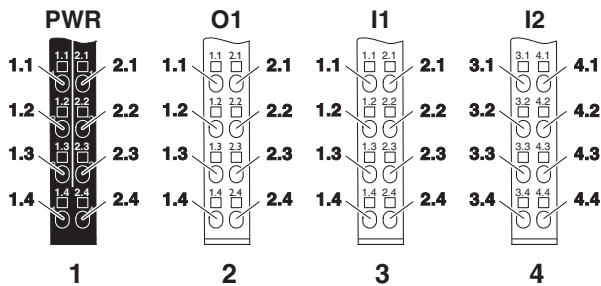

Figure 5 Terminal point assignment

Terminal point assignment of the power plug PWR (1)

Terminal point	Assignment	Terminal point	Assignment
1.1	U <sub>S</sub>	2.1	U <sub>M</sub>
1.2	U <sub>BK</sub>	2.2	U <sub>M</sub>
1.3	GND U <sub>BK</sub>	2.3	GND U <sub>M</sub> , U <sub>S</sub>
1.4	Functional earth ground (FE)	2.4	Functional earth ground (FE)



**NOTE: Malfunction**

The module is designed exclusively for SELV operation according to IEC 950/EN 60950/ VDE 0805.



For information on the power supplies, please refer to the IL SYS INST UM E user manual.



If you want to use the same reference potential for communications power and segment voltage, you can bridge the terminal points 1.3 and 2.3 on the connector.

Terminal point assignment of the output plug O1 (2)

Terminal point	Assignment	Terminal point	Assignment
1.1	OUT1	2.1	OUT2
1.2	GND	2.2	GND
1.3	FE	2.3	FE
1.4	OUT3	2.4	OUT4

Terminal point assignment of the input plug I1 (3)

Terminal point	Assignment	Terminal point	Assignment
1.1	IN1	2.1	IN2
1.2	U <sub>M</sub>	2.2	U <sub>M</sub>
1.3	GND	2.3	GND
1.4	IN3	2.4	IN4

Terminal point assignment of the input plug I2 (4)

Terminal point	Assignment	Terminal point	Assignment
3.1	IN5	4.1	IN6
3.2	U <sub>M</sub>	4.2	U <sub>M</sub>
3.3	GND	4.3	GND
3.4	IN7	4.4	IN8

9 Connection example

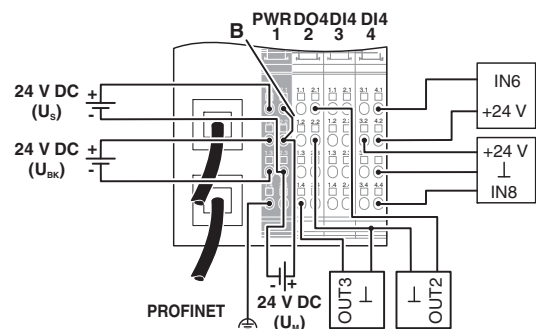

Figure 6 Connection example

## 10 Instructions on using the bus coupler in the potentially explosive area



**WARNING: Explosion hazard**

Please make sure that the following notes and instructions are observed.

### Approval according to ATEX Directive 2014/34/EU

Ⓜ II 3 G Ex nA IIC T4 Gc X

T<sub>amb</sub> = -25 °C ... +55 °C (horizontal mounting position)

T<sub>amb</sub> = -25 °C ... +55 °C (use at 55 °C and other mounting position: max. 50 % utilization)

### Installation notes

The category 3 device is designed for installation in zone 2 potentially explosive areas.

The device meets the requirements of EN 60079–0:2012 + A11:2013 and EN 60079–15:2010.

- Observe the specified conditions for use in potentially explosive areas! Also observe the requirements of EN 60079-14.
- Install the device in a suitable approved housing (with at least IP54 protection) that meets the requirements of EN 60079-15.
- Connect the DIN rail to the protective earth ground.
- Only devices that are designed for operation in Ex Zone 2 and the conditions at the installation location may be connected to the circuits in Zone 2.
- Only assemble, disassemble as well as connect and disconnect cables when the power is disconnected.
- For safe operation, lockable plug connections must have a functional interlock (e. g. locking clip, screw connection etc.). Insert the interlock. Repair any damaged connectors immediately.
- Only connect one cable per terminal point.
- Make sure that the supplies of U<sub>M</sub> and U<sub>S</sub> at the bus coupler do not exceed 4 A.
- When using the device in potentially explosive areas, observe the specifications in the application note AH DE IL EX ZONE 2 (German) / AH EN IL EX ZONE 2 (English).

## 11 Mapping inputs and outputs to PROFINET

The module uses the following input and output data words:

Slot	Data length
Slot 0	-
Slot 1	4 words IN/4 words OUT (local bus master)
Slot 2	1 byte OUT (DO4)
Slot 3	1 byte IN (DI8)

## 12 Process data

### 12.1 Terminal point assignment of local outputs to the OUT process data

Byte	0							
Bit	7	6	5	4	3	2	1	0
Slot	Not used				2 (O1)			
Terminal point (signal)					2.4	1.4	2.1	1.1
Terminal point (GND)					2.2	1.2	2.2	1.2
Terminal point (FE)					2.3	1.3	2.3	1.3
Status indicator, LED					4	3	2	1

### 12.2 Terminal point assignment of the local inputs to the IN process data

Byte	0							
Bit	7	6	5	4	3	2	1	0
Slot	4 (I2)				3 (I1)			
Terminal point (signal)	4.4	3.4	4.1	3.1	2.4	1.4	2.1	1.1
Terminal point (GND)	4.3	3.3	4.3	3.3	2.3	1.3	2.3	1.3
Terminal point (24 V)	4.2	3.2	4.2	3.2	2.2	1.2	2.2	1.2
Status indicator, LED	8	7	6	5	4	3	2	1

## 13 Startup



Make sure you always use the latest version of the FDCML/GSDML file and the latest documentation for the bus coupler. The latest files and documentation can be found on the Internet at [phoenixcontact.net/products](http://phoenixcontact.net/products).

### Default upon delivery/default settings

By default upon delivery, the following functions and features are available:

PROFINET name: No name assigned  
 IP parameters: none  
 Module designation: IL PN BK DI8 DO4 2TX

Vendor ID: 00B0<sub>hex</sub>  
 Device ID: 000A<sub>hex</sub>

### Reset button

The reset button is on the front of the bus coupler.

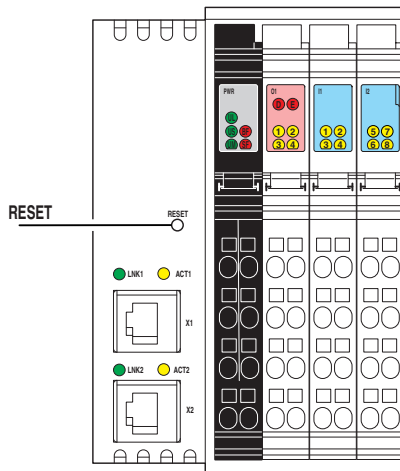

Figure 7 Reset button

The bus coupler is restarted by pressing the reset button. The outputs of the Inline station are reset. The process image of the inputs is not re-read.

### Firmware started

Once you have supplied the bus coupler with power or pressed the reset button, the firmware is started. After completion of the firmware boot process the BF LED is either on or flashing.

## Documentation



How to assign the PROFINET names and the IP address as well as how to startup a device within a PROFINET system is described in the following documents:

- "PC WORX" quick start guide
- "Configuring INTERBUS devices in a PROFINET network using the example of STEP 7" quick start guide

For the order designations, please refer to the ordering data.

The documentation can be found on the Internet at [phoenixcontact.net/products](http://phoenixcontact.net/products).

## 14 Parameterization

### PC Worx

Parameterization of the PROFINET devices in PC Worx requires at least PC Worx version 5.0. An online data sheet of the device with important technical data and a configuration file are integrated into PC Worx. If several versions of the configuration file are available, make sure that you are working with the file version that corresponds to the firmware/hardware version being used.

### Other tools

The PROFINET device is parameterized using the configuration tool of the PROFINET controller. Please integrate the corresponding GSDML file of the bus coupler into the relevant software tool (STEP 7/HW Config, ...).



Make sure you always use the latest version of the FDCML/GSDML file and the latest documentation for the bus coupler. The latest files and documentation can be found on the Internet at [phoenixcontact.net/products](http://phoenixcontact.net/products).

### Parameter

Slot 0: Diagnostic alarms

- PROFINET alarm behavior
  - Local bus diagnostics
  - I/O diagnostics
  - Indicate return of local module
- Local bus settings
  - Automatic start after local bus error
  - Automatic start delay

Slot 1: -

**PC Worx:** All registers are mapped to system variables.

**Step 7:** There are four words of input data and four words of output data.

Word	Input data	Output data
1	Diagnostic status register	Standard function start register
2	Diagnostic parameter register	Standard function parameter register
3	Extended diagnostic parameter register	Reserved
4	Standard function status register	Reserved

### Diagnostic alarms

PROFINET enables the PROFINET device to store diagnostic information together with the error location and error type.

An incoming alarm informs the PROFINET controller that diagnostic information has been stored. The alarms are only transmitted if they have been enabled via parameters during startup.

When the diagnostic information has been removed, an outgoing alarm is transmitted to the controller.

If at least one piece of diagnostic information is stored, the SF LED is on. If no diagnostic information is present, the SF LED is off.

### Substitute value behavior

In the event of an local bus error or a device error of the bus coupler, all Inline station outputs (including analog outputs) are set to "0".

## 15 Firmware update

The bus coupler firmware is updated using the "PC Worx Firmware Updater" software.



For more detailed information regarding the firmware update, refer to the "Installation and operation of the PC Worx Firmware Updater software" user manual.

## 16 Physical Device - PDev

The module supports all devices of the PDev according to PROFINET.

PDev is a standardized description in PROFINET of the Ethernet interfaces and their features. This includes, for example, the IP and MAC address, diagnostic and neighborhood information, and parameterization settings.

## 17 Link Layer Discovery Protocol - LLDP

The device supports LLDP according to IEEE 802.1 AB and thus enables topology detection of devices that also have LLDP activated.

Advantages of using LLDP:

- Improved error location detection
- Improved device replacement
- More efficient network configuration

The following information is received by or sent to neighbors, as long as LLDP is activated:

- The device sends its own management and connection information to neighboring devices.
- The device receives management and connection information from neighboring devices.

### Displaying LLDP information

Engineering tools can be used to represent the LLDP information as a topology overview.



For additional information on LLDP, please refer to the FL SWITCH MM HS UM E user manual.

## 18 Device replacement

Devices can be replaced without having to reconfigure them within the PROFINET network. The station name and address are assigned by the control system to the newly added PROFINET bus coupler using the neighborhood detection function.



Device replacement is possible for Phoenix Contact PROFINET controllers from firmware version 3.0 onwards.



## 19 Applicative system redundancy for process data



Applicative system redundancy is only provided for process data but not for parameter data.

Acyclic communication allows two PROFINET controllers (primary and backup) to communicate with the same bus coupler.

Parallel PCP services are not supported. This means, if a second PROFINET controller tries to access a PCP device while there is another PROFINET controller with a service pending, the second service request is rejected by the bus coupler.

With regard to communication, no distinction is made between the "primary" (process controlling) and the "backup" controller.

## 20 Failsafe behavior

In the event of a network failure, previously determined I/O values are output.

If PROFINET communication fails, all output process data is set to zero. The local bus continues to run using these values.



Substitute values are not parameterized.

## 21 Acyclic PROFINET communication

The bus coupler enables acyclic access to intelligent local bus devices (PCP devices) using PROFINET (Record Read function block, Record Write function block).

## 22 Mailbox communication

The bus coupler supports acyclic mailbox communication. This means specific PLC blocks allow acyclic transmission of firmware services (e.g., Read-Value, PCP) from the control system to the PROFINET device or PCP device with the Record Read and Record Write PROFINET services.



Additional PCP information can be found in the IBS SYS PCP G4 UM E user manual.

## 23 Byte rotation for 16 and 32-channel Inline terminals with a SIMATIC® S7 controller

To adapt the data format of the 16 and 32-channel Inline terminals to the data format of a SIMATIC® S7 controller, you can rotate the I/O data arrangement with device parameters. This adaptation can only be made once and is then valid for all DI16/DO16 and all DI32/DO32 terminals.

### 23.1 Byte rotation for IB IL 24 DI 16... and IB IL 24 DO 16... terminals

#### Default

(Word.bit) view	Word	Word 0															
	Bit	15	14	13	12	11	10	9	8	7	6	5	4	3	2	1	0
(Byte.Bit) view	Byte	Byte 0								Byte 1							
	Bit	7	6	5	4	3	2	1	0	7	6	5	4	3	2	1	0
Slot		4				3				2				1			
Terminal point		8.4	7.4	8.1	7.1	6.4	5.4	6.1	5.1	4.4	3.4	4.1	3.1	2.4	1.4	2.1	1.1

#### Rotated

(Word.bit) view	Word	Word 0															
	Bit	15	14	13	12	11	10	9	8	7	6	5	4	3	2	1	0
(Byte.Bit) view	Byte	Byte 0								Byte 1							
	Bit	7	6	5	4	3	2	1	0	7	6	5	4	3	2	1	0
Slot		2				1				4				3			
Terminal point		4.4	3.4	4.1	3.1	2.4	1.4	2.1	1.1	8.4	7.4	8.1	7.1	6.4	5.4	6.1	5.1

23.2 Byte rotation for IB IL 24 DI 32... and IB IL 24 DO 32... terminals

Default

(Word.bit) view	Word	Word 0															
	Bit	15	14	13	12	11	10	9	8	7	6	5	4	3	2	1	0
(Byte.Bit) view	Byte	Byte 0								Byte 1							
	Bit	7	6	5	4	3	2	1	0	7	6	5	4	3	2	1	0
Slot		4								3							
Terminal point		8.4	7.4	8.3	7.3	8.2	7.2	8.1	7.1	6.4	5.4	6.3	5.3	6.2	5.2	6.1	5.1

(Word.bit) view	Word	Word 1															
	Bit	15	14	13	12	11	10	9	8	7	6	5	4	3	2	1	0
(Byte.Bit) view	Byte	Byte 2								Byte 3							
	Bit	7	6	5	4	3	2	1	0	7	6	5	4	3	2	1	0
Slot		2								1							
Terminal point		4.4	3.4	4.3	3.3	4.2	3.2	4.1	3.1	2.4	1.4	2.3	1.3	2.2	1.2	2.1	1.1

Rotated

(Word.bit) view	Word	Word 0															
	Bit	15	14	13	12	11	10	9	8	7	6	5	4	3	2	1	0
(Byte.Bit) view	Byte	Byte 0								Byte 1							
	Bit	7	6	5	4	3	2	1	0	7	6	5	4	3	2	1	0
Slot		1								2							
Terminal point		2.4	1.4	2.3	1.3	2.2	1.2	2.1	1.1	4.4	3.4	4.3	3.3	4.2	3.2	4.1	3.1

(Word.bit) view	Word	Word 1															
	Bit	15	14	13	12	11	10	9	8	7	6	5	4	3	2	1	0
(Byte.Bit) view	Byte	Byte 2								Byte 3							
	Bit	7	6	5	4	3	2	1	0	7	6	5	4	3	2	1	0
Slot		3								4							
Terminal point		6.4	5.4	6.3	5.3	6.2	5.2	6.1	5.1	8.4	7.4	8.3	7.3	8.2	7.2	8.1	7.1