



Chipsmall Limited consists of a professional team with an average of over 10 year of expertise in the distribution of electronic components. Based in Hongkong, we have already established firm and mutual-benefit business relationships with customers from,Europe,America and south Asia,supplying obsolete and hard-to-find components to meet their specific needs.

With the principle of “Quality Parts,Customers Priority,Honest Operation,and Considerate Service”,our business mainly focus on the distribution of electronic components. Line cards we deal with include Microchip,ALPS,ROHM,Xilinx,Pulse,ON,Everlight and Freescale. Main products comprise IC,Modules,Potentiometer,IC Socket,Relay,Connector.Our parts cover such applications as commercial,industrial, and automotives areas.

We are looking forward to setting up business relationship with you and hope to provide you with the best service and solution. Let us make a better world for our industry!



Contact us

Tel: +86-755-8981 8866 Fax: +86-755-8427 6832

Email & Skype: info@chipsmall.com Web: www.chipsmall.com

Address: A1208, Overseas Decoration Building, #122 Zhenhua RD., Futian, Shenzhen, China



Electronic housing - UM122-PROFIL 235CM - 2735438

Please be informed that the data shown in this PDF Document is generated from our Online Catalog. Please find the complete data in the user's documentation. Our General Terms of Use for Downloads are valid (<http://download.phoenixcontact.com>)

Profile PC board base, with a constructional width of 122 mm and a fixed length of 235 cm



Key commercial data

Packing unit	1 PCE
GTIN	 4 017918 589561
Custom tariff number	39162000
Country of origin	GERMANY

Technical data

General

Housing type	Panel mounting base
Housing material	PVC
Color	green

Ambient conditions

Ambient temperature (operation)	-15 °C ... 50 °C
---------------------------------	------------------

Dimensions

Length	235 cm
Width	122 mm

Technical data

Inflammability class according to UL 94	V0
---	----

Electronic housing - UM122-PROFIL 235CM - 2735438

Classifications

eCl@ss

eCl@ss 4.0	27180401
eCl@ss 4.1	27180401
eCl@ss 5.0	27180506
eCl@ss 5.1	27180506
eCl@ss 6.0	27180802
eCl@ss 7.0	27182701
eCl@ss 8.0	27182701

ETIM

ETIM 2.0	EC001031
ETIM 3.0	EC001031
ETIM 4.0	EC001031
ETIM 5.0	EC000721

UNSPSC

UNSPSC 6.01	31261501
UNSPSC 7.0901	31261501
UNSPSC 11	31261501
UNSPSC 12.01	31261501
UNSPSC 13.2	31261501

Accessories

Accessories

Assembly

Electronic housing - UM122-FE - 2909471

UM 122 FE foot element, for UM 122 profile housing



Electronic housing - UM122-A/U92 - 2909455

UM 122-A/U 92 U-shaped cover, 92 mm wide for UM 122

Electronic housing - UM122-PROFIL 235CM - 2735438

Accessories

Electronic housing - UM122-FE - 2909471

UM 122 FE foot element, for UM 122 profile housing



Marking

Module marker carrier - PMB - 1004364



Phoenix module marker carrier, for labeling modules and PCBs, for hole diameter 3.9 to 4.1 mm, thickness of wall or board 1.5 - 2.0 mm, labeling with insert strips ESL, EST or ES/LP-BW-GB, lettering field: 29 x 8 mm

Marker pen - B-STIFT - 1051993



Marker pen, for manual labeling of unprinted Zack strips, smear-proof and waterproof, line thickness 0.5 mm

Insert strip - AP-ES - 5022685



Insert strip, white, Unlabeled, Mounting type: Insert, Lettering field: 35 x 500 mm

Module marker carrier - PMB - 1004364



Phoenix module marker carrier, for labeling modules and PCBs, for hole diameter 3.9 to 4.1 mm, thickness of wall or board 1.5 - 2.0 mm, labeling with insert strips ESL, EST or ES/LP-BW-GB, lettering field: 29 x 8 mm

Electronic housing - UM122-PROFIL 235CM - 2735438

Accessories

Insert strip - AP-ES - 5022685



Insert strip, white, Unlabeled, Mounting type: Insert, Lettering field: 35 x 500 mm

Marker pen - B-STIFT - 1051993



Marker pen, for manual labeling of unprinted Zack strips, smear-proof and waterproof, line thickness 0.5 mm

Drawings

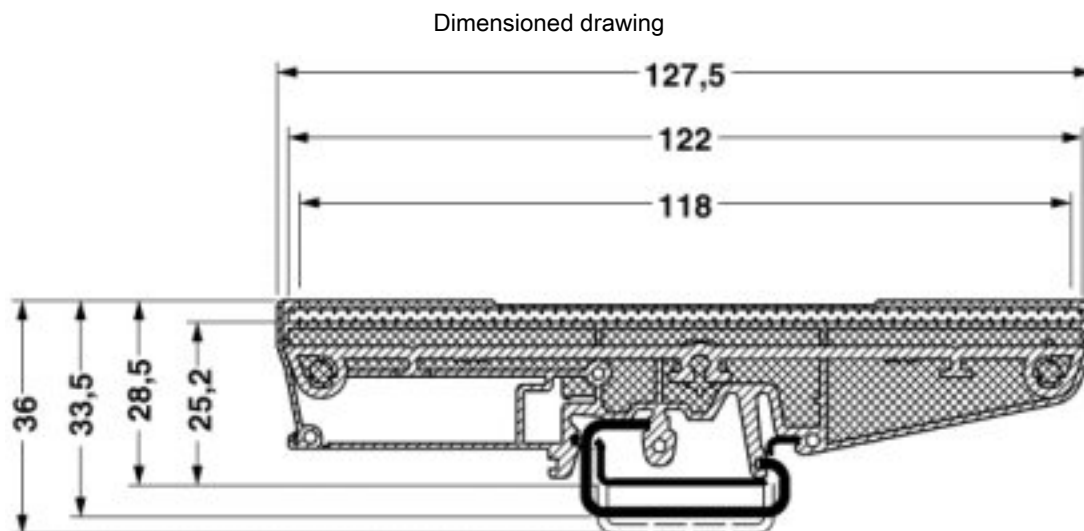

Electronic housing - UM122-PROFIL 235CM - 2735438

Dimensioned drawing

