



Chipsmall Limited consists of a professional team with an average of over 10 year of expertise in the distribution of electronic components. Based in Hongkong, we have already established firm and mutual-benefit business relationships with customers from,Europe,America and south Asia,supplying obsolete and hard-to-find components to meet their specific needs.

With the principle of “Quality Parts,Customers Priority,Honest Operation,and Considerate Service”,our business mainly focus on the distribution of electronic components. Line cards we deal with include Microchip,ALPS,ROHM,Xilinx,Pulse,ON,Everlight and Freescale. Main products comprise IC,Modules,Potentiometer,IC Socket,Relay,Connector.Our parts cover such applications as commercial,industrial, and automotives areas.

We are looking forward to setting up business relationship with you and hope to provide you with the best service and solution. Let us make a better world for our industry!



Contact us

Tel: +86-755-8981 8866 Fax: +86-755-8427 6832

Email & Skype: info@chipsmall.com Web: www.chipsmall.com

Address: A1208, Overseas Decoration Building, #122 Zhenhua RD., Futian, Shenzhen, China



FLM DIO 4/4 M12-2A

Fieldline Modular Device With Four Digital Inputs and Four Digital Outputs

Data Sheet 697200

02/2004



This data sheet is only valid in association with the FLS FLM SYS INST UM E user manual or the Fieldline user manual for your bus system (see "Ordering Data" on page 15).

Function

The device is designed for use in the Fieldline modular local bus, which is opened by a Fieldline modular bus coupler. It is used to acquire and output digital signals.

Features

- Connection to the Fieldline modular local bus using M12 connectors (B-encoded)
- Connection of digital sensors using M12 connectors
- Connection of digital actuators using M12 connectors, each with a load capacity of 2 A (nominal current)
- Flexible voltage supply concept
- LED diagnostic and status indicators
- Short-circuit and overload protection of outputs and sensor supply
- IP65/IP67 protection

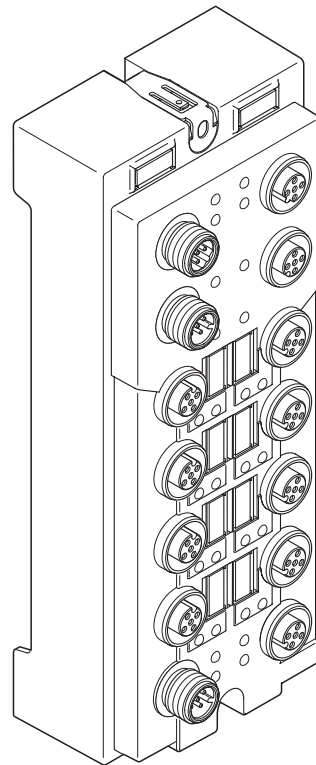

6972A001

Figure 1 The FLM DIO 4/4 M12-2A Fieldline device

Connections

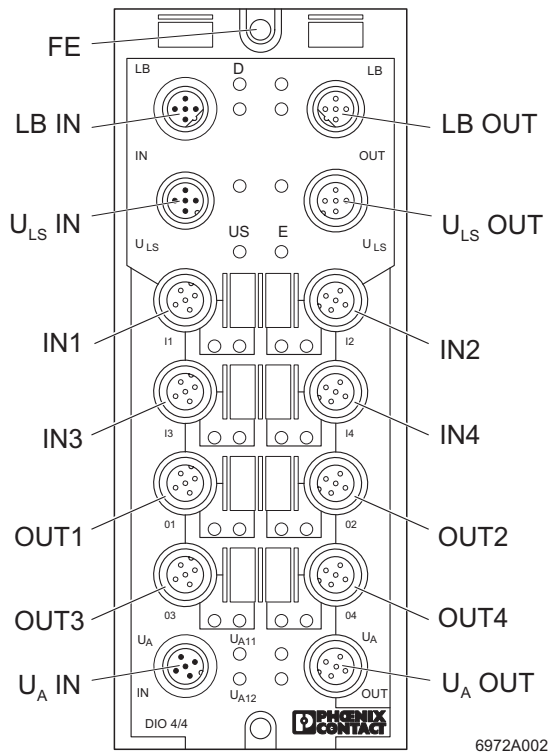

Figure 2 Connections of the FLM DIO 4/4 M12-2A

Des.	Meaning
FE	Functional earth ground
LB IN	Local bus IN
LB OUT	Local bus OUT
U _{LS} IN	Voltage supply IN (logic and sensor supply)
U _{LS} OUT	Voltage supply OUT (logic and sensor supply) for additional devices
IN1 to IN4	Inputs 1 to 4
OUT1 to OUT4	Outputs 1 to 4
U _A IN	Voltage supply IN of the outputs (OUT1 to OUT4) with voltages U _{A11} and U _{A12}
U _A OUT	Voltage supply OUT of the outputs for other devices



In general, the maximum current load of 4 A per contact must not be exceeded.

Pin Assignment of LB IN/LB OUT

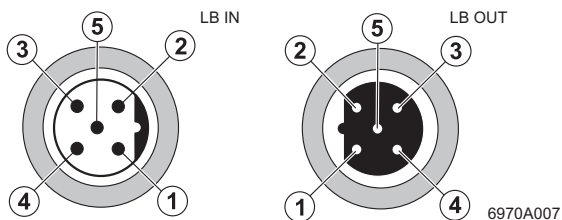

Figure 3 Pin assignment of LB IN/LB OUT (M12 B-encoded)

Pin	LB IN	LB OUT
1	DO	DO
2	$\overline{\text{DO}}$	$\overline{\text{DO}}$
3	DI	DI
4	$\overline{\text{DI}}$	$\overline{\text{DI}}$
5	GND	GND



The thread is used for shielding.

Pin Assignment of the Voltage Supply U_{LS}

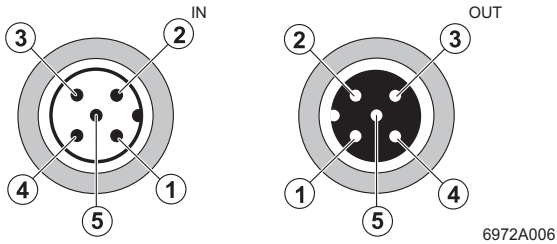

Figure 4 Pin assignment of the voltage supply U_{LS}

Pin	IN	OUT
1	$U_L +24\text{ V}$	$U_L +24\text{ V}$
2	$U_S\text{ GND}$	$U_S\text{ GND}$
3	$U_L\text{ GND}$	$U_L\text{ GND}$
4	$U_S +24\text{ V}$	$U_S +24\text{ V}$
5	500 kbaud/ 2 Mbaud	500 kbaud/ 2 Mbaud



The transmission speed is switched at the bus coupler.

Pin Assignment of the Voltage Supply U_A of the Outputs

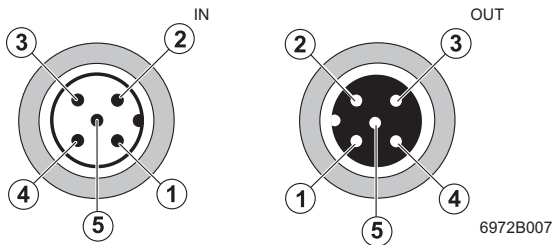

Figure 5 Pin assignment of the voltage supply U_A of the outputs

Pin	IN	OUT
1	$U_{A11} +24\text{ V}$	$U_{A11} +24\text{ V}$
2	$U_{A12}\text{ GND}$	$U_{A12}\text{ GND}$
3	$U_{A11}\text{ GND}$	$U_{A11}\text{ GND}$
4	$U_{A12} +24\text{ V}$	$U_{A12} +24\text{ V}$
5	Not used	Not used

Pin Assignment of the Inputs and Outputs

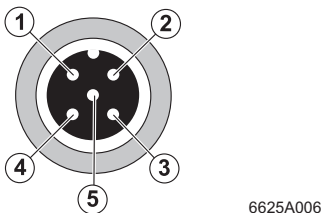

Figure 6 Pin assignment of the inputs and outputs

Pin	Input Socket	Output Socket
1	$U_S +24\text{ V}$	Not used
2	See Figure 7	Not used
3	GND	GND
4	Input	Output
5	FE	FE

Assignment of the Input Sockets

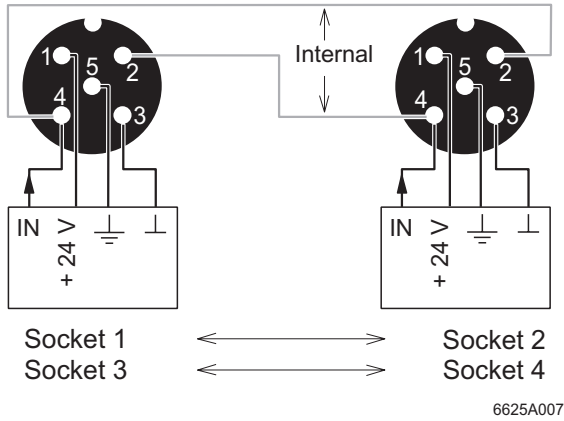

Figure 7 Assignment of the input sockets



Two input signals can be connected to each input socket. If both inputs of the same socket are used, the other socket must not be used (1 or 2 and 3 or 4) (see Figure 7).

Local LED Diagnostic and Status Indicators

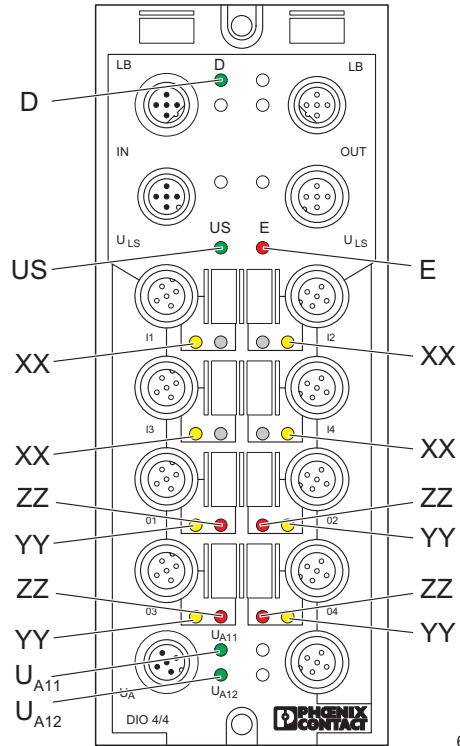

Figure 8 LED diagnostic and status indicators of the FLM DIO 4/4 M12-2A

Des.	Color	Meaning
D	Green LED	Diagnostics
	ON:	Bus active
	Flashing, 0.5 Hz:	Communications power present, bus not active
	Flashing, 2 Hz:	Communications power present, bus active, I/O error
	Flashing, 4 Hz:	Communications power present, device to the left of the flashing device failed; devices to the right of the flashing device are not part of the configuration frame
	OFF:	Communications power not present, bus not active
US	Green LED	Voltage supply for IN1 to IN4
	ON:	Voltage supply present
	OFF:	Voltage supply too low
E	Red LED	Overload of voltage supply U_S
	ON:	Voltage supply overloaded
	OFF:	Voltage supply not overloaded
XX	Yellow LED	Status indicators of the inputs
	ON:	Input active
	OFF:	Input not active
YY	Yellow LED	Status indicators of the outputs
	ON:	Output active
	OFF:	Output not active
ZZ	Red LED	Overload of the outputs
	ON:	Output overloaded
	OFF:	Output not overloaded
UA11	Green LED	Voltage supply for OUT1 and OUT2
	ON:	Voltage supply for OUT1 and OUT2 present
	OFF:	Voltage supply for OUT1 and OUT2 too low
UA12	Green LED	Voltage supply for OUT3 and OUT4
	ON:	Voltage supply for OUT3 and OUT4 present
	OFF:	Voltage supply for OUT3 and OUT4 too low

Internal Circuit Diagram

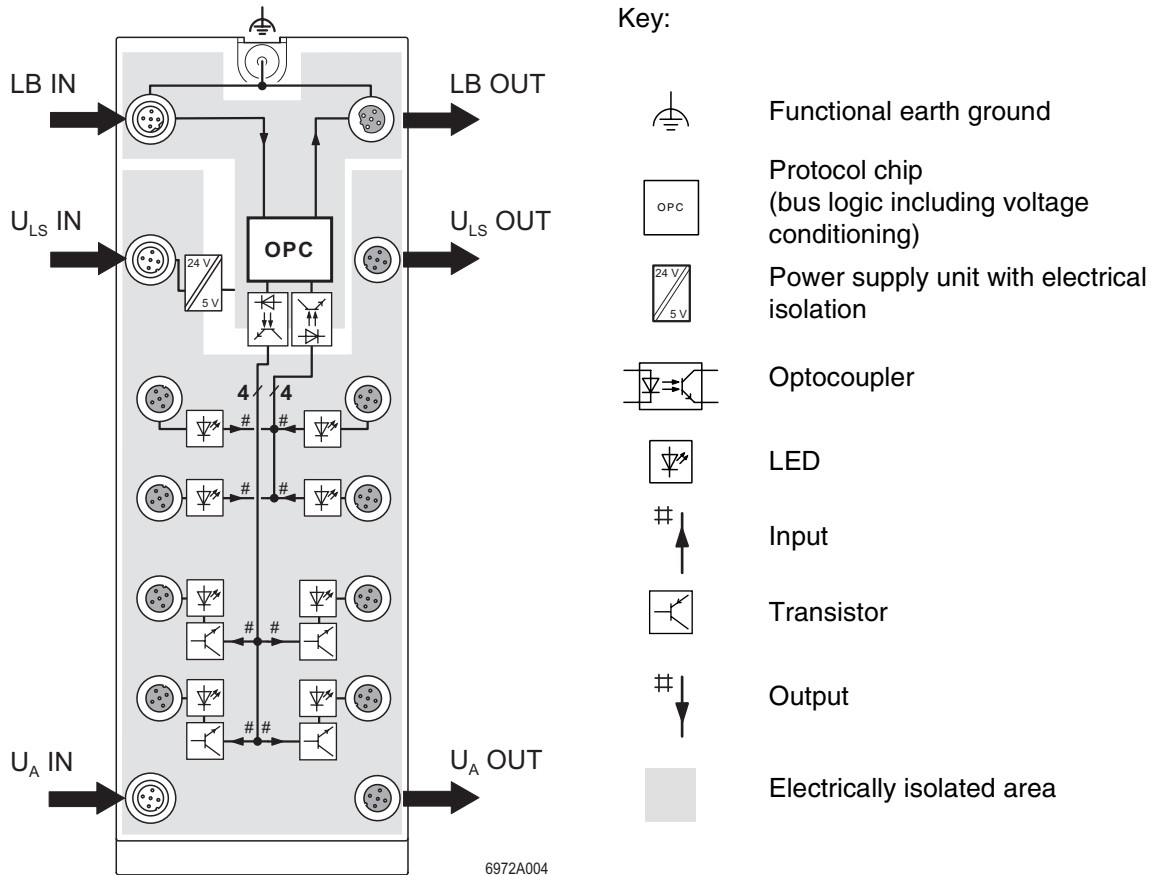
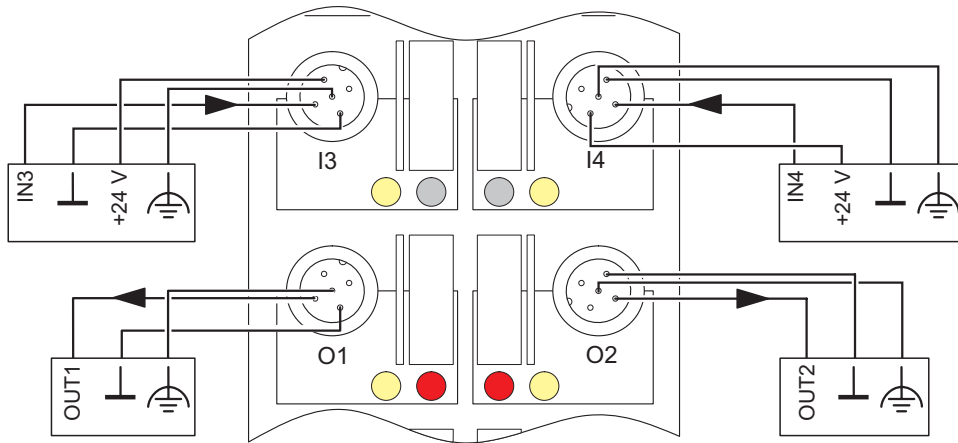

Figure 9 Internal wiring of the connection points



For information on electrically isolated areas, please refer to page 15.

Connection Example



6625B009

Figure 10 Typical connection of sensors and actuators

Connection Notes



Meet noise immunity requirements

Connect FE using a mounting screw or a cable connection to the FE connection latch (when mounting on a non-conductive surface).



Ensure degree of protection

To ensure IP65/IP67 protection, cover unused sockets with protective caps.



Avoid damage to the electronics

Make sure you only supply the sensors with the voltage U_S provided at the connection points.



Avoid polarity reversal

Avoid polarity reversal of the supply voltages U_L , U_S , and U_A in order to prevent damage to the device.



Observe connection point assignment

When connecting the sensors and actuators, observe the assignment of the connection points to the IN and OUT process data (see "Process Data" on page 8).

Programming Data/Configuration Data

INTERBUS

ID code	BF _{hex} (191 _{dec})
Length code	41 _{hex}
Process data channel	4 bits
Input address area	4 bits
Output address area	4 bits
Parameter channel (PCP)	0 bits
Register length (bus)	4 bits

Other Bus Systems



For the programming data of other bus systems, please refer to the appropriate electronic device data sheet (GSD, EDS). For additional information, please refer to the user manuals, see "Ordering Data" on page 15.

Process Data

Assignment of the Connection Points to the IN Process Data

(Byte.bit) view	Bit	0.3	0.2	0.1	0.0
Device	Input	4	3	2	1

Assignment of the Connection Points to the OUT Process Data

(Byte.bit) view	Bit	0.3	0.2	0.1	0.0
Device	Output	4	3	2	1





For the assignment of the illustrated (byte.bit) view for your INTERBUS control or computer system, please refer to data sheet DB GB IBS SYS ADDRESS, Part No. 90 00 99 0.

Technical Data

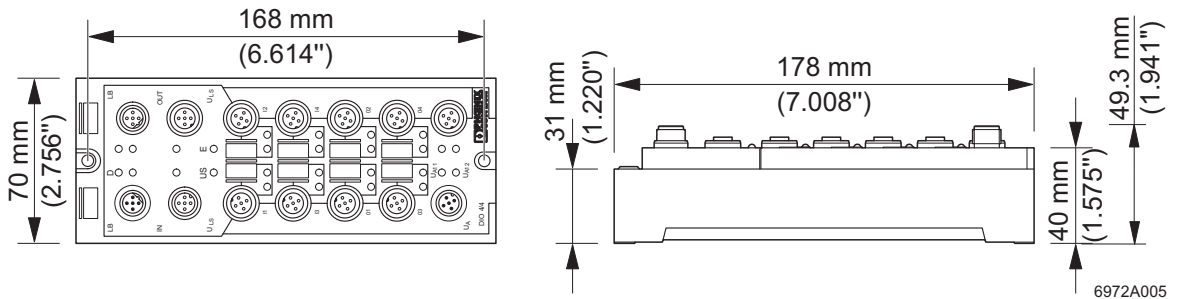
Device Dimensions



General Data	
Order designation	FLM DIO 4/4 M12-2A
Order no.	27 36 36 9
Housing dimensions (width x height x depth)	70 mm x 178 mm x 49.3 mm (2.756 x 7.008 x 1.941 in.)
Weight	315 g, approximately
Operating mode	Process data mode with 4 bits
Transmission speed	500 kbaud/2 Mbaud
Type of sensor connection	2, 3 or 4-wire technology
Type of actuator connection	2 or 3-wire technology
Permissible temperature (operation)	-25°C to +60°C (-13°F to +140°F)
Permissible temperature (storage/transport)	-25°C to +85°C (-13°F to +185°F)
Permissible humidity (storage/transport)	95%
 For a short period, slight condensation may appear on the housing.	
Permissible air pressure (operation)	80 kPa to 106 kPa (up to 2000 m [6562 ft.] above sea level)
Permissible air pressure (storage/transport)	70 kPa to 106 kPa (up to 3000 m [9843 ft.] above sea level)
Degree of protection	IP65/IP67 according to IEC 60529
Class of protection	Class 3 according to VDE 0106, IEC 60536

Mechanical Requirements	
Vibration test Sinusoidal vibrations according to EN 60068-2-6	5g load in each space direction
Shock test according to EN 60068-2-27	30g load, half sinusoidal wave positive and negative in each space direction
	For additional information on mechanical requirements and ambient conditions, please contact Phoenix Contact.

Voltage Supply	
Nominal value	24 V DC
Tolerance	±25%
Current consumption at U_L at 24 V DC	
At 500 kbaud	40 mA, typical (50 mA, maximum)
At 2 Mbaud	45 mA, typical (50 mA, maximum)
Current consumption at U_S at 24 V DC	5 mA, typical, + sensor current (600 mA, maximum)
Current consumption at U_{Axx} at 24 V DC	3 mA, typical, + actuator current (4 A, maximum)

Digital Inputs	
Number	4
Input design	According to IEC 61131-2 Type 1
Definition of switching thresholds	
Maximum low level voltage	$U_{Lmax} < 5 \text{ V}$
Minimum high level voltage	$U_{Hmin} > 11 \text{ V}$
Nominal input voltage	24 V DC
Range	$-30 \text{ V DC} < U_{IN} < +30 \text{ V DC}$
Nominal input current	5 mA
Current flow	Linear in the range $2 \text{ V} < U_{IN} < 30 \text{ V}$
Delay time	$t_{ON} = 3.1 \text{ ms}$, typical $t_{OFF} = 4.1 \text{ ms}$, typical
Permissible cable length to the sensor	< 30 m (98.43 ft.)



Input Characteristic Curve	
Input Voltage (V)	Typical Input Current (mA)
$-30 < U_{IN} < 0.7$	0
3	0.5
6	1.0
9	1.6
12	2.3
15	3.0
18	3.8
21	4.5
24	5.2
27	6.0
30	6.7



Sensor Supply	
Minimum sensor voltage	$U_S - 1 \text{ V}$
Nominal current per channel	600 mA
Nominal current per device	600 mA
Overload protection	Electronic per device
Short-circuit protection	Electronic per device

Error Messages to the Higher-Level Control or Computer System	
Sensor supply short-circuit	Yes
Sensor supply overload	Yes

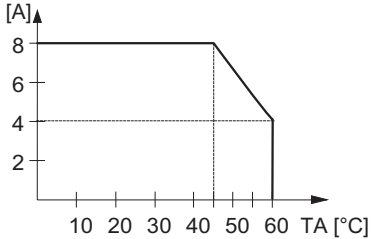

If an error is triggered by an overload or short circuit of the sensor supply, the device switches off the sensor supply of the channels and reports an I/O error message to the master.

Digital Outputs							
Number	4						
Nominal output voltage U_{OUT}	$U_{Axx} - 1 V$						
Differential voltage for I_{nom}	$\leq 1 V$						
Nominal current I_{nom} per channel	2 A						
Total current	8 A (observe derating)						
Protection	Short circuit; overload						
	Single chip structure, i.e., all channels are thermally isolated. An error in one channel can affect the other channels. The outputs have separate overload protection.						
Derating at 100% simultaneity	 <p style="text-align: right;">6625B011</p>						
	At an ambient temperature of 45°C (113°F) or higher, voltages U_L and U_S at socket U_{LS} OUT can each only carry a maximum current of 2 A.						
Nominal load per channel	<table border="0"> <tr> <td>– Ohmic</td> <td>48 W</td> </tr> <tr> <td>– Inductive</td> <td>48 VA (1.2 H, 12 Ω)</td> </tr> <tr> <td>– Lamp</td> <td>48 W</td> </tr> </table>	– Ohmic	48 W	– Inductive	48 VA (1.2 H, 12 Ω)	– Lamp	48 W
– Ohmic	48 W						
– Inductive	48 VA (1.2 H, 12 Ω)						
– Lamp	48 W						
Signal delay upon power up	Approximately 140 μs , typical						
Signal delay upon power down	Approximately 3.4 ms, typical						
	The behavior of the output voltage depends on the switched load.						

Digital Outputs (Continued)	
Switching frequency with	
– Nominal ohmic load	500 Hz, maximum
	This switching frequency is limited by the number of bus devices, the bus structure, the software, and the control or computer system used.
– Nominal inductive load	0.1 Hz (1.2 H, 12 Ω), maximum
– Nominal lamp load	500 Hz, maximum
Overload response	Auto restart
Restart frequency with ohmic overload (2 Ω)	45 Hz, approximately
Response with inductive overload	Output may be damaged
Reverse voltage protection against short pulses	Protected against reverse voltages
Resistance to permanently applied reverse voltages	No
Response upon power down	The output follows the supply voltage without delay.
Validity of output data after connecting the voltage supply (power up)	5 ms, typical
Limitation of the voltage induced on circuit interruption	-11 V, approximately
Single maximum energy in free running	1500 W
Protective circuit type	Integrated free-wheeling diode for each channel
Overcurrent shutdown	2.6 A, minimum
Output current when switched off	20 μA, maximum
Output current with ground connection interrupt when switched off	5 mA, maximum
Error Messages	
Overload of outputs	Yes
	If an error is triggered at the outputs due to an overload, the device switches off the corresponding output and sends an error to the master.
Permissible cable length to the actuator	< 30 m (98.43 ft.)

Output Characteristic Curve When Switched On (Typical)	
Output Current (A)	Differential Output Voltage (V)
0	0
0.20	0.01
0.40	0.03
0.75	0.05
1.00	0.07
1.50	0.12
1.75	0.13
2.00	0.17

Output Characteristic Curve for Ground Connection Interrupt ($U_{Axx} = 30 \text{ V DC}$)	
Load Resistance (k Ω)	Output Voltage (V)
∞	29.9
1000	28.8
100	25.0
10	13.6
1	3.8

Interface	
Bus system	Fieldline modular local bus
Incoming Bus	
Coupling of shield connection	Directly to FE
Transmission speed	500 kbaud/2 Mbaud
Outgoing Bus	
Coupling of shield connection	Directly to FE
Transmission speed	500 kbaud/2 Mbaud

Electrical Isolation/Isolation of the Voltage Areas

For device connection, please note the instructions and regulations in the "Installing the Fieldline Product Range" user manual FLS FLM SYS INST UM E (Order No. 26 98 97 3).

Separate Potentials in the FLM DIO 4/4 M12-2A

- Test Distance	- Test Voltage
24 V supply (bus logic) / FE	500 V AC, 50 Hz, 1 min
24 V supply (bus logic) / digital inputs (sensor supply / I/O)	500 V AC, 50 Hz, 1 min
24 V supply (bus logic) / digital outputs (actuator supply)	500 V AC, 50 Hz, 1 min
24 V supply (bus logic) / local bus	500 V AC, 50 Hz, 1 min
Digital inputs (sensor supply / I/O) / FE	500 V AC, 50 Hz, 1 min
Digital inputs (sensor supply / I/O) / digital outputs (actuator supply)	500 V AC, 50 Hz, 1 min
Digital inputs (sensor supply / I/O) / local bus	500 V AC, 50 Hz, 1 min
Digital outputs (actuator supply) / FE	500 V AC, 50 Hz, 1 min
Digital outputs (actuator supply) / local bus	500 V AC, 50 Hz, 1 min
Local bus / FE	500 V AC, 50 Hz, 1 min

Ordering Data

Description	Order Designation	Order No.
Fieldline modular device with four digital inputs and four digital outputs	FLM DIO 4/4 M12-2A	27 36 36 9
Protective caps (for unused sockets) pack of 5	IBS IP PROT-IO	27 59 91 9
Protective caps (for unused connectors) pack of 5	PROT-M12-M	27 36 19 4
Shielded connector, 5-pos. female connector, B-encoded, for the incoming local bus	SACC-M12FSB-5SC SH	15 13 59 6
Shielded connector, 5-pos. male connector, B-encoded, for the outgoing local bus	SACC-M12MSB-5SC SH	15 13 57 0
Markers pack of 10	ZBF 12:UNBEDRUCKT	08 09 73 5

Description	Order Designation	Order No.
"Installing the Fieldline Product Range" user manual	FLS FLM SYS INST UM E	26 98 97 3
"Configuring an INTERBUS System Using Devices in the Fieldline Product Range" user manual	FLS FLM IB SYS PRO UM E	26 99 06 6
"Configuring a PROFIBUS DP System Using Devices in the Fieldline Product Range" user manual	FLS FLM PB SYS PRO UM E	26 99 07 9
"Configuring a DeviceNet™ System Using Devices in the Fieldline Product Range" user manual	FLS FLM DN SYS PRO UM E	26 99 08 2
"Configuring a CANopen System Using Devices in the Fieldline Product Range" user manual	FLS FLM CO SYS PRO UM E	26 99 09 5
Additional accessories for connecting the sensors and actuators can be found in the Phoenix Contact PLUSCON catalog.		



Make sure you always use the latest documentation.
It can be downloaded at www.phoenixcontact.com.

Phoenix Contact GmbH & Co. KG
 Flachsmarktstr. 8
 32825 Blomberg
 Germany



+49 - 52 35 - 30 0



+49 - 52 35 - 34 12 00



www.phoenixcontact.com



Worldwide Locations:

www.phoenixcontact.com/salesnetwork