



Chipsmall Limited consists of a professional team with an average of over 10 year of expertise in the distribution of electronic components. Based in Hongkong, we have already established firm and mutual-benefit business relationships with customers from,Europe,America and south Asia,supplying obsolete and hard-to-find components to meet their specific needs.

With the principle of “Quality Parts,Customers Priority,Honest Operation,and Considerate Service”,our business mainly focus on the distribution of electronic components. Line cards we deal with include Microchip,ALPS,ROHM,Xilinx,Pulse,ON,Everlight and Freescale. Main products comprise IC,Modules,Potentiometer,IC Socket,Relay,Connector.Our parts cover such applications as commercial,industrial, and automotives areas.

We are looking forward to setting up business relationship with you and hope to provide you with the best service and solution. Let us make a better world for our industry!



## Contact us

Tel: +86-755-8981 8866 Fax: +86-755-8427 6832

Email & Skype: info@chipsmall.com Web: www.chipsmall.com

Address: A1208, Overseas Decoration Building, #122 Zhenhua RD., Futian, Shenzhen, China



# PB IL 24 BK DIO 16/16

## PROFIBUS-DP/V1 Bus Coupler Station With 16 Digital Inputs and 16 Digital Outputs

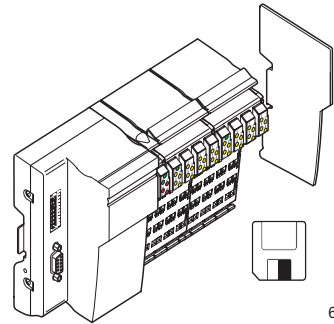

Data Sheet 643701

07/2003

6437B002



This data sheet is only valid in association with the "Configuring and Installing the PROFIBUS-DP/V1 bus coupler for the Inline Product Range" User Manual, IL PB BK DP/V1 UM E.



A detailed description of the PROFIBUS-DP/V1 bus coupler (IL PB BK DP/V1) and the input/output modules IB IL 24 DI 16 and IB IL 24 DO 16 can be found in the relevant data sheets (see "Ordering Data for Documentation" on page 5).

## Function

PB IL 24 BK DIO 16/16 is a complete Inline station, which consists of the components shown in Figure 1 on page 2.

The PROFIBUS-DP/V1 bus coupler is the link between PROFIBUS-DP and the Inline installation system. Inline modules can be connected in any position to an existing PROFIBUS-DP system using the PROFIBUS-DP/V1 bus coupler. In this way, all the advantages of the installation system created by these modules can be used on PROFIBUS.

The station can be expanded with additional Inline modules, AS-i modules or INTERBUS Loop 2 modules.

## Station Components

The station consists of the following components (supplied as standard):

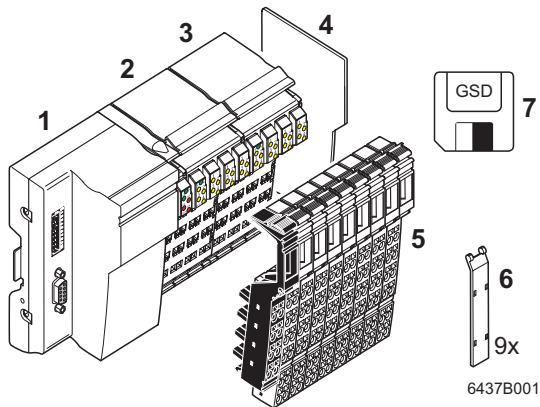

Figure 1 PB IL 24 BK DIO 16/16 module

- 1 PROFIBUS-DP/V1 bus coupler (IL PB BK DP/V1)
  - For the connection of the Inline station to PROFIBUS-DP
  - For the provision of the supply voltage for the connected devices
- 2 IB IL 24 DO 16 module for the output of 16 digital output signals
- 3 IB IL 24 DI 16 module for the acquisition of 16 digital input signals
- 4 End plate

Place this plate at the end of the Inline station. The end plate does not have any electrical function. It protects the station against ESD pulses and the user against dangerous contact voltage.

- 5 Connector
- 6 Labeling fields
- 7 Disk with device database file (GSD)

The disk contains the device database file (GSD) required by PROFIBUS and a bitmap file with an icon of the coupler and connected Inline modules.



An up-to-date device database file can be downloaded from the Internet at [www.phoenixcontact.com](http://www.phoenixcontact.com).

## Features of the PROFIBUS-DP/V1 Fieldbus Coupler IL PB BK DP/V1

(\*) new functions in the IL PB BK-compatible mode

- A maximum of 63 Inline devices or Loop 2 modules can be connected to PROFIBUS-DP via the bus coupler. The PROFIBUS-DP/V1 bus coupler and the Inline terminals create a station.
- The total of all input and output data of the connected terminals must not exceed 176 bytes per station in the IL PB BK DP/V1 mode (DIP switch 8 = ON).  
(184 bytes in the IL PB BK mode, DIP switch 8 = OFF)
- DP/V1 for Class 1 and Class 2 masters
- Acyclic communication with, e.g., RS-232 modules also in the process data channel (\*)
- I/O module parameterization
- Failsafe values
- Various diagnostic formats
- Acknowledgment of I/O errors from the user program (\*)
- Adaptation of the high byte/low byte format in 16-channel input and output modules to the control system format (\*)
- The bus coupler can be installed with a data transmission speed of 9.6 kbps to 12 Mbps. The bus coupler is automatically set to the speed specified by the PROFIBUS master.
- The operating voltage of the bus coupler is 24 V DC. The operating temperature range is 0°C to 55°C (32°F to 131°F).
- Diagnostics is provided locally by LEDs on the bus coupler, and on the Inline terminals and Loop 2 modules. All diagnostic information can be forwarded to the PROFIBUS master via PROFIBUS.

The intelligent wiring method used in the Inline terminals and Loop 2 modules enables the stations to be constructed quickly and easily because, for example, there is no need for time-consuming wiring of terminal power supplies. In the simplest case, it is only necessary for the power supply units integrated in the PROFIBUS-DP/V1 bus coupler to be supplied with 24 V DC. They then generate the operating voltage required for the PROFIBUS-DP/V1 bus coupler and the connected Inline terminals.

DIP switch 8 is particularly important, see IL PB BK DP/V1 (-PAC) data sheet. As default upon delivery, it is in the "OFF" position. This means that the device can directly replace the previous version IL PB BK (Order No. 27 40 05 4) although it also offers some new functions, see above (\*). However, these functions can only be used on the new devices. When configuring the device, use the "PXC\_00F0.GSD" GSD and the "IL PB BK DP/V1 (DIP 8 = OFF)" device entry in the hardware list.

In the "ON" position, the device offers all the above functions and has a new PROFIBUS ID number. It should therefore be configured and parameterized using the "PXC\_06CC.GSD" GSD and the "IL PB BK DP/V1 (DIP 8 = ON)" device entry in the hardware list. The stop response, which was specified by this switch in the old device, is then set upon parameterization.



For a detailed description, please refer to the PROFIBUS-DP/V1 bus coupler data sheet (see "Ordering Data for Documentation" on page 5).

**Function of the IB IL 24 DO 16 Module**

The module is designed for use within an Inline station. It is used to output digital signals.

**Features of the IB IL 24 DO 16 Module**

- Connections for 16 digital actuators
- Connection of actuators in 2 and 3-wire technology
- Nominal current of each output: 0.5 A
- Total current of the module: 8 A
- Short-circuit and overload protected outputs
- Diagnostics and status indicators

**Function of the IB IL 24 DI 16 Module**

The module is designed for use within an Inline station. It is used to acquire digital input signals.

**Features of the IB IL 24 DI 16 Module**

- Connections for 16 digital sensors
- Connection of sensors in 2 and 3-wire technology
- Maximum permissible load current per sensor: 250 mA
- Maximum permissible load current from the module: 4.0 A
- Diagnostics and status indicators

## Ordering Data

Description	Order Designation	Order No.
PROFIBUS-DP/V1 bus coupler station with 16 digital inputs and 16 digital outputs (including connectors, labeling fields, end plate and disk with GSD file)	PB IL 24 BK DIO 16/16	27 42 63 8
<b>Ordering Data for Documentation</b>		
Data sheet for PROFIBUS-DP/V1 bus coupler	DB GB IL PB BK DP/V1 (-PAC)	90 13 61 3
Data sheet for Inline module with 16 digital outputs	DB GB IB IL 24 DO 16 (-PAC)	94 23 25 1
Data sheet for Inline module with 16 digital inputs	DB GB IB IL 24 DI 16 (-PAC)	94 23 18 3
Configuring and Installing the PROFIBUS-DP/V1 Bus Coupler for the Inline Product Range	IL PB BK DP/V1 UM E	26 98 10 6
CD-ROM with all Inline, INTERBUS Loop 2, and other data sheets	CD IBS DB ELDOC	27 45 60 6



Ensure that you are always working with the latest documentation published. It can be downloaded at [www.phoenixcontact.com](http://www.phoenixcontact.com).

Phoenix Contact GmbH & Co. KG  
 Flachsmarktstr. 8  
 32825 Blomberg  
 Germany



+ 49 - (0) 52 35 - 3-00



+ 49 - (0) 52 35 - 3-4 12 00



[www.phoenixcontact.com](http://www.phoenixcontact.com)



Worldwide Locations:

[www.phoenixcontact.com/salesnetwork](http://www.phoenixcontact.com/salesnetwork)