



Chipsmall Limited consists of a professional team with an average of over 10 year of expertise in the distribution of electronic components. Based in Hongkong, we have already established firm and mutual-benefit business relationships with customers from,Europe,America and south Asia,supplying obsolete and hard-to-find components to meet their specific needs.

With the principle of “Quality Parts,Customers Priority,Honest Operation,and Considerate Service”,our business mainly focus on the distribution of electronic components. Line cards we deal with include Microchip,ALPS,ROHM,Xilinx,Pulse,ON,Everlight and Freescale. Main products comprise IC,Modules,Potentiometer,IC Socket,Relay,Connector.Our parts cover such applications as commercial,industrial, and automotives areas.

We are looking forward to setting up business relationship with you and hope to provide you with the best service and solution. Let us make a better world for our industry!



Contact us

Tel: +86-755-8981 8866 Fax: +86-755-8427 6832

Email & Skype: info@chipsmall.com Web: www.chipsmall.com

Address: A1208, Overseas Decoration Building, #122 Zhenhua RD., Futian, Shenzhen, China



Housing - UEGM 27,5-SMD - 2757063

Please be informed that the data shown in this PDF Document is generated from our Online Catalog. Please find the complete data in the user's documentation. Our General Terms of Use for Downloads are valid (<http://phoenixcontact.com/download>)



Electronic housing, for PCB insertion, fully equipped with 3 screw connections per side, for mounting of SMD components

Illustration shows version UEGM 22.5

Product Features

- Cost-effective series production, since the base element and the assembled PCB are soldered by machine
- Efficient assembly thanks to overlapping housing parts
- Can be snapped onto standard NS 35/7,5 and NS 35/15 DIN rails
- Complex electronic circuits can be integrated, with up to 24 connections on two levels



Key commercial data

Packing unit	1 pc
Weight per Piece (excluding packing)	57.75 GRM
Custom tariff number	85369010
Country of origin	Germany

Technical data

General

Housing type	Complete housing
Housing material	Polyamide (PA 6.6)
Color	green

Ambient conditions

Ambient temperature (operation)	-40 °C ... 105 °C
---------------------------------	-------------------

Dimensions

Length	79 mm
Constructional height	85.5 mm

Housing - UEGM 27,5-SMD - 2757063

Technical data

Dimensions

Width	27.5 mm
Pitch	5 mm

Technical data

Inflammability class according to UL 94	V0
Number of positions	6

Connection data

Conductor cross section solid min.	0.2 mm ²
Conductor cross section solid max.	4 mm ²
Conductor cross section stranded min.	0.2 mm ²
Conductor cross section stranded max.	2.5 mm ²
Conductor cross section AWG/kcmil min.	24
Conductor cross section AWG/kcmil max	12
Stripping length	8 mm

Classifications

eCl@ss

eCl@ss 4.0	27180401
eCl@ss 4.1	27180401
eCl@ss 5.0	27180506
eCl@ss 5.1	27180506
eCl@ss 6.0	27180802
eCl@ss 7.0	27182702
eCl@ss 8.0	27182702

ETIM

ETIM 2.0	EC001031
ETIM 3.0	EC001031
ETIM 4.0	EC001031
ETIM 5.0	EC001031

UNSPSC

UNSPSC 6.01	31261501
UNSPSC 7.0901	31261501
UNSPSC 11	31261501
UNSPSC 12.01	31261501
UNSPSC 13.2	31261501

Housing - UEGM 27,5-SMD - 2757063

Approvals

Approvals

Approvals

UL Recognized / GOST / GOST

Ex Approvals

Approvals submitted

Approval details

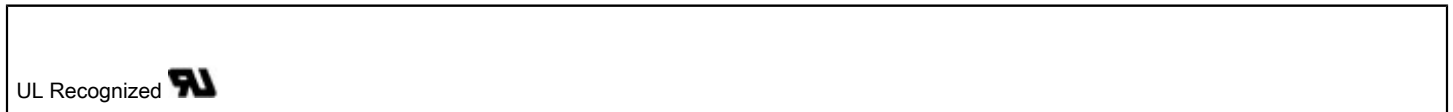

Drawings

Explosion drawing

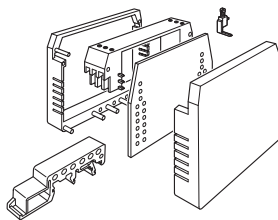

Dimensioned drawing

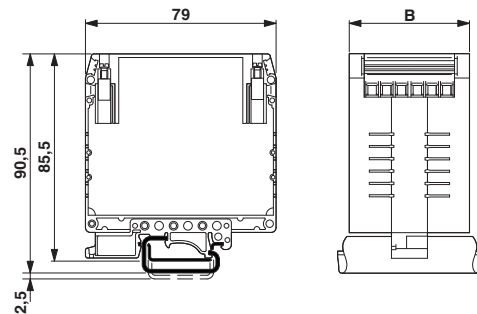

Housing - UEGM 27,5-SMD - 2757063

Dimensioned drawing

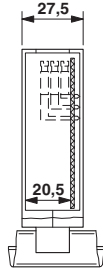

UEGM 25... und UEGM 27,5-SMD with 1 PCB, 6 positions or 12 positions (FS/FS)

Dimensioned drawing

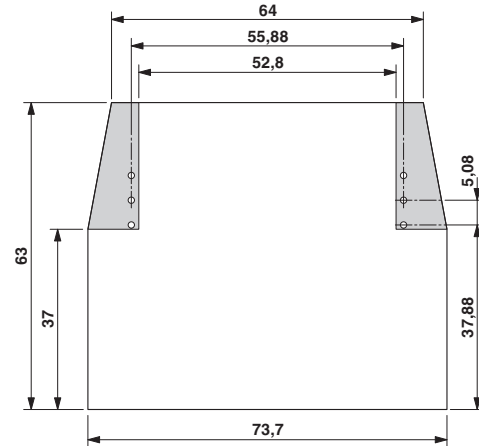

Schematic diagram

