



Chipsmall Limited consists of a professional team with an average of over 10 year of expertise in the distribution of electronic components. Based in Hongkong, we have already established firm and mutual-benefit business relationships with customers from,Europe,America and south Asia,supplying obsolete and hard-to-find components to meet their specific needs.

With the principle of “Quality Parts,Customers Priority,Honest Operation,and Considerate Service”,our business mainly focus on the distribution of electronic components. Line cards we deal with include Microchip,ALPS,ROHM,Xilinx,Pulse,ON,Everlight and Freescale. Main products comprise IC,Modules,Potentiometer,IC Socket,Relay,Connector.Our parts cover such applications as commercial,industrial, and automotives areas.

We are looking forward to setting up business relationship with you and hope to provide you with the best service and solution. Let us make a better world for our industry!



## Contact us

Tel: +86-755-8981 8866 Fax: +86-755-8427 6832

Email & Skype: info@chipsmall.com Web: www.chipsmall.com

Address: A1208, Overseas Decoration Building, #122 Zhenhua RD., Futian, Shenzhen, China



## Electronic housing - UEGH 45/2-SMD - 2757173

Please be informed that the data shown in this PDF Document is generated from our Online Catalog. Please find the complete data in the user's documentation. Our General Terms of Use for Downloads are valid (<http://phoenixcontact.com/download>)



Electronic housing, double-level, fully equipped with 12 screw connections per side for two printed circuit boards, for mounting of SMD components

The illustration shows version UEGH 40/1

### Product Features

- ✓ Efficient assembly thanks to overlapping housing parts
- ✓ Increased number of positions thanks to optional UEGM-MT FS slip-on connections
- ✓ Can be snapped onto standard NS 35/7,5 and NS 35/15 DIN rails
- ✓ Can accommodate up to two PCBs



### Key commercial data

Packing unit	1 pc
GTIN	 4 017918 108038
Weight per Piece (excluding packing)	123.78 GRM
Custom tariff number	85369010
Country of origin	Germany

### Technical data

#### General

Housing type	Complete housing
Housing material	Polyamide (PA 6.6)
Color	green

#### Ambient conditions

Ambient temperature (operation)	-40 °C ... 105 °C
---------------------------------	-------------------

#### Dimensions

# Electronic housing - UEGH 45/2-SMD - 2757173

## Technical data

### Dimensions

Length	79 mm
Constructional height	106.7 mm
Width	45 mm
Pitch	5 mm

### Technical data

Connection in acc. with standard	CUL
Nominal voltage $U_N$	300 V
Nominal current $I_N$	10 A
AWG/kcmil	30-12
Indicator1	CUL1
Inflammability class according to UL 94	V0
Power dissipation at 20°C in the horizontal mounting position	6.5 W 9.8 W
Number of positions	24

### Connection data

Conductor cross section solid min.	0.2 mm <sup>2</sup>
Conductor cross section solid max.	4 mm <sup>2</sup>
Conductor cross section stranded min.	0.2 mm <sup>2</sup>
Conductor cross section stranded max.	2.5 mm <sup>2</sup>
Conductor cross section AWG/kcmil min.	24
Conductor cross section AWG/kcmil max	12
Stripping length	8 mm

## Classifications

### eCl@ss

eCl@ss 4.0	27180401
eCl@ss 4.1	27180401
eCl@ss 5.0	27180506
eCl@ss 5.1	27180506
eCl@ss 6.0	27180802
eCl@ss 7.0	27182702
eCl@ss 8.0	27182702

### ETIM

ETIM 2.0	EC001031
ETIM 3.0	EC001031

# Electronic housing - UEGH 45/2-SMD - 2757173

## Classifications

### ETIM

ETIM 4.0	EC001031
ETIM 5.0	EC001031

### UNSPSC

UNSPSC 6.01	31261501
UNSPSC 7.0901	31261501
UNSPSC 11	31261501
UNSPSC 12.01	31261501
UNSPSC 13.2	31261501

## Approvals

### Approvals

#### Approvals

UL Recognized / cUL Recognized / GOST / GOST / cULus Recognized

#### Ex Approvals

#### Approvals submitted

## Approval details

UL Recognized
---------------

cUL Recognized		
	B	D
mm <sup>2</sup> /AWG/kcmil	30-12	30-12
Nominal current I <sub>N</sub>	10 A	10 A
Nominal voltage U <sub>N</sub>	300 V	300 V

# Electronic housing - UEGH 45/2-SMD - 2757173

## Approvals

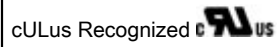

## Drawings

Dimensioned drawing

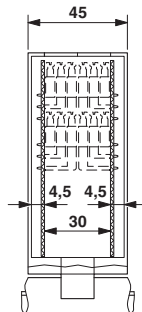

Dimensioned drawing

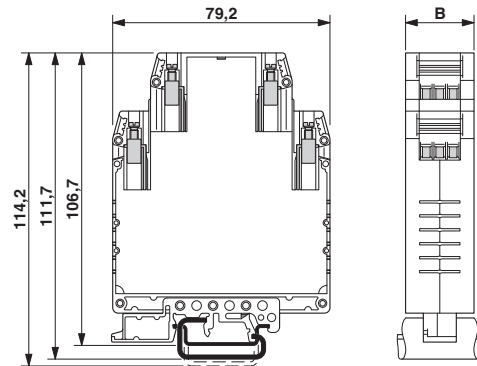

For 2 PCBs, for SMD assembly of reverse side of both PCBs, 24 pos.

# Electronic housing - UEGH 45/2-SMD - 2757173

Dimensioned drawing

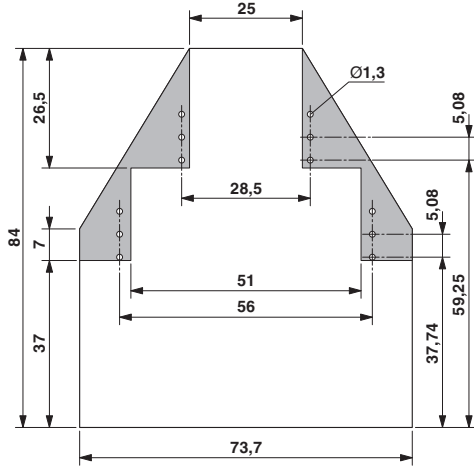

Schematic diagram

