



Chipsmall Limited consists of a professional team with an average of over 10 year of expertise in the distribution of electronic components. Based in Hongkong, we have already established firm and mutual-benefit business relationships with customers from,Europe,America and south Asia,supplying obsolete and hard-to-find components to meet their specific needs.

With the principle of "Quality Parts,Customers Priority,Honest Operation,and Considerate Service",our business mainly focus on the distribution of electronic components. Line cards we deal with include Microchip,ALPS,ROHM,Xilinx,Pulse,ON,Everlight and Freescale. Main products comprise IC,Modules,Potentiometer,IC Socket,Relay,Connector.Our parts cover such applications as commercial,industrial, and automotives areas.

We are looking forward to setting up business relationship with you and hope to provide you with the best service and solution. Let us make a better world for our industry!



Contact us

Tel: +86-755-8981 8866 Fax: +86-755-8427 6832

Email & Skype: info@chipsmall.com Web: www.chipsmall.com

Address: A1208, Overseas Decoration Building, #122 Zhenhua RD., Futian, Shenzhen, China



EFG 45-LG/BS GY

Order No.: 2757474

<http://eshop.phoenixcontact.de/phoenix/treeViewClick.do?UID=2757474>Electronic module, for insertion of two printed circuit boards, without
screw connection terminal blocks

Commercial data	
GTIN (EAN)	 4 017918 063566
sales group	F092
Pack	5 pcs.
Customs tariff	85472000
Catalog page information	Page 550 (CC-2009)

Product notes

WEEE/RoHS-compliant since:
05/20/2005

<http://www.download.phoenixcontact.com>
Please note that the data given here has been taken from the online catalog. For comprehensive information and data, please refer to the user documentation. The General Terms and Conditions of Use apply to Internet downloads.

Technical data

General	
Housing type	Complete housing
Housing material	polycarbonate
Color	gray

Dimensions / positions

Length	118 mm
Width	45 mm

Technical data

Ambient temperature (operation)	-40 °C ... 125 °C
Inflammability class acc. to UL 94	V0
Power dissipation at 20°C in the horizontal mounting position	9.5 W 11.5 W

Accessories

Item	Designation	Description
------	-------------	-------------

General

1700008	FRONT 2,5-H/SA 5	PC terminal block, Nominal current: 24 A, Nom. voltage: 250 V, Pitch: 5 mm, Number of positions: 1, Type of connection: Screw connection, Mounting: Soldering, Conductor/PCB connection direction: 0 °, Color: green, The article can be aligned to create different nos. of positions!
---------	------------------	---

Diagrams/Drawings

Dimensioned drawing

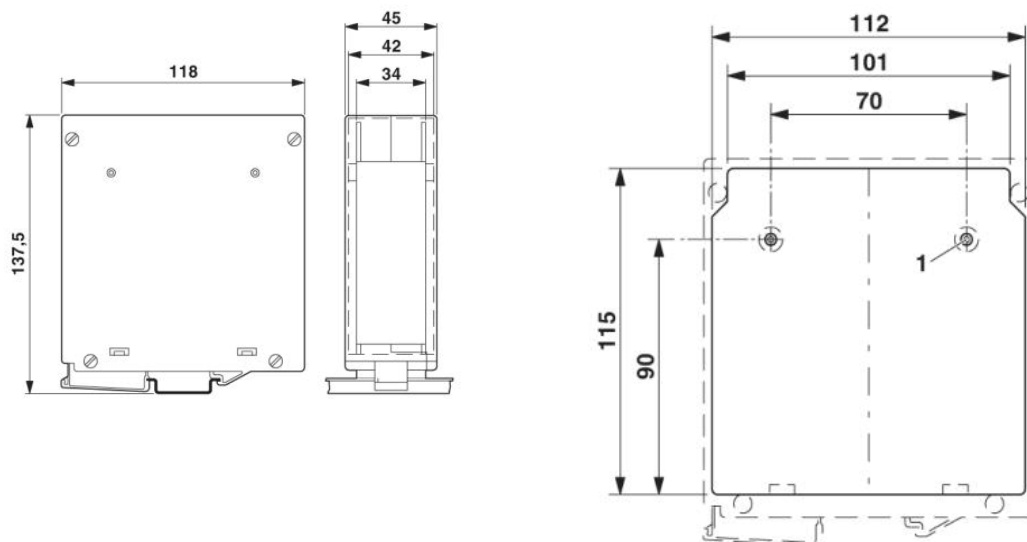

1 = Diameter 3.2 mm for M3

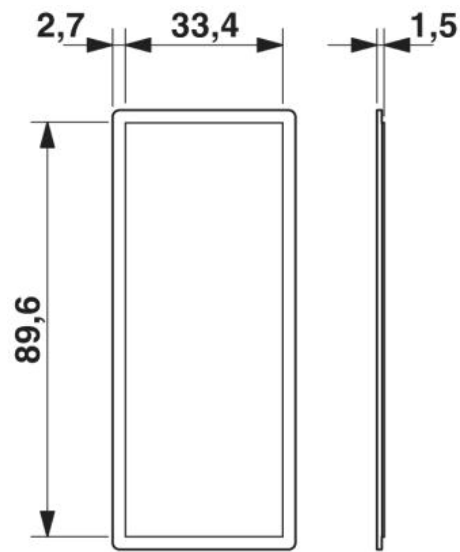

Side element (front and back)

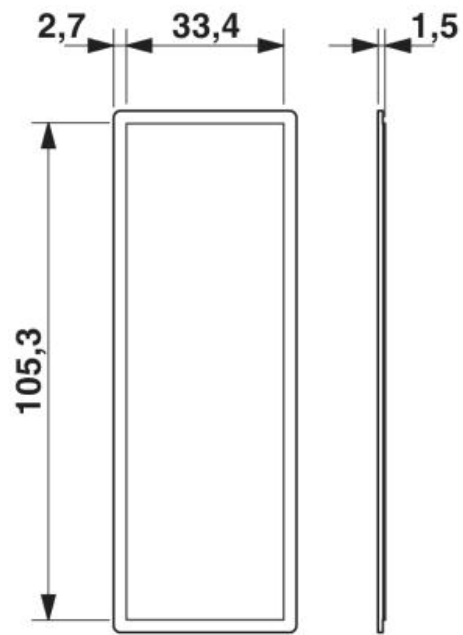

Cover element

Address

PHOENIX CONTACT Deutschland GmbH
Flachmarktstr. 8
32825 Blomberg, Germany
Phone +49 5235 3 12000
Fax +49 5235 3 41200
<http://www.phoenixcontact.de>



© 2010 Phoenix Contact
Technical modifications reserved;