



Chipsmall Limited consists of a professional team with an average of over 10 year of expertise in the distribution of electronic components. Based in Hongkong, we have already established firm and mutual-benefit business relationships with customers from,Europe,America and south Asia,supplying obsolete and hard-to-find components to meet their specific needs.

With the principle of “Quality Parts,Customers Priority,Honest Operation,and Considerate Service”,our business mainly focus on the distribution of electronic components. Line cards we deal with include Microchip,ALPS,ROHM,Xilinx,Pulse,ON,Everlight and Freescale. Main products comprise IC,Modules,Potentiometer,IC Socket,Relay,Connector.Our parts cover such applications as commercial,industrial, and automotives areas.

We are looking forward to setting up business relationship with you and hope to provide you with the best service and solution. Let us make a better world for our industry!



Contact us

Tel: +86-755-8981 8866 Fax: +86-755-8427 6832

Email & Skype: info@chipsmall.com Web: www.chipsmall.com

Address: A1208, Overseas Decoration Building, #122 Zhenhua RD., Futian, Shenzhen, China



SUBCON 9/F-SH

Order No.: 2761499

The illustration shows version SUBCON 9/M-SH

<http://eshop.phoenixcontact.de/phoenix/treeViewClick.do?UID=2761499>

SUB-D connector with one cable entry, 9-pos., female version



RS-232 RS-422

Commercial data

EAN	4017918064730
Pack	1 pcs.
Customs tariff	85366990
Weight/Piece	0.0495 KG
Catalog page information	Page 555 (IF-2009)

Product notes

WEEE/RoHS-compliant since:
10/17/2006

<http://www.download.phoenixcontact.com>
Please note that the data given here has been taken from the online catalog. For comprehensive information and data, please refer to the user documentation. The General Terms and Conditions of Use apply to Internet downloads.

Technical data

General data

Nominal voltage U_N	60 V AC/DC
Nominal current I_N	1 A
Insertion/withdrawal cycles	> 200
Max. cable diameter	10 mm

Min. cable diameter	4 mm
SUBCON fixing screws	4-40 UNC
Tightening torque	0.4 Nm
Ambient temperature (operation)	-20 °C ... 75 °C
Housing material	ABS, metal-plated
Pin assignment	All connections are 1:1 on the screw terminal block
Width	16 mm
Height	44.5 mm
Length	56.4 mm

Connection data

Connection	D-SUB connection
Number of positions	9
Type of connection	D-SUB socket
Connection	PCB connection
Type of connection	Screw connection
Conductor cross section solid min.	0.14 mm ²
Conductor cross section solid max.	1.5 mm ²
Conductor cross section stranded min.	0.14 mm ²
Conductor cross section stranded max.	1 mm ²
Conductor cross section AWG/kcmil min.	26
Conductor cross section AWG/kcmil max	16
Stripping length	5 mm
Tightening torque	0.4 Nm

Certificates / Approvals



Certification CUL, GOST, UL

Accessories

Item	Designation	Description
Assembly		
2799694	SUBCON-SHORT-SCREW	Optional fixing screw, short (w/o knurl)

Literature

2743792	IBS SYS PRO INST UM	User Manual, German, for project planning and installation of the INTERBUS system, with collection of data sheets
2743802	IBS SYS PRO INST UM E	User Manual, English, for project planning and installation of the INTERBUS system, with collection of data sheets

Tools

1772793	CRIMPFOX-1,6-ER-1,50-GH	Crimping tool, for IBS DSUB.../C
---------	-------------------------	----------------------------------

Diagrams/Drawings

Dimensioned drawing

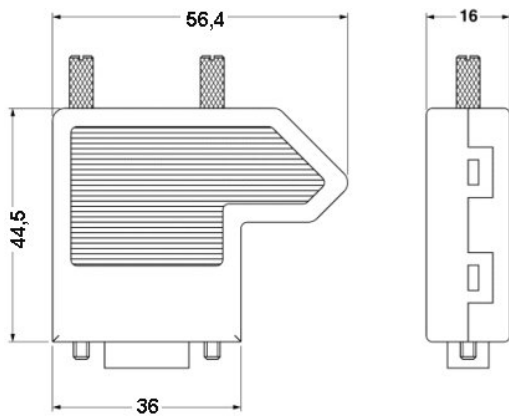

Address

PHOENIX CONTACT Deutschland GmbH
Flachmarktstr. 8
32825 Blomberg, Germany
Phone +49 5235 3 12000
Fax +49 5235 3 41200
<http://www.phoenixcontact.de>



© 2010 Phoenix Contact
Technical modifications reserved;