



Chipsmall Limited consists of a professional team with an average of over 10 year of expertise in the distribution of electronic components. Based in Hongkong, we have already established firm and mutual-benefit business relationships with customers from,Europe,America and south Asia,supplying obsolete and hard-to-find components to meet their specific needs.

With the principle of “Quality Parts,Customers Priority,Honest Operation,and Considerate Service”,our business mainly focus on the distribution of electronic components. Line cards we deal with include Microchip,ALPS,ROHM,Xilinx,Pulse,ON,Everlight and Freescale. Main products comprise IC,Modules,Potentiometer,IC Socket,Relay,Connector.Our parts cover such applications as commercial,industrial, and automotives areas.

We are looking forward to setting up business relationship with you and hope to provide you with the best service and solution. Let us make a better world for our industry!



Contact us

Tel: +86-755-8981 8866 Fax: +86-755-8427 6832

Email & Skype: info@chipsmall.com Web: www.chipsmall.com

Address: A1208, Overseas Decoration Building, #122 Zhenhua RD., Futian, Shenzhen, China



Electronic housing - EG 45-A/PC GN - 2764878

Please be informed that the data shown in this PDF Document is generated from our Online Catalog. Please find the complete data in the user's documentation. Our General Terms of Use for Downloads are valid (<http://phoenixcontact.com/download>)

Housing cover, for connection on both sides



The figure shows a fully mounted version of the electronic housing

Why buy this product

- ✓ Tool-free mounting
- ✓ Date of manufacture and material and part identification embossed on the housing (recyclability)
- ✓ Fast snap-on mounting on symmetrical DIN rails according to EN 60715
- ✓ Practical and easy-to-wire conductor connection using extra finely stranded sturdy screw terminal blocks up to 2.5 mm²
- ✓ Optimum accommodation of electronic components with graded pitches with a design width of 22.5 mm, 45 mm, 67.5 mm, and 90 mm
- ✓ Functional and industry-oriented housing technology
- ✓ Shock and contamination-proof accommodation of electronic components (IP40 housing, IP20 terminal blocks)

Key Commercial Data

Packing unit	10 STK
GTIN	
GTIN	4017918119676

Technical data

General

Housing type	Component housing
Color (RAL)	green

Ambient conditions

Ambient temperature (operation)	80 °C
---------------------------------	-------

Dimensions

Length	75 mm
Constructional height	17.5 mm

Electronic housing - EG 45-A/PC GN - 2764878

Technical data

Dimensions

Width	45 mm
Depth	75 mm

Technical data

Number of positions	16
---------------------	----

Environmental Product Compliance

China RoHS	Environmentally friendly use period: unlimited = EFUP-e
	No hazardous substances above threshold values

Drawings

Dimensional drawing

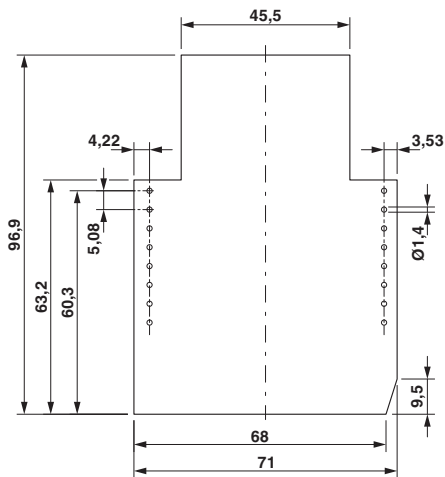

Dimensional drawing

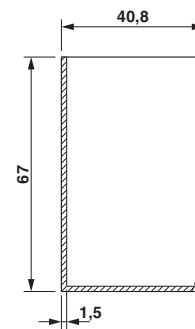

valid for PCB 1; 3; 5 and 6, see explosion drawing

Component mounting side, if the double-level upper part is used

Dimensional drawing

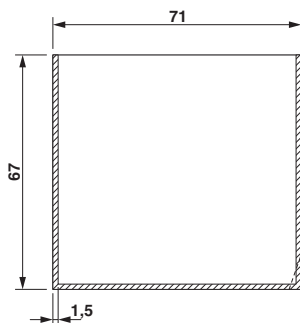

valid for PCB 7 and 12, see explosion drawing

Dimensional drawing

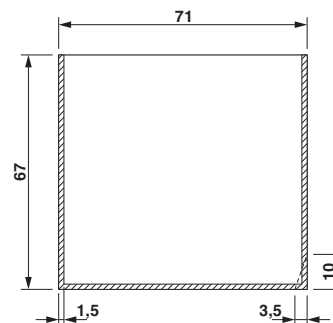

valid for PCB 10, see explosion drawing

Electronic housing - EG 45-A/PC GN - 2764878

Dimensional drawing

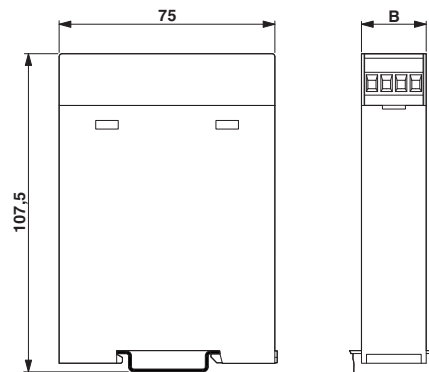

Approvals

Approvals

Approvals

UL Recognized

Ex Approvals

Approval details

UL Recognized



<http://database.ul.com/cgi-bin/XYV/template/LISEXT/1FRAME/index.htm>

FILE E 240868

Phoenix Contact 2018 © - all rights reserved
<http://www.phoenixcontact.com>

PHOENIX CONTACT GmbH & Co. KG
Flachsmarktstr. 8
32825 Blomberg
Germany
Tel. +49 5235 300
Fax +49 5235 3 41200
<http://www.phoenixcontact.com>