



Chipsmall Limited consists of a professional team with an average of over 10 year of expertise in the distribution of electronic components. Based in Hongkong, we have already established firm and mutual-benefit business relationships with customers from,Europe,America and south Asia,supplying obsolete and hard-to-find components to meet their specific needs.

With the principle of "Quality Parts,Customers Priority,Honest Operation,and Considerate Service",our business mainly focus on the distribution of electronic components. Line cards we deal with include Microchip,ALPS,ROHM,Xilinx,Pulse,ON,Everlight and Freescale. Main products comprise IC,Modules,Potentiometer,IC Socket,Relay,Connector.Our parts cover such applications as commercial,industrial, and automotives areas.

We are looking forward to setting up business relationship with you and hope to provide you with the best service and solution. Let us make a better world for our industry!



## Contact us

Tel: +86-755-8981 8866 Fax: +86-755-8427 6832

Email & Skype: info@chipsmall.com Web: www.chipsmall.com

Address: A1208, Overseas Decoration Building, #122 Zhenhua RD., Futian, Shenzhen, China



## Electronic housing - EG 90-A/PC GN - 2764988

Please be informed that the data shown in this PDF Document is generated from our Online Catalog. Please find the complete data in the user's documentation. Our General Terms of Use for Downloads are valid (<http://phoenixcontact.com/download>)



Housing cover, for connection on both sides

Illustration shows a fully mounted version of the electronic housing

### Product Features

- ✓ Tool-free mounting
- ✓ Functional and industry-oriented housing technology
- ✓ Date of manufacture and material and part identification embossed on the housing (recyclability)
- ✓ Optimum accommodation of electronic components with graded pitches with a design width of 22.5 mm, 45 mm, 67.5 mm, and 90 mm
- ✓ Practical and easy-to-wire conductor connection using extra finely stranded sturdy screw terminal blocks up to 2.5 mm<sup>2</sup>
- ✓ Fast snap-on mounting on symmetrical DIN rails according to EN 60715
- ✓ Shock and contamination-proof accommodation of electronic components (IP40 housing, IP20 terminal blocks)



### Key commercial data

Packing unit	1 pc
GTIN	 4 017918 107932
Weight per Piece (excluding packing)	25.64 GRM
Custom tariff number	85369010
Country of origin	Germany

### Technical data

#### General

Housing type	Component housing
Housing material	ABS
Color	green

## Electronic housing - EG 90-A/PC GN - 2764988

### Technical data

#### Ambient conditions

Ambient temperature (operation)	80 °C
---------------------------------	-------

#### Dimensions

Length	75 mm
Constructional height	17.5 mm
Width	90 mm

#### Technical data

Inflammability class according to UL 94	V0
Number of positions	34

### Classifications

#### eCl@ss

eCl@ss 4.0	27180401
eCl@ss 4.1	27180401
eCl@ss 5.0	27180506
eCl@ss 5.1	27180506
eCl@ss 6.0	27180802
eCl@ss 7.0	27182702
eCl@ss 8.0	27182702

#### ETIM

ETIM 2.0	EC001031
ETIM 3.0	EC001031
ETIM 4.0	EC001031
ETIM 5.0	EC000886

#### UNSPSC

UNSPSC 6.01	31261501
UNSPSC 7.0901	31261501
UNSPSC 11	31261501
UNSPSC 12.01	31261501
UNSPSC 13.2	31261501

### Approvals

#### Approvals

---

# Electronic housing - EG 90-A/PC GN - 2764988

## Approvals

Approvals

UL Recognized

---

Ex Approvals

---

Approvals submitted

---

## Approval details



## Drawings

Dimensioned drawing

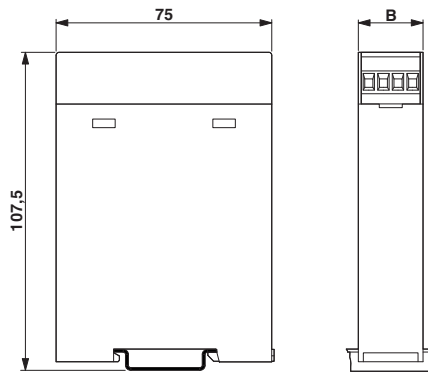

# Electronic housing - EG 90-A/PC GN - 2764988

Explosion drawing

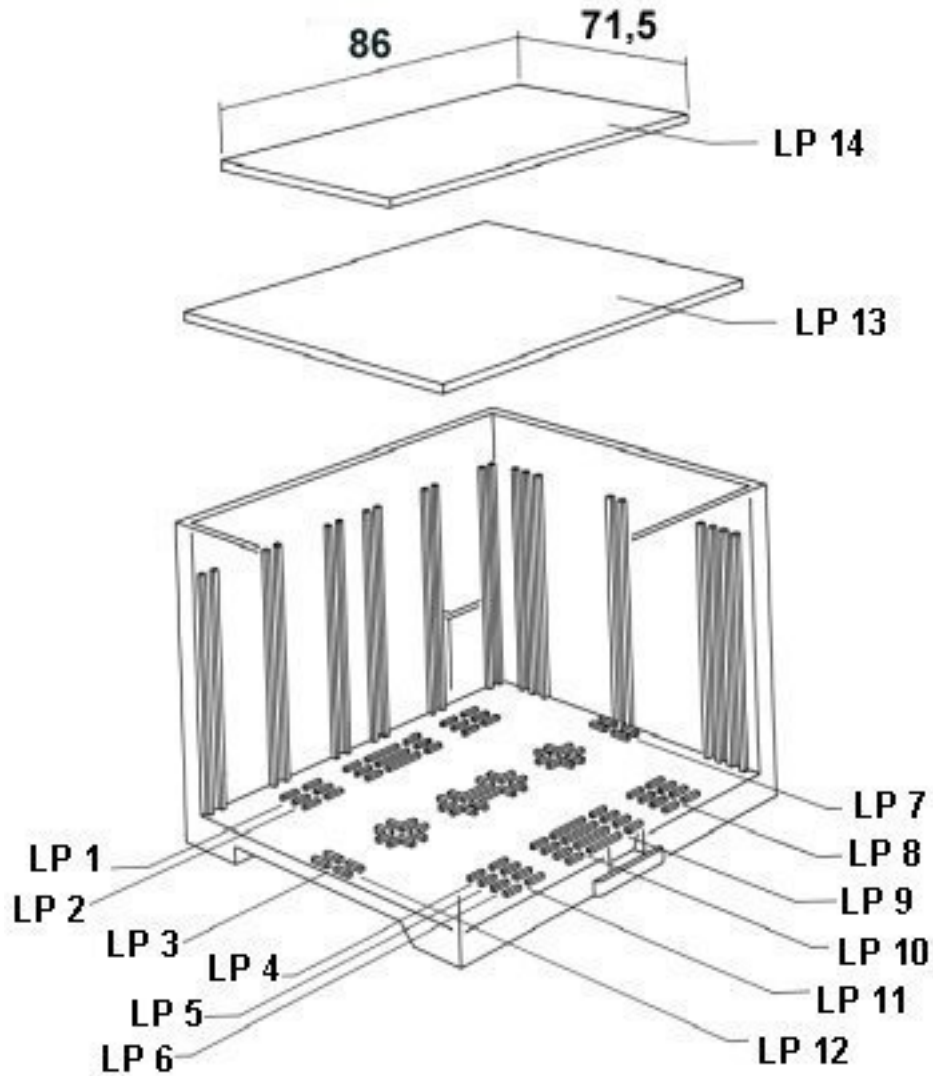

valid for PCB 13

# Electronic housing - EG 90-A/PC GN - 2764988

Explosion drawing

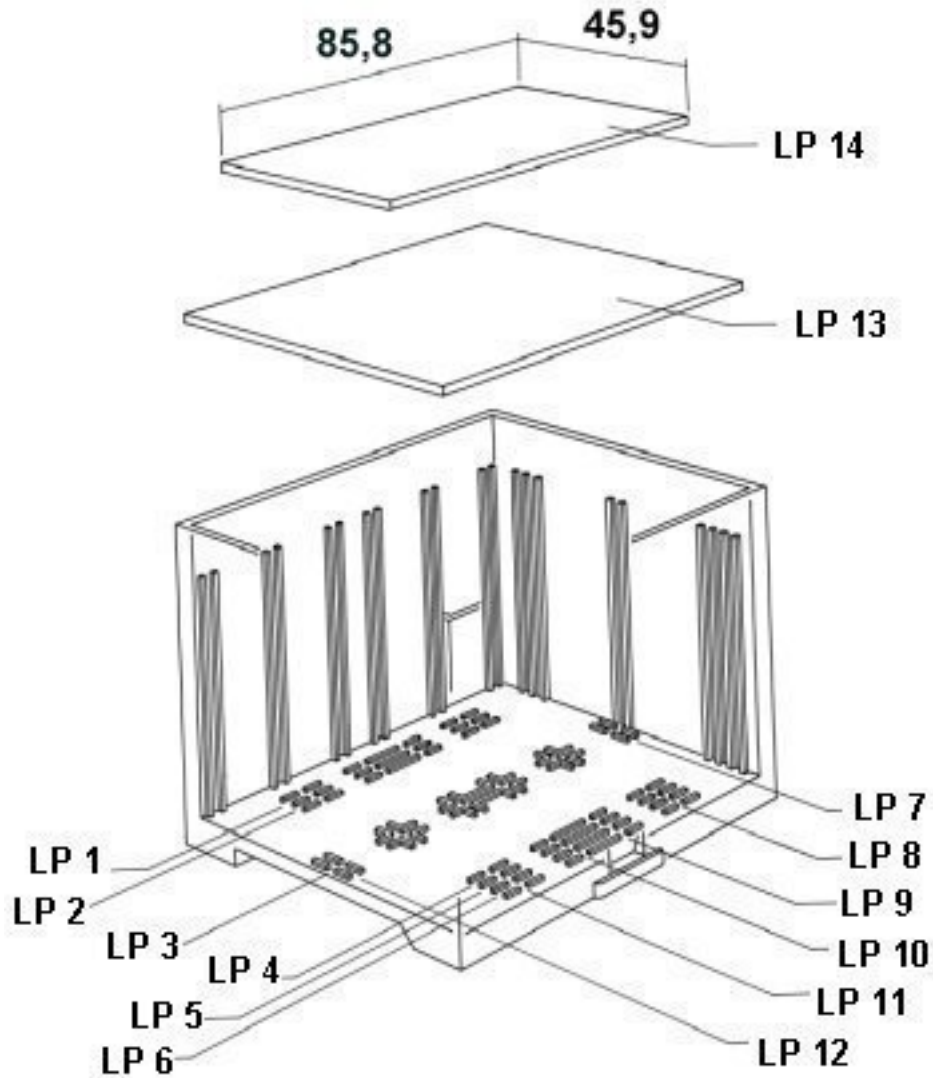

valid for PCB 14

# Electronic housing - EG 90-A/PC GN - 2764988

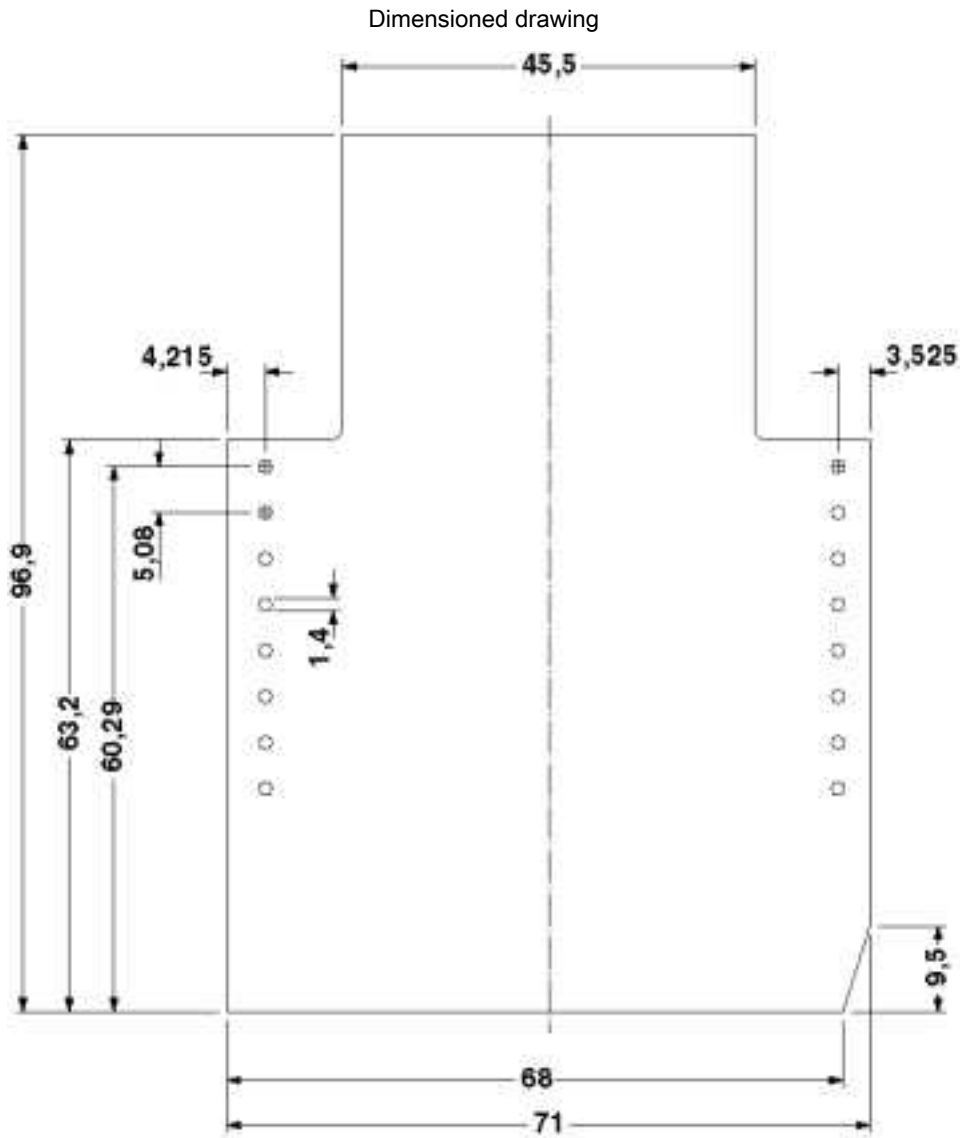

Component mounting side, if the double-level upper part is used

# Electronic housing - EG 90-A/PC GN - 2764988

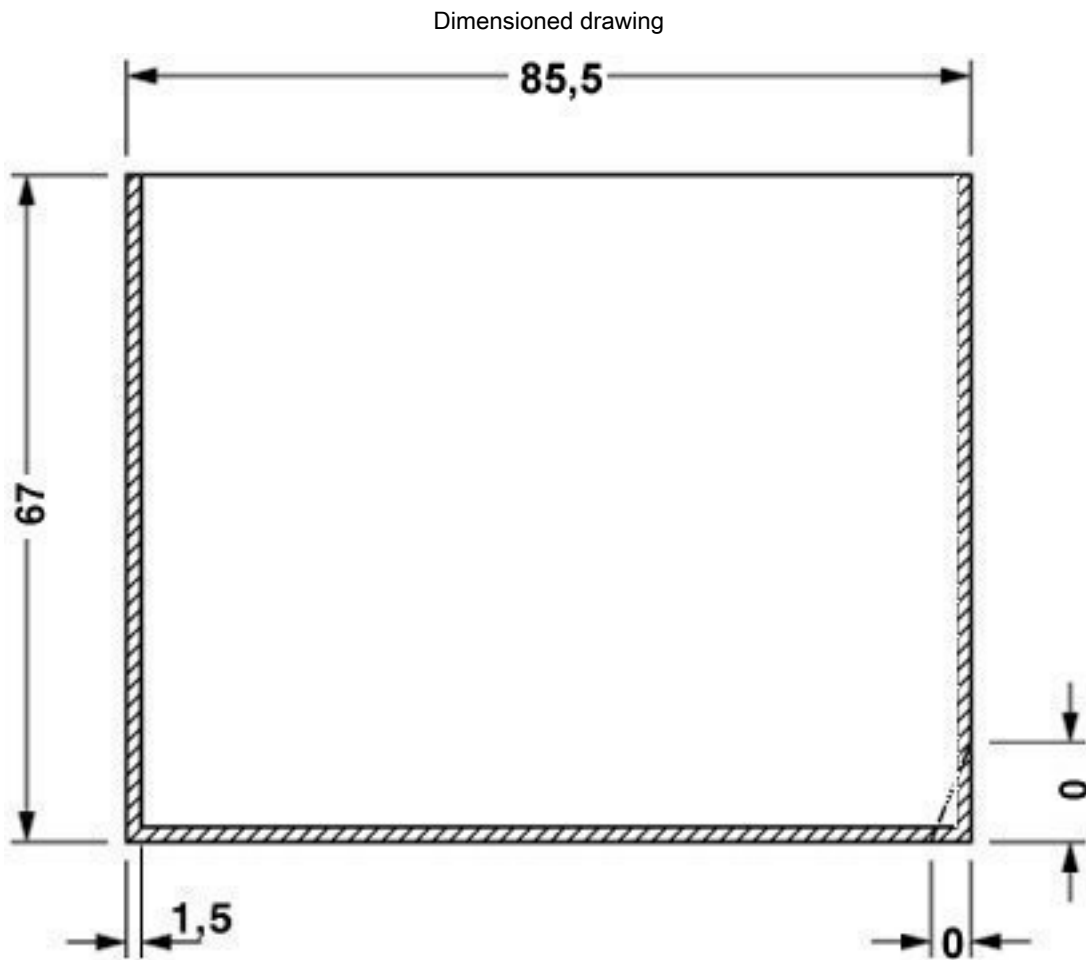

valid for PCB 1; 2; 3; 4; 5 und 6, see explosion drawing



# Electronic housing - EG 90-A/PC GN - 2764988

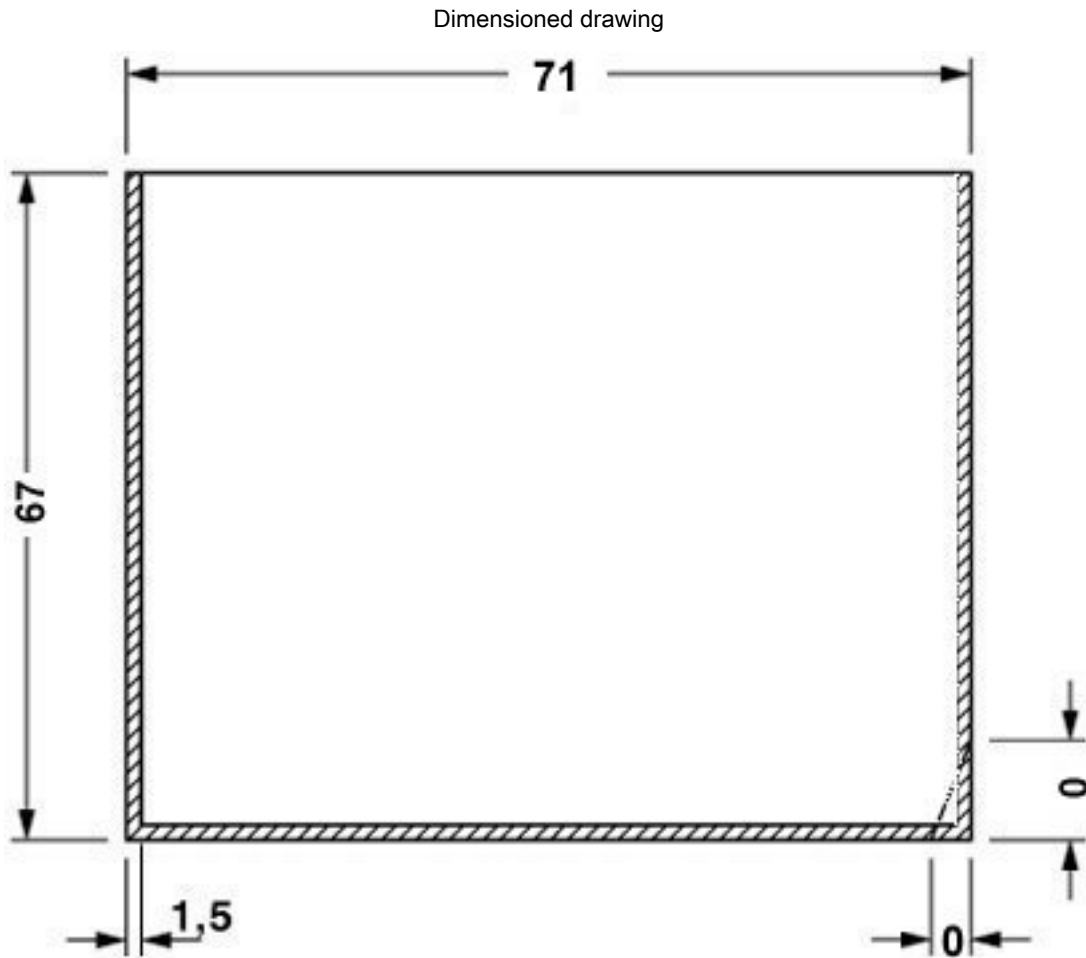

valid for PCB 7; 8; 11 and 12, see explosion drawing

## Electronic housing - EG 90-A/PC GN - 2764988

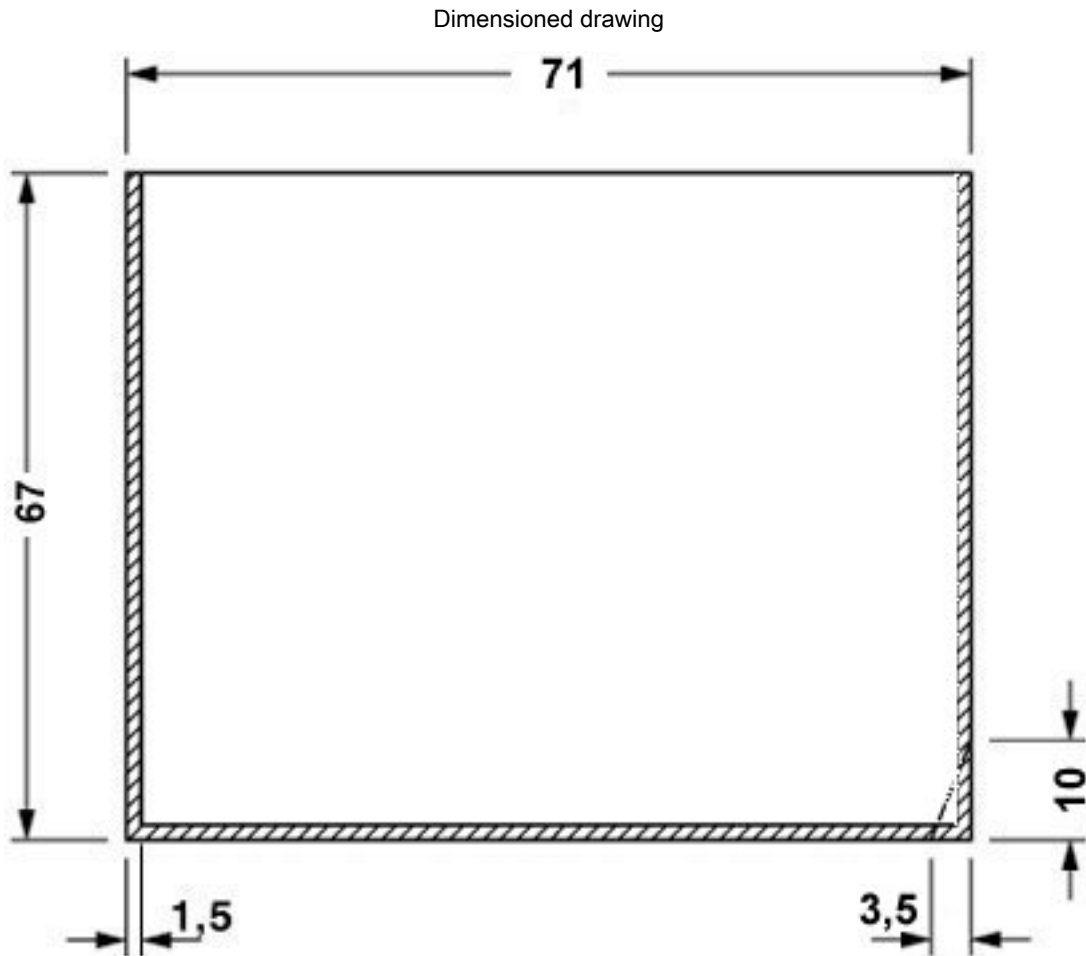

valid for PCB 9 and 10, see explosion drawing