



Chipsmall Limited consists of a professional team with an average of over 10 year of expertise in the distribution of electronic components. Based in Hongkong, we have already established firm and mutual-benefit business relationships with customers from,Europe,America and south Asia,supplying obsolete and hard-to-find components to meet their specific needs.

With the principle of “Quality Parts,Customers Priority,Honest Operation,and Considerate Service”,our business mainly focus on the distribution of electronic components. Line cards we deal with include Microchip,ALPS,ROHM,Xilinx,Pulse,ON,Everlight and Freescale. Main products comprise IC,Modules,Potentiometer,IC Socket,Relay,Connector.Our parts cover such applications as commercial,industrial, and automotives areas.

We are looking forward to setting up business relationship with you and hope to provide you with the best service and solution. Let us make a better world for our industry!



Contact us

Tel: +86-755-8981 8866 Fax: +86-755-8427 6832

Email & Skype: info@chipsmall.com Web: www.chipsmall.com

Address: A1208, Overseas Decoration Building, #122 Zhenhua RD., Futian, Shenzhen, China



FLM DI 8 M8

Fieldline modular M8 device with 8 digital inputs

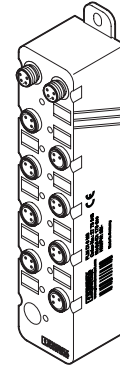

AUTOMATION

Data sheet
7518_en_02

© PHOENIX CONTACT 2010-06-15

1 Description

The device is designed for use on the Fieldline Modular M8 local bus, which is opened by a Fieldline or Inline bus coupler. It is used to acquire digital signals.

Features

- Connection to the Fieldline Modular local bus using M8 connectors
- Connection of digital sensors using M8 connectors
- Flexible power supply concept
- Diagnostic and status indicators
- Short-circuit and overload protection of the sensor supply
- IP65/67 protection



Make sure you always use the latest documentation.
This can be downloaded at www.phoenixcontact.net/catalog.



This data sheet is only valid in association with the FLS FLM SYS INST UM E user manual and the user manual for your bus system (see "Ordering data" on page 2).

2 Ordering data

Product

Description	Type	Order No.	Pcs./Pkt.
Fieldline Modular M8 device with eight digital inputs Housing color: anthracite, RAL 7016	FLM DI 8 M8	2773348	1

Accessories

Description	Type	Order No.	Pcs./Pkt.
Protective caps (for unused female connectors)	PROT-M8	1682540	5
M8 connector with screw connection, shielded, male, 4-pos.	SACC-M8MS-4CON-M-0,34-SH	1542897	1
M8 connector with screw connection, shielded, female, 4-pos.	SACC-M8FS-4CON-M-0,34-SH	1542910	1
Marking labels	ZBF 8:UNBEDRUCKT	0808781	10
Torque screwdriver with preset torque of 0.2 Nm and 4 mm hexagonal drive	TSD 02 SAC	1208487	1
Nut for assembling preassembled SAC M8 cables and protective caps (PROT-M8) for 4 mm hexagonal screwdriver	SAC BIT M8-D10	1208461	1
Nut for assembling SACC M8 connectors, for 4 mm hexagonal screwdriver	SACC BIT M8-D12	1208474	1



Additional accessories for connecting the sensors can be found in the Phoenix Contact PLUSCON catalog.

Documentation

Description	Type
"Installation of devices in the Fieldline product range" user manual	FLS FLM SYS INST UM E
"Configuring an INTERBUS system using devices in the Fieldline product range" user manual	FLS FLM IB SYS PRO UM E
"Configuring a PROFIBUS-DP system using devices in the Fieldline product range" user manual	FLS FLM PB SYS PRO UM E
"Configuring a DeviceNet™ system using devices in the Fieldline product range" user manual	FLS FLM DN SYS PRO UM E
"Configuring a CANopen® system using devices in the Fieldline product range" user manual	FLS FLM CO SYS PRO UM E
"Configuring an Ethernet system using devices in the Fieldline product range" user manual	FLS FLM ETH SYS PRO UM E
"Configuring an Ethernet/IP system using devices in the Fieldline product range" user manual	FLM EIP SYS PRO UM E

3 Technical data

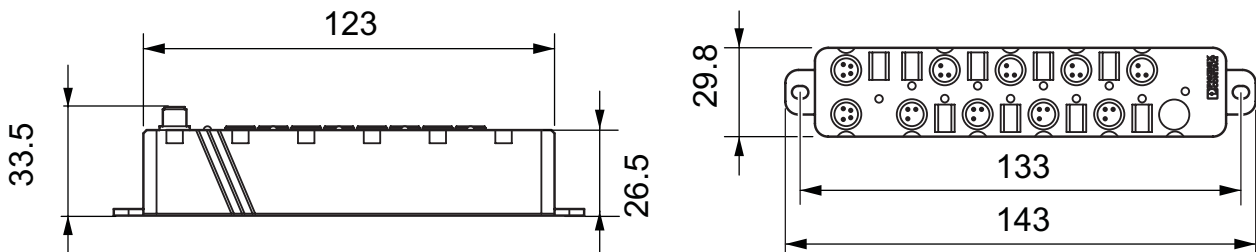

7216A002

Figure 1 Device dimensions in mm

General data

Order designation	FLM DI 8 M8
Order No.	2773348
Dimensions (width x height (incl. fixing clips) x depth)	29.8 mm x 143 mm x 33.5 mm
Weight	137 g
Operating mode	Process data mode with 8 bits
Transmission speed	500 kbaud
Connection method for sensors	2 and 3-wire technology
Permissible temperature (operation)	-25°C to +60°C
Permissible temperature (storage/transport)	-25°C to +85°C
Humidity (operation)	5% to 95%
Permissible humidity (storage/transport)	10% to 95%
Permissible air pressure (operation)	80 kPa to 106 kPa (up to 2000 m above sea level)
Permissible air pressure (storage/transport)	70 kPa to 106 kPa (up to 3000 m above sea level)
Degree of protection	IP65/IP67 according to IEC 60529
Protection class	Class 3 in acc. with VDE 0106, IEC 60536

Mechanical requirements

Vibration test, sinusoidal vibrations according to EN 60068-2-6	5g load in each direction
Shock test according to EN 60068-2-27	30g load, half sinusoidal wave positive and negative in each direction



For additional information on mechanical requirements and ambient conditions, please contact Phoenix Contact.

Power supply

Nominal value	24 V DC
Tolerance	± 25% including 5% ripple
Current consumption at U_{LS} at 24 V DC	30 mA, typical (40 mA, maximum) + sensor current (600 mA, maximum)

Digital inputs

Number	8
Input design	According to IEC 61131-2 Type 1
Definition of switching thresholds	
Maximum low-level voltage	$U_{Lmax} < 5 \text{ V}$
Minimum high-level voltage	$U_{Hmin} > 11 \text{ V}$
Nominal input voltage	24 V DC
Area	$-30 \text{ V DC} < U_{IN} < +30 \text{ V DC}$
Nominal input current	5 mA
Current flow	Linear in the range $2 \text{ V} < U_{IN} < 30 \text{ V}$
Delay time	$t_{ON} < 1 \text{ ms}$, typical $t_{OFF} < 1 \text{ ms}$, typical
Permissible cable length to the sensor	< 30 m

Input characteristic curve

Input voltage (V)	Typical input current (mA)
$-30 < U_{IN} < 0.7$	0
3	0.5
6	1.0
9	1.6
12	2.3
15	3.0
18	3.8
21	4.5
24	5.2
27	6.0
30	6.7

Sensor supply

Minimum sensor voltage	$U_S - 1 \text{ V}$
Nominal current per channel	600 mA
Nominal current per device	600 mA
Overload protection	Electronic per device
Short circuit protection	Electronic per device

Error messages to the higher-level control or computer system

Sensor supply short circuit	Yes
Sensor supply overload	Yes



If an error is triggered by an overload or short circuit of the sensor supply, the device disconnects the sensor supply to all channels and sends an I/O error message to the master.

Interface

Bus system	Fieldline modular M8 local bus
Incoming bus	
Coupling of shield connection	Directly to FE
Transmission speed	500 kbaud
Outgoing bus	
Coupling of shield connection	Directly to FE
Transmission speed	500 kbaud

Electrical isolation/isolation of the voltage areas

For device connection, please note the instructions and regulations in the "Installation of devices in the Fieldline product range" user manual, FLS FLM SYS INST UM E.

Separate potentials in the FLM DI 8 M8

Test distance	Test voltage
FE / 24 V supply (sensor supply and communications power and inputs)	500 V AC, 50 Hz, 1 min.
FE / logic (logic / incoming bus / outgoing bus)	500 V AC, 50 Hz, 1 min.
24 V supply (sensor supply and communications power and inputs) / logic (logic / incoming bus / outgoing bus)	500 V AC, 50 Hz, 1 min.

Approvals

For the latest approvals, please visit www.phoenixcontact.net/catalog.

4 Connector assignment

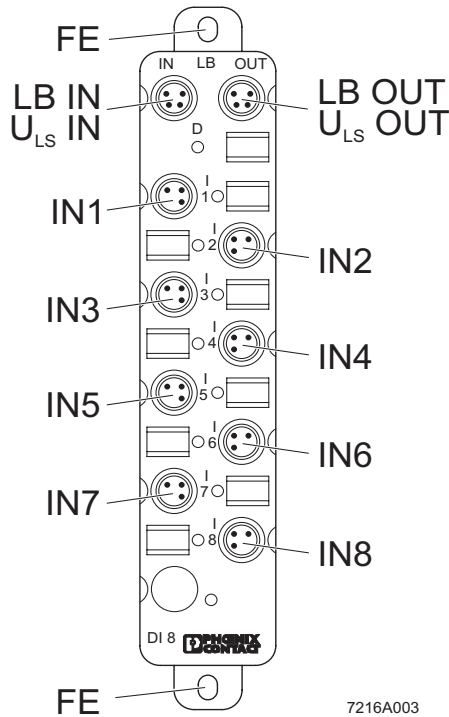

7216A003

Figure 2 FLM DI 8 M8 device connections

4.1 Pin assignment of LB IN/LB OUT

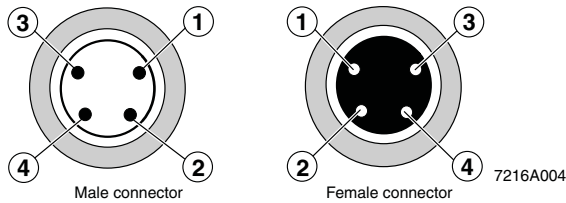

7216A004

Figure 3 Pin assignment of LB IN/LB OUT

Designation	Meaning
FE	Functional earth ground
LB IN	Local bus IN
LB OUT	Local bus OUT
U _{LS} IN	Power supply IN (logic and sensors)
U _{LS} OUT	Power supply OUT (logic and sensors) for additional devices
IN1 to IN8	Inputs 1 to 8



NOTE:

In general, the maximum current load of 3 A per contact must not be exceeded.

Pin	IN	OUT
1	Supply voltage U _{LS} (device and sensors)	Supply voltage U _{LS} (device and sensors)
2	DI	DO
3	GND U _{LS}	GND U _{LS}
4	$\overline{\text{DI}}$	$\overline{\text{DO}}$



The thread is used for shielding.

4.2 Pin assignment of the inputs

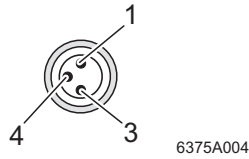

Figure 4 Pin assignment of the inputs

Pin	Female input connector
1	24 V U _S supply voltage for sensors
3	GND U _{LS}
4	Input

5 Local diagnostic and status indicators

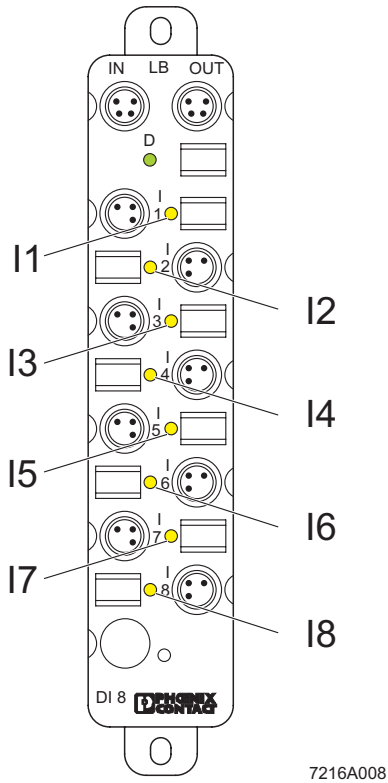

Figure 5 Local diagnostic and status indicators on the FLM DI 8 M8

Des.	Color	Meaning
D	Green LED	Diagnostics
	ON:	Bus active
	Flashing, 0.5 Hz:	Communications power present, bus not active
	Flashing, 2 Hz:	Communications power present, peripheral fault, sensor supply overload
	Flashing, 4 Hz:	Communications power present, transmission path before the flashing device failed, device before the flashing device failed, devices after the flashing device are not part of the configuration frame.
	OFF:	Communications power not present, bus not active
I1 to I8	Yellow LED	Status indicators for the inputs
	ON:	Input active
	OFF:	Input inactive

6 Internal basic circuit diagram

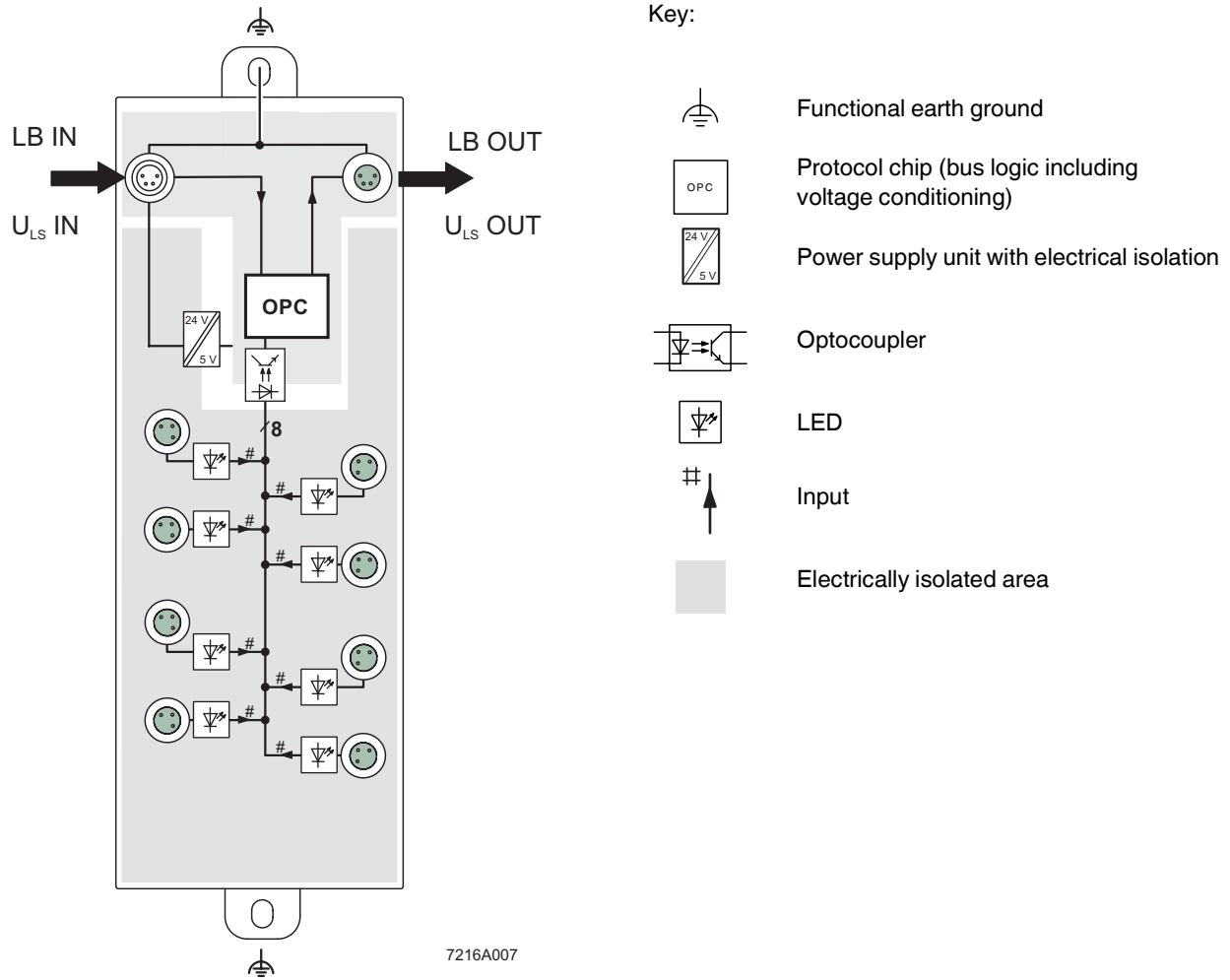

Figure 6 Internal wiring of the connections



For information on electrically isolated areas, please refer to page 4.

7 Connection example

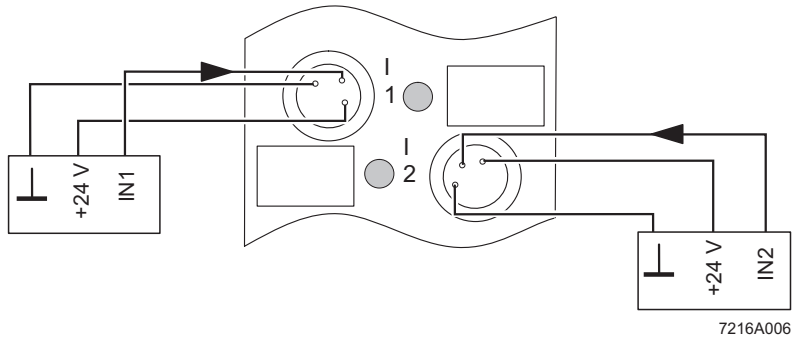

Figure 7 Typical sensor connections

Connection notes



NOTE: Meet noise immunity requirements

Connect FE using a mounting screw when mounting on a conductive surface.

When mounting the device on a non-conductive surface, FE is connected using the mounting screw via a cable lug.



NOTE: Ensure degree of protection

To ensure IP65/IP67 protection, cover unused female connectors with protective caps.



NOTE: Avoid damage to the electronics

Make sure you only supply the sensors with the voltage U_S provided at the terminal points.



NOTE: Avoid polarity reversal

Avoid polarity reversal of the supply voltages U_{LS} in order to prevent damage to the device.



NOTE: Observe connection assignment

When connecting the sensors, observe the assignment of the connection points to the IN process data (see "Process data" on page 9).



NOTE:

Secure the device to a level surface or to a profile. Do not use this device to bridge gaps, i.e., to prevent forces to be transmitted via the device.



NOTE:

Tighten the mounting screws on the support plate with a maximum of 2.8 Nm.



NOTE:

Tighten the union nut of the M8 circular connector and the protective caps (PROT-M8) with 0.2 Nm. To do so, use a torque screwdriver with the corresponding nut, see "Ordering data" on page 2.



NOTE:

In addition, insert as much of the filler litz wire as possible in the connector for the local bus cables with braided shield.

8 Programming data/configuration data

8.1 INTERBUS

ID code	B2 _{hex} (178 _{dec})
Length code	81 _{hex}
Process data channel	8 bits
Input address area	8 bits
Parameter channel (PCP)	0 bits
Register length (bus)	8 bits

8.2 Other bus systems



For the programming data of other bus systems, refer to the appropriate electronic device data sheet (GSD, EDS). For additional information, please refer to the user manuals, see "Ordering data" on page 2.

9 Process data

Assignment of the terminal points to the IN process data

(Byte.bit) view	Byte	Byte 0							
	Bit	7	6	5	4	3	2	1	0
Device	Input	8	7	6	5	4	3	2	1



For the assignment of the illustrated (byte.bit) view to your INTERBUS control or computer system, please refer to the DB GB IBS SYS ADDRESS data sheet, Order No. 9000990.