



Chipsmall Limited consists of a professional team with an average of over 10 year of expertise in the distribution of electronic components. Based in Hongkong, we have already established firm and mutual-benefit business relationships with customers from,Europe,America and south Asia,supplying obsolete and hard-to-find components to meet their specific needs.

With the principle of “Quality Parts,Customers Priority,Honest Operation,and Considerate Service”,our business mainly focus on the distribution of electronic components. Line cards we deal with include Microchip,ALPS,ROHM,Xilinx,Pulse,ON,Everlight and Freescale. Main products comprise IC,Modules,Potentiometer,IC Socket,Relay,Connector.Our parts cover such applications as commercial,industrial, and automotives areas.

We are looking forward to setting up business relationship with you and hope to provide you with the best service and solution. Let us make a better world for our industry!



## Contact us

Tel: +86-755-8981 8866 Fax: +86-755-8427 6832

Email & Skype: info@chipsmall.com Web: www.chipsmall.com

Address: A1208, Overseas Decoration Building, #122 Zhenhua RD., Futian, Shenzhen, China



## Electronic housing - P 1-UEGM - 2792109

Please be informed that the data shown in this PDF Document is generated from our Online Catalog. Please find the complete data in the user's documentation. Our General Terms of Use for Downloads are valid (<http://download.phoenixcontact.com>)

PCB, for screw and slip-on connection, for custom fitting electronic components.



### Key commercial data

|                      |  |
|----------------------|--|
| Packing unit         | 1 PCE  |
| GTIN                 | <br>4 017918 072575 |
| Custom tariff number | 85340019   |
| Country of origin    | GERMANY  |

### Technical data

|              |               |
|--------------|---------------|
| Product type | PCB           |
| Approval     | UL Recognized |

### Classifications

#### ETIM

|          |          |
|----------|----------|
| ETIM 2.0 | EC001031 |
| ETIM 3.0 | EC001031 |
| ETIM 4.0 | EC001031 |
| ETIM 5.0 | EC001031 |

#### UNSPSC

|              |          |
|--------------|----------|
| UNSPSC 11    | 31261501 |
| UNSPSC 12.01 | 31261501 |
| UNSPSC 13.2  | 31261501 |

# Electronic housing - P 1-UEGM - 2792109

## Classifications

### UNSPSC

|               |          |
|---------------|----------|
| UNSPSC 6.01   | 31261501 |
| UNSPSC 7.0901 | 31261501 |

### eCl@ss

|            |          |
|------------|----------|
| eCl@ss 4.0 | 27180401 |
| eCl@ss 4.1 | 27180401 |
| eCl@ss 5.0 | 27180506 |
| eCl@ss 5.1 | 27180506 |
| eCl@ss 6.0 | 27180802 |
| eCl@ss 7.0 | 27182702 |

## Approvals

### Approvals

---

Approvals

UL Recognized

---

Ex Approvals

---

Approvals submitted

---

### Approval details

|   |
|---|
| UL Recognized  |
|---|

## Drawings

# Electronic housing - P 1-UEGM - 2792109

Dimensioned drawing

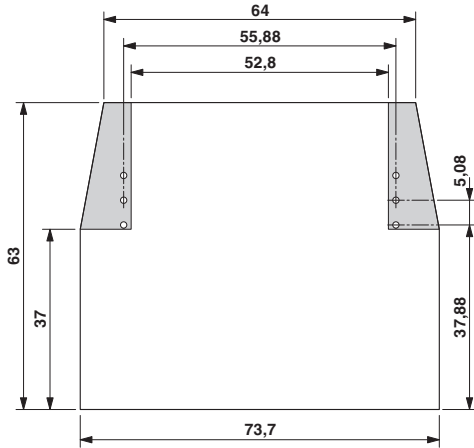

Schematic diagram

