



Chipsmall Limited consists of a professional team with an average of over 10 year of expertise in the distribution of electronic components. Based in Hongkong, we have already established firm and mutual-benefit business relationships with customers from,Europe,America and south Asia,supplying obsolete and hard-to-find components to meet their specific needs.

With the principle of "Quality Parts,Customers Priority,Honest Operation,and Considerate Service",our business mainly focus on the distribution of electronic components. Line cards we deal with include Microchip,ALPS,ROHM,Xilinx,Pulse,ON,Everlight and Freescale. Main products comprise IC,Modules,Potentiometer,IC Socket,Relay,Connector.Our parts cover such applications as commercial,industrial, and automotives areas.

We are looking forward to setting up business relationship with you and hope to provide you with the best service and solution. Let us make a better world for our industry!



Contact us

Tel: +86-755-8981 8866 Fax: +86-755-8427 6832

Email & Skype: info@chipsmall.com Web: www.chipsmall.com

Address: A1208, Overseas Decoration Building, #122 Zhenhua RD., Futian, Shenzhen, China



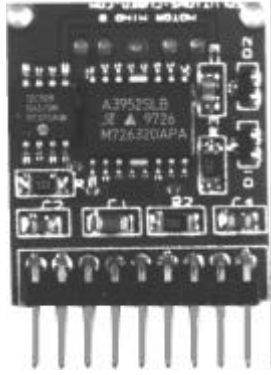

(Shown without heat sink)

Motor Mind B

DC Motor Control Module

*Adjust Speed/Direction

*Easy Serial Interface

*Tachometer/Counter Input



SOLUTIONS CUBED

3029-F Esplanade

Chico, CA 95973

phone (530) 891-8045

fax (530) 891-1643

www.solutions-cubed.com

MINIATURE ENGINEERING MODULES

Motor Mind B

Serial DC Motor Driver Module

FEATURES

- ◆ Controls DC motor direction and speed
- ◆ Up to 30Vdc motors, 3.5A peak
- ◆ Automatic speed control mode
- ◆ Easy to use 1 or 2 wire serial interface
- ◆ Optional tachometer input reads 0-65,535Hz
- ◆ External emergency override input shuts down motor
- ◆ Optional confirmation byte for electrically noisy environments
- ◆ No external components
- ◆ Easy to use SIP package
- ◆ COUNT command for motor positioning systems

DESCRIPTION

Motor Mind Bs sold with silver heat sinks include firmware revision 298 with additional features and enhanced functionality. Motor control is simplified to a serial communication stream. Serial commands can be sent via a one or two wire interface. The short instruction set designed into the Motor Mind B allows the user to implement complex control algorithms quickly and with little effort.

Bi-directional or uni-directional DC motors with operating voltages as great as 30Vdc can be used with the Motor Mind B. This module can handle peak currents as large as 3.5A and continuous currents of 2A. Package power dissipation must not be exceeded during use.

Features include the ability to read a motor's tachometer frequency, automated speed control, 254 discrete steps of speed control, and motor direction changes.

Also included are gate time selections for the tachometer and automated speed control mode, a pulse counting function, and the STATUS command. The Motor Mind B comes complete with a watchdog timer to eliminate the possibility of a system firmware failure.

The Motor Mind B's small size and connection scheme allows the device to be inserted directly into circuit boards for production runs, or into breadboards for easy prototyping.

PIN CONFIGURATION AND MECHANICAL SPECIFICATIONS

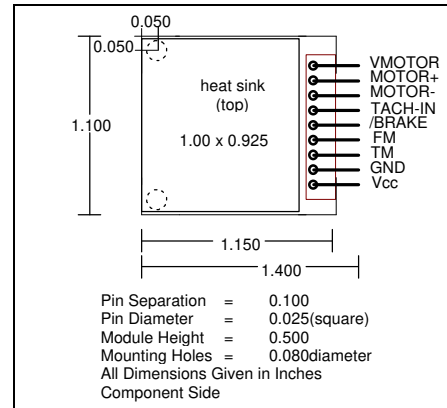

VMOTOR	Voltage supply for motor
MOTOR+	DC motor lead connection
MOTOR-	DC motor lead connection
TACH_IN	Input for encoders and tachometers
/BRAKE	Stops motor when low, does not reset module
FM	Data received <u>from</u> master on this pin
TM	Data sent <u>to</u> master on this pin
GND	Ground potential, all circuit grounds are common
Vcc	Supply input for control circuits

SPECIFICATIONS

ABSOLUTE MAXIMUM RATINGS

note: These are stress ratings only. Stresses above those listed below may cause permanent damage and/or affect device reliability. The operational ratings should be used to determine applicable ranges of operation.

Storage Temperature	-55°C to +150°C
Operating Temperature	-20°C to +85°C
Supply Voltage(Vcc)	0 to 7.0V
Voltage on TM, FM, GND, /BRAKE pins	-0.6V to (Vcc+0.6V)
Voltage on VMOTOR, MOTOR+, MOTOR-, TACH_IN pins	5-30V
Motor Current Load	3.5A peak / 2A continuous

DC ELECTRICAL CHARACTERISTICS

At $T_A = 25^\circ\text{C}$ and $V_{cc} = 5.0\text{V}$ unless otherwise noted.

Characteristic	Symbol	Min	Typ	Max	Unit	Notes
Supply Voltage	Vcc	4.0		7.0	V	
Vcc rise time to ensure good reset	SVdd	0.05			V/ms	If this is not met, the Motor Mind B may start up in an unknown state and may not communicate correctly.
Supply Current	Icc	15	20	40	mA	Current increases as motor speeds increase, highest current occurs when /BRAKE is low.
FM Input Low Voltage	VIL	GND		0.2Vcc	V	
FM Input High Voltage	VIH	2.0 0.2Vcc+1V		Vcc	V	4.0<Vcc<5.0 Full Vcc range User may use better of two specs.
TM Output Low Voltage	VOLTM			0.6	V	
TM Output High Voltage	VIHTM	Vcc			V	TM is open collector
TM Output Pull Up current	ITMPU	2.5	5.0	5.5	mA	TM open collector is tied to Vcc with a 5% 1kΩ resistor.
/BRAKE pin disable motor voltage	VBRK			1.2	V	Low on /BRAKE disables motor, but not communication.
/BRAKE pin current sourced when pulled low	IBRK	2.5	5.0	5.5	mA	/BRAKE is tied to Vcc with a 5% 1kΩ resistor

note: "Typ" values are for design guidance only and are not guaranteed

AC ELECTRICAL CHARACTERISTICSAt $T_A = 25^\circ\text{C}$ and $V_{CC} = 5.0\text{V}$ unless otherwise noted.

Characteristic	Symbol	Min	Typ	Max	Unit	Notes
Communication bit period 2400 baud	TBIT	413	416	419	μS	The bit period is determined by an on-board oscillator, and is temperature sensitive
Offset when a bit is read 2400 baud	TRD	180	200	220	μS	This is used to ensure a bit is valid when read. A bit must be valid for at least this long in order for the communication to not be erroneous
Time for a command from master to be responded to	TTURN	450	500	550	μS	This time is used to allow for a master to change from transmission mode to reception mode
Baud generator error	BGE		2	6	%	
Bit period temperature coefficient	BPTEMPCO	-1.8	-1.6	-1.7	$\text{nS}/^\circ\text{C}$	Therefore at higher temperatures, a <u>slower</u> baud rate may be necessary at the master
PWM duty cycle resolution	TDC	0.39		99.61	%	Speed control is in 254 discrete steps of $\sim 0.39\%$
PWM frequency	TPWM	57	61	65	Hz	64Hz for TACH and SPDCON commands
Saturation voltage of H-bridge's drivers	VCESAT	0.9	1.2	1.8	V	Increased saturation voltage requires higher power dissipation for module
Thermal shutdown temperature	TJ		165		$^\circ\text{C}$	Thermal shutdown has a hysteresis of 15°C
Max peak motor current	IPK		3.5		A	Peak motor current must not exceed spikes of 20 μs duration
Max continuous motor current	ICON		2.0		A	
Max continuous motor current no cooling	IHS	1.2	1.3	1.4	A	Maximum current to load without external cooling devices (fans, etc.)
Tachometer frequency	FTACH	0		65,535	Hz	See frequency section page 5 for limitations
Tachometer read time	TTACH	15.63		2000	ms	Read time based on TACH gate time value
Tachometer input voltage	VTACH	5		30	V	Square wave inputs are ideal, however signals of uneven symmetry will work.

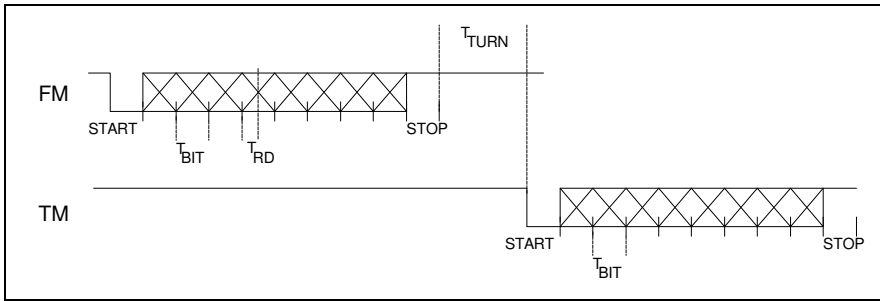

Communication Timing

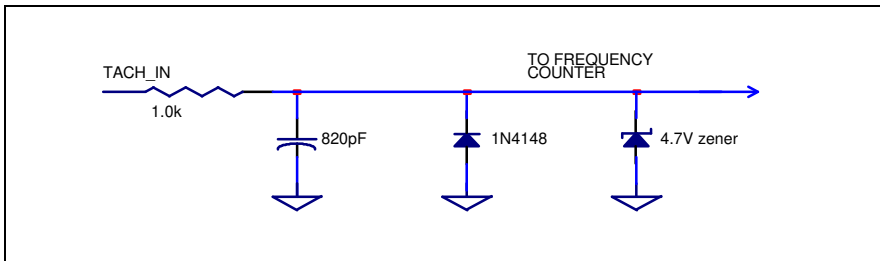

Tachometer Circuit

The TACH_IN circuit is provided for reference. Make sure that your motor's tachometer or encoder is not adversely effected by the circuit above. The tachometer signal level should be between 5-30V. The tachometer circuit reads in values from 0-65,535Hz. Measurement errors are typically +/-5%. Signals such as sine waves and square waves with uneven symmetry will work. The ideal input for this circuit is a logic level square wave with even symmetry, but many signal types will yield accurate frequency measurements. A tachometer signal is necessary in order to use the automated speed control and counting functions (SPDCON, TACH and COUNT).

Firmware revision 298 provides for a tachometer gate time value to be sent with the TACH and SPDCON commands. Omitting the gate time value causes the Motor Mind B to default to a 250ms gate time with a resolution of 8Hz. The Motor Mind B will not default to this 250ms gate time if a gate time value has been included with any previous TACH or SPDCON command. Omitting the gate time value throughout your program makes the Motor Mind B revision 298 firmware backwards compatible with all code written for earlier firmware versions.

Gate Time Value	Gate Time(time spent reading tachometer, T_{TACH})	Duty Cycle Updates per second(SPDCON)	Resolution (TACH)
'80'h	2000ms	1 every 2 seconds	1Hz
'40'h	1000ms	1 every second	2Hz
'20'h	500ms	2 every second	4Hz
'10'h	250ms	4 every second	8Hz
'08'h	125ms	8 every second	16Hz
'04'h	62.5ms	16 every second	32Hz
'02'h	31.25ms	32 every second	64Hz
'01'h	15.625ms	64 every second	128Hz

Table of gate time values for TACH and SPDCON firmware revision 298

OPERATION

The Motor Mind B is a DC motor controller with a simple command set. Access to its features is based on a serial communication protocol. Because there are no external components necessary for use, the Motor Mind B is an extremely easy device to use.

Hardware Hook up

The connection diagram below shows the basic setup for using the Motor Mind B. This is the easiest and simplest way to use the Motor Mind B. Information about using the module with only one serial line is given in the **Applications** section of this data sheet.

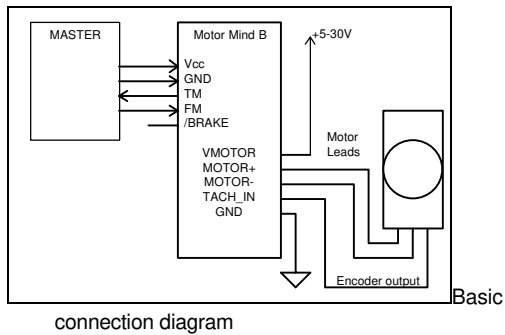

connection diagram

Power(Vcc) must be supplied to the Motor Mind B from either a master processor or an external supply. When communication is taking place between the master and the Motor Mind B, both the host's ground and the Motor Mind B's GND pin must be at the same potential. As the diagram shows, the TM pin on the Motor Mind B provides the communication path to the master from the Motor Mind B; while the FM pin on the Motor Mind B provides the communication path from the master to the Motor Mind B.

Connecting Motors

Connecting motors for control is easy. The leads on a DC motor are connected to the MOTOR+ and MOTOR- pins of the Motor Mind B. For most motors it really doesn't matter which lead goes where. If the motor is spinning the wrong direction you can either reverse the leads, or use the Motor Mind B's reverse, REV, command to change the direction of rotation.

Your motor's supply voltage should be connected to VMOTOR, and the motor supply's ground should tie in with the Motor Mind B's ground pin.

If your +5V supply is being derived from the same supply that is running your motor be sure to heavily filter the +5V supply. The Motor Mind B can be damaged or destroyed by noise induced by the motor.

POWER DISSIPATION

The power dissipation of the H-bridge driver can be approximated by using circuit values supplied by the Allegro MicroSystems Inc. data sheet for the A3952SLB motor driver chip. The power dissipation capability of the A3952SLB can be described by...

$$P_{ic} = (T_j - T_a) / R_{ic}$$

$$P_{ic} = \#transistors * V_{cesat} * I_{load} / 0.85$$

- P_{ic} = Power dissipation of the IC
- T_j = Max. IC junction temp. 150C
- T_a = Max. ambient temp. 75C
- R_{ic} = IC thermal resistance 67C/W
- $\#trans$ = #transistors turned on 2
- V_{cesat} = H-bridge saturation 0.9-1.8V
- I_{load} = Load current through H-bridge

Some of the characteristics required for these calculations can be found in the A3952SLB data sheet. Others are available from AAVID heat sinks. The following load current limitations proved valid in testing.

Maximum Current No Heat Sink

$$1.11W = 2 * V_{cesat} * I_{load} / 0.85$$

$$I_{load} = 0.85 * 1.11W / 2 * 1.2V$$

$$I_{load} = 390mA$$

Maximum Current With Heat Sink

$$4.3W = 2 * V_{cesat} * I_{load} / 0.85$$

$$I_{load} = 0.85 * 4.3W / 2 * 1.4V$$

$$I_{load} = 1.31A$$

With a cooling fan the Motor Mind B can be run at a 2.0A load continuously.

COMMUNICATION PROTOCOL

Communication with the Motor Mind B is accomplished with a two-wire (labeled TM and FM), asynchronous, serial communication technique. The FM pin carries data and commands from the master device to the Motor Mind B. The TM pin carries data and commands to the master device from the Motor Mind B.

All communication is 8N1, least significant bit first, 1 start bit, and 1 stop bit. The Motor Mind B accommodates 2400 baud. All communication must be initiated by the master processor. The Motor Mind B cannot initiate communication.

Every communication must be started with a '55'h sync byte. This allows the Motor Mind B to automatically sync on the baud rate. After this sync byte, the command may be sent along with any additional information, if necessary. The Motor Mind B will ignore all incoming data, until it sees a '55'h sync byte. Responses from the Motor Mind B to the master do not use the sync byte.

Any response that the Motor Mind B sends to the master will be at 2400 baud.

Some examples showing the use of the communication protocol and the command set are given on pages 7-10 of this data sheet.

FREQUENCY AND COUNTING

The Motor Mind B has a built in frequency counter. Access to this counter is via the TACH_IN pin. This input is used with the SPDCON, TACH and COUNT commands. This counter measures pulses that are present at the TACH_IN pin. Pulse measurements occur over a period ranging from 15.63-2000ms(The COUNT command measures until the desired count is reached). During the measurement period communication with the Motor Mind B is not possible. The Motor Mind B will maintain the last valid duty cycle received while reading the tachometer input.

The frequencies measured are calculated in 1-128Hz increments. See the table on page four for the gate time values as they relate to frequency resolution. The largest value that can be returned is a 16 bit value(65,535). Significant measurement errors can occur with frequencies greater than 62,000Hz when the counter is used for either the SPDCON or the TACH command. When used with the COUNT command errors can occur at frequencies as low as 32,000Hz.

The specified accuracy of the frequency counter is +/-5%. The frequency measurement's accuracy is partly based on the oscillator frequency in the microcontroller on board the Motor Mind B. Since this oscillator's frequency is temperature sensitive, high or low temperatures can cause changes in the frequency counters accuracy.

As mentioned earlier, the COUNT command also makes use of the TACH_IN frequency counter. The COUNT command counts every other rising edge present at the TACH_IN pin. Using the Motor Mind B with the COUNT command and rotary encoders motor positioning can be accomplished. The COUNT command is always completed with a STOP command followed by a STATUS command. The bytes returned by the STATUS command allow the master unit to know when the count has been completed.

SPEED CONTROL ADJUSTMENTS

The SPDCON command makes automatic adjustments to the duty cycle of the Motor Mind B based on the frequency measured at the TACH_IN pin. The user sets the desired motor tachometer frequency with the SPDCON command. The adjustments to duty cycle occur based on the gate time value.

See the table on page four for how the gate time value relates to the number of duty-cycle updates per second.

It should be stated that shorter gate times reduce the resolution of the SPDCON and TACH commands. Choosing the fastest gate time allows for the most responsive motor control, but the least accuracy in tachometer measurements. Some trial and error will likely be required to select the gate time value that best suits your needs.

FEATURES

Confirmation Byte - By setting the highest bit of a command byte you can have the Motor Mind B send a confirmation byte on the TM pin whenever it receives a command. The confirmation byte is 'AA'h, and is sent 500us after a valid command is received. This can be used in noisy systems as feedback for the master unit to ensure motor control is being achieved.

/BRAKE Pin - A logic low at the /BRAKE pin shuts off the H-bridge driver. This can be used as an emergency shut off switch. It does not stop the Motor Mind B from receiving or implementing communication. Logic devices pulling the pin low will have to sink 5mA of current. The /BRAKE pin can also be used to stop motors with a high gear ratio.

COMMANDS

The following descriptions detail the methods for sending commands to the Motor Mind B. If the high bit of the command byte is set then a confirmation byte will be returned.

STOP command ('00'h) To execute a STOP command the master unit sends the sync byte followed by the STOP command on the FM pin. The STOP command resets the motor speed to the lowest duty cycle(0.39%).

REV command ('01'h) The reverse command changes the direction that the motor is rotating. Motors capable of reversing direction are necessary for this command to function properly. Reversing direction at high speeds can cause back EMF spikes. Large spikes can damage electronics including the Motor Mind B. To execute this command the master unit sends the sync byte followed by the REV command on the FM pin.

TACH command ('02'h) The master sends the sync byte, followed by the TACH command on the FM pin. Note that if the highest bit of the command is set a confirmation byte will be returned. When a TACH command is acknowledged the Motor Mind waits 250ms and then sends the frequency of the signal at the TACH_IN pin to the master unit on the TM pin. This value is sent as two bytes. The high byte is sent first.

The frequency counter built into the device counts low to high transitions at the TACH_IN pin. This count occurs over a period of 250ms, in default mode.

Firmware revision 298 allows a gate time value to be sent as a third byte. This gate time value selects the period over which a tachometer measurement takes place. Increased frequency resolution is available by using longer gate time periods. Faster measurements can be accomplished by using a shorter gate time. See the table on page four for the eight gate times available. If no gate time value is sent, then the Motor Mind B defaults to one measurement every 250ms.

In order to increase tachometer accuracy the SPDCON and TACH PWM frequency now operates at 64Hz.

SETDC command ('03'h) To adjust motor speed the master unit sends the sync byte followed by the SETDC command on the FM pin. The command is then followed by the positive duty cycle value. The range is '00'h-'FF'h(0-255dec.). The minimum duty cycle is 0.39%, the maximum is 99.61%. While the Motor Mind B accepts 256 discrete steps, '00'h is implemented as a '01'h, and 'FF'h as a 'FE'h. So the actual number of PWM steps available is 254. The higher the number the faster the motor will turn.

SPDCON command ('04'h) Send the Motor Mind B a sync byte and the speed control command, '04'h, followed by the high byte then low byte of the frequency desired. The Motor Mind B will read in the tachometer signal and adjust the duty cycle of the motor until the tachometer matches the desired frequency. Speed adjustments occur roughly 4 times per second. Once in speed control mode the Motor Mind B will ignore any further communications. The only way to exit speed control mode is to pull the FM pin low for a period greater than 250ms(See next paragraph for rev. 298 information). When the FM pin is returned high the Motor Mind B will re-enter its normal operating mode. The last duty cycle adjustment implemented by the Motor Mind B will continue to be executed after exiting the speed control mode.

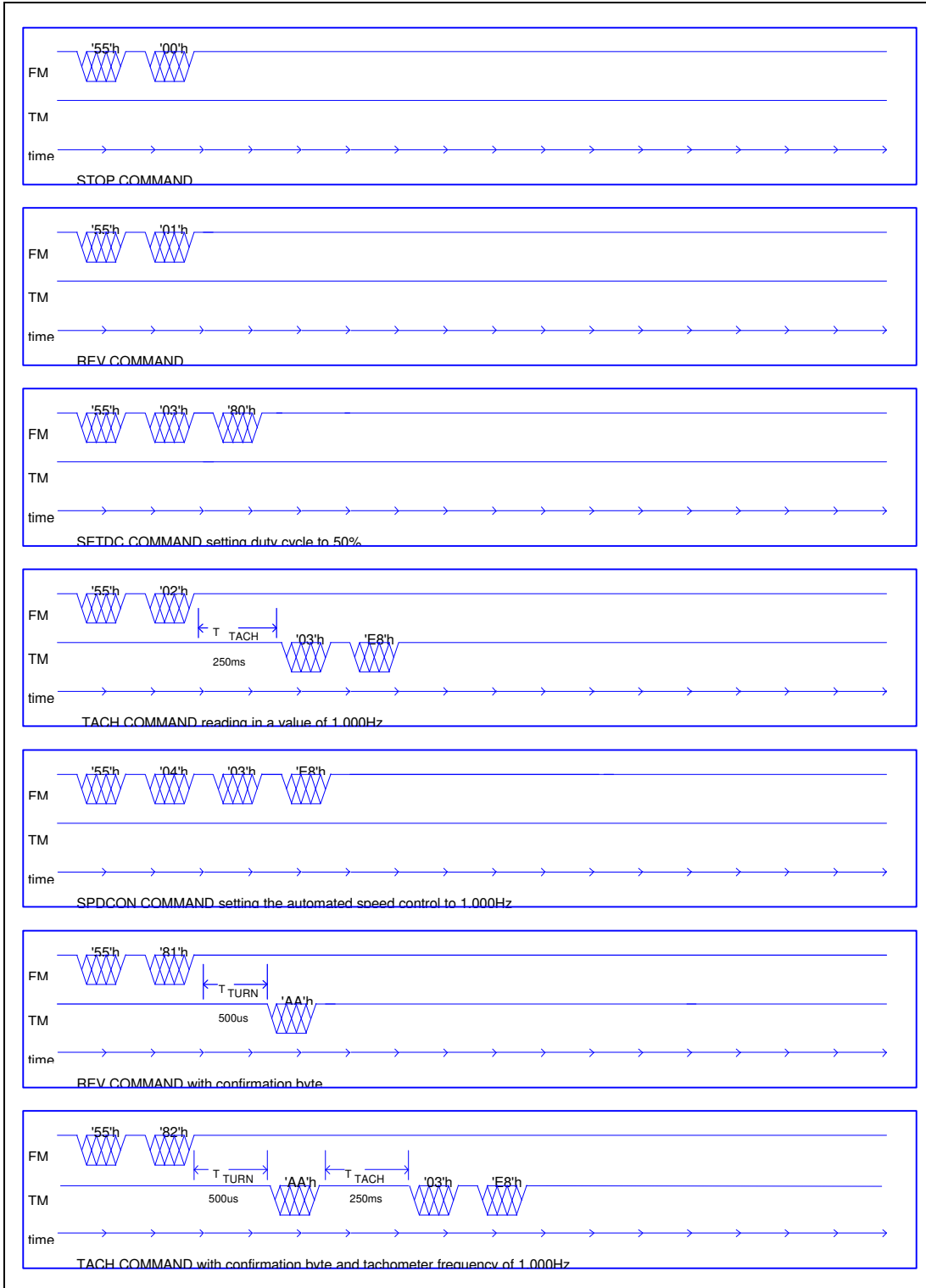

Command Set and Communication Examples

The SPDCON command has been updated in firmware revision 298. The number of duty cycle updates per second can be adjusted by including a gate time value byte as the last byte sent by the SPDCON command. In other words, you send the sync byte, followed by the high frequency, low frequency, and the gate time value. Eight gate time values are available. Gate time values may be seen on the table located on page four of this data sheet. The SPDCON operates at 64Hz to allow for improved frequency measurements. To exit the SPDCON command mode simply pull the FM pin low for a period greater than the gate time. The gate time for a particular gate time value can also be found in the table on page four.

STATUS command ('05'h) The STATUS command is an additional command available with firmware revision 298. The STATUS command consists of the sync byte followed by the command byte. A confirmation byte may also be requested in conjunction with the STATUS command. If a confirmation is requested it will be the first byte returned by the Motor Mind B. Upon receiving the STATUS command the Motor Mind B will return two bytes.

The first byte is the status byte. Bit zero of this byte is the motor direction flag. If bit zero is clear then the Motor Mind B is configured to turn the motor in its forward direction. If bit zero is set then the motor is reversed. Bit one of the status byte is the processor reset flag. If the processor has executed a watch-dog timer reset then bit one will be set.

Examples-

- status byte = B'0000 0000' → forward
- status byte = B'0000 0001' → reverse
- status byte = B'0000 0010' → reset

The second byte returned by the STATUS command is the duty cycle byte. This value is the current duty cycle being implemented by the Motor Mind B. This can be useful after exiting the SPDCON command to determine the current motor speed.

COUNT command ('06'h) The COUNT command is an additional command introduced with firmware revision 298. The COUNT command consists of four bytes. The first is the sync byte, followed by the high count byte, low count byte, and desired duty cycle. As with all other commands a confirmation byte can be requested by setting the highest bit of the command byte.

The COUNT command sets the duty cycle in the Motor Mind B to the desired value as sent by the COUNT command. The Motor Mind B will then count rising edges at the TACH_IN pin of the module. When the number of rising edges equals the desired count, the Motor Mind B will execute a STOP command. It will then return a STATUS command to the master unit.

The COUNT command will only count an even number of rising edges. You may send any value from 0-65,535. The Motor Mind B will round the count down to the next even value. Errors in counting can be introduced by noise, and counting rising edges of frequencies greater than 32,000Hz.

The COUNT command can be used with motor encoders to create rudimentary motor positioning systems. Keep in mind that when using higher duty cycle values the motor will continue to rotate for a period after a STOP command has been issued.

Once a COUNT has been executed communication with the Motor Mind B is not possible until the count has been completed. If a situation could occur where a count can not be completed (such as your motor is stalled), a method of resetting the Motor Mind B by the master unit should be designed into your system. Switching on-off the +5V supply is one method.

Command Structure

note: all values in hexadecimal unless otherwise noted.

Command	Byte Sent
STOP	'00'h
STOP(with confirmation)	'80'h
REV	'01'h
REV(with confirmation)	'81'h
TACH*	'02'h
TACH(with confirmation)*	'82'h
SETDC	'03'h
SETDC(with confirmation)	'83'h
SPDCON*	'04'h
SPDCON(with confirmation)*	'84'h
STATUS*	'05'h
STATUS(with confirmation)*	'85'h
COUNT*	'06'h
COUNT(with confirmation)*	'86'h

Table of Commands * = firmware rev. 298 additions

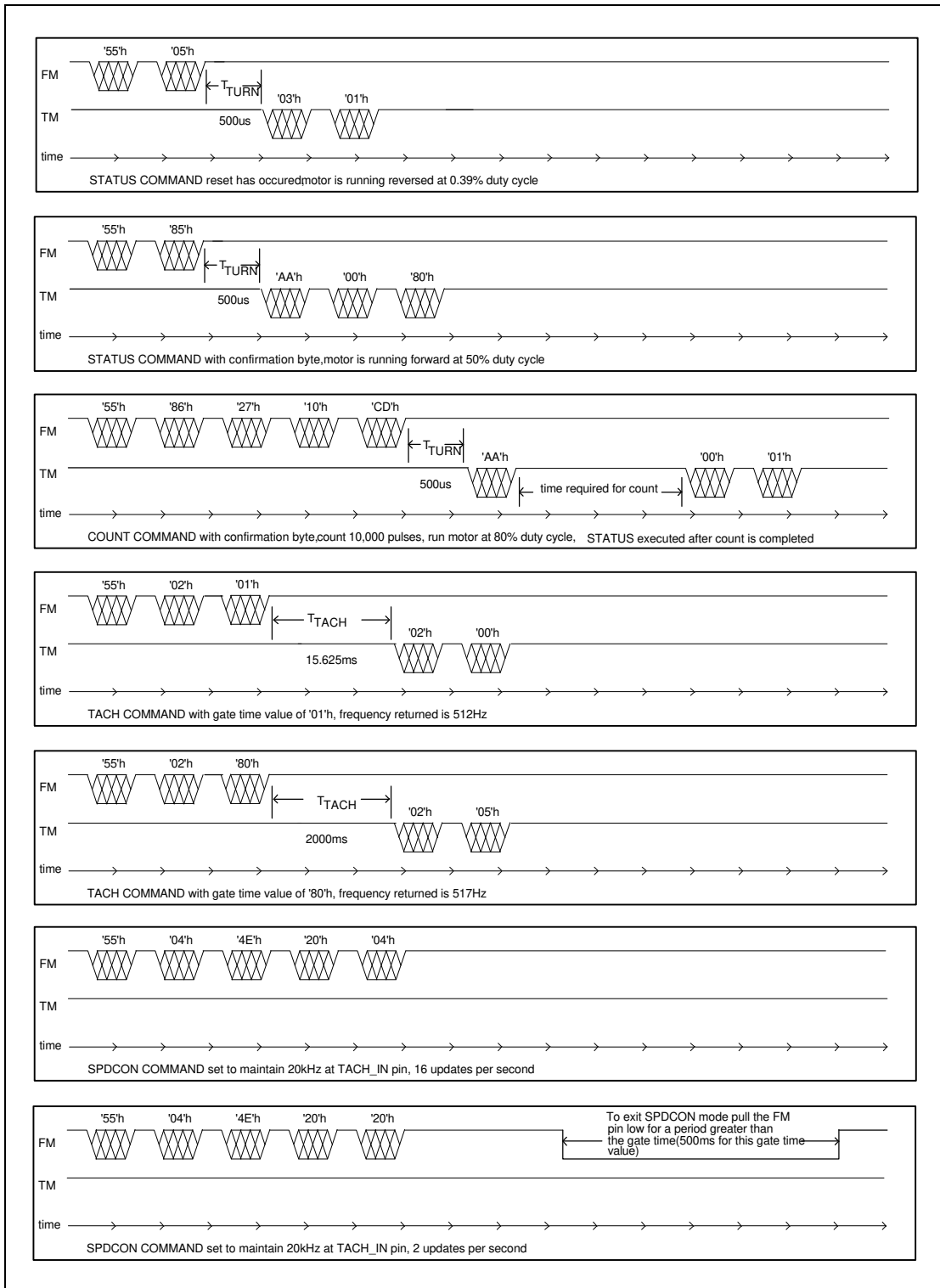

Command Set and Communication Examples; firmware revision 298

APPLICATIONS

The following examples show how to interface the Motor Mind B to various master processors in various configurations. AN-254 steps through most of the module's commands, AN-255 is a code fragment showing the COUNT command with a BSII, AN-252 'Interfacing with a single wire', and the hardware diagram for AN-253 'Interfacing to a PC' are detailed here.

AN-254 Using the Motor Mind B SETDC, TACH, STOP, SPDCON, STATUS, commands, and confirmation byte, with a Parallax BASIC Stamp2

This application note cycles through most of the commands available to the user in the Motor Mind B. Each command makes use of the confirmation byte. To disable the confirmation byte function, simply change the highest bit in the command byte to zero. For instance, to send a STOP command with a confirmation byte returned to the Stamp you would send the value '80'h(binary '1000 0000'). To send a STOP command and tell the Motor Mind B not to return a confirmation byte you would send the command '00'h(binary '0000 0000').

The first leg of this routine sends a STOP command with a request for a confirmation byte, '80'h. The routine will then display "STOP" to the debug terminal. After the STOP command is received the Motor Mind will reduce the duty cycle to 0.39%, and pause for 3 seconds.

When the pause is complete, the routine sends the SETDC command with a request for a confirmation byte, '83'h, with a duty cycle of 'DD'h. The routine will then display "SETDC" to the debug terminal. After the SETDC command is received the Motor Mind will increase the duty cycle to 86.2%, and pause for 3 seconds.

Command three is the TACH command. The tachometer input circuit is accurate up to roughly 62KHz. Once the confirmation byte is received the frequency is being measured by the Motor Mind B. After a two seconds the frequency will be returned to the debug screen. The high byte is returned first, followed immediately by the low byte. This value, while in hex format, has already been converted to frequency for you. Take note of the extended period that SERIN will wait for returned data after a TACH command is sent. After the tachometer frequency is received this routine pauses for 3 seconds. This give you ample time to wonder at the neatness of it all.

Command number four is the SPDCON command, '84'h('04'h without a confirmation request). When sent, this command is accompanied by three bytes of data. The first is the high frequency byte, followed by the low frequency byte, and last is the gate time value byte. A confirmation byte is returned after all bytes have been received by the Motor Mind B. Once in speed control mode the Motor Mind B will continuously read the tachometer and adjust the duty cycle so that the tachometer frequency meets that of the SPDCON frequency. Adjustments in duty cycle are made in 0.39% increments/decrements and occur 64 times per second. The duty cycle will not be reduced below 0.39% or increased beyond 99.61% regardless of the tachometer input.

In this routine the frequency sent by the SPDCON command is 2,500Hz, the routine will maintain this mode for 60 seconds. To get out of the speed control mode the FM line must be pulled low for at least the gate time (at least 15.63ms for this gate time value). After which if you return the FM line high for 25ms, the Motor Mind B will be running in it's normal program mode. In other words, if you use the speed control mode, the Motor Mind B will not acknowledge any more commands from the master unit until it is released from the speed control mode using the method detailed above.

Command five is the STATUS command. It will return two bytes to the master unit. The first is the status byte which maintains the motor direction flag, and a reset flag. The second byte is the current duty cycle being implemented by the Motor Mind B.

Hook-up Diagram

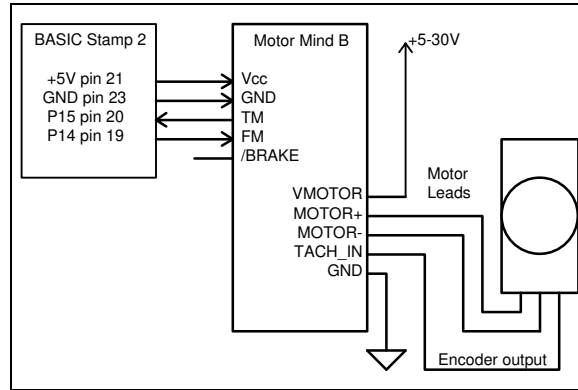

AN-254 Code Listing

'AN-254 is a modified version of AN-251. It makes use of the gate time values available in the Motor Mind B firmware 'revision 298. This routine uses the most accurate TACH gate time value, as well as the fastest SPDCON gate time 'value. This routine steps through most of the command set available to users of the Motor Mind B. The routine will loop 'through itself roughly every 75 seconds. The confirmation byte and DEBUG routine are used to signal the user that a 'new command has been sent to and received by the Motor Mind B.

```
OUTPUT 14
INPUT 15
```

```
TM CON 15
FM CON 14
HIGH FM
```

```
START_UP:
    PAUSE 1000
```

```
'Send STOP command
```

```
    SEROUT FM,396,[$55,$80]
    SERIN TM,396,100,NO_CONFIRM1,[b7]
    IF b7 <> $AA THEN NO_CONFIRM1
```

```
CONFIRM1:
    DEBUG "STOP",CR
```

```
NO_CONFIRM1:
    PAUSE 3000
```

```
'Send SETDC command, set duty cycle to 'DD'h, or 86.2%,(Dec 221 out of 256 possible)
```

```
    SEROUT FM,396,[$55,$83,$DD]
    SERIN TM,396,100,NO_CONFIRM2,[b7]
    IF b7 <> $AA THEN NO_CONFIRM2
```

```
CONFIRM2:
    DEBUG "SETDC",CR
```

```
NO_CONFIRM2:
    PAUSE 3000
```

```
'Send TACH command and read back/display tachometer frequency. Gate time = 2000ms
```

```
    SEROUT FM,396,[$55,$82,$80]
    SERIN TM,396,3000,NO_CONFIRM3,[b7,b8, b9]
    IF b7 <> $AA THEN NO_CONFIRM3
```

```
CONFIRM3:
    DEBUG "TACH VALUE = "
    DEBUG ISHEX2 b8
    DEBUG ISHEX2 b9,CR
```

```
NO_CONFIRM3:
    PAUSE 3000
```



```
'Send SPDCON command, freq. set to 2500Hz('09C4'h) maintain for 60s; 64 updates/s
```

```

    SEROUT FM,396,[$55,$84,$09,$C4,$01]
    SERIN  TM,396,100,NO_CONFIRM4,[b7]
    IF b7 <> $AA THEN NO_CONFIRM4
CONFIRM4:
    DEBUG  "SPDCON MODE",CR
NO_CONFIRM4:
    PAUSE  60000
'Exit SPDCON mode hold FM pin low for longer than gate time
    LOW   FM
    PAUSE 16
    HIGH  FM
    PAUSE 25

```

```
'Send STATUS command
```

```

    SEROUT FM,396,[$55,$85]
    SERIN  TM,396,100,NO_CONFIRM5,[b7,b8,b9]
    IF b7 <> $AA THEN NO_CONFIRM5
CONFIRM5:
    DEBUG  "STATUS ",CR
    DEBUG  "status byte ", ISHEX2 b8,TAB
    DEBUG  "duty cycle ", ISHEX2 b9,CR
NO_CONFIRM5:
    PAUSE  3000
'Return to normal operating mode
    DEBUG  "DONE",CR
    GOTO   START_UP
END:

```

AN-255 COUNT Command example

The following code fragment is an example of how the COUNT command can be implemented.

```
'AN-255 Count 10000 pulses, duty cycle is set for 12.5%
    SEROUT FM,396,[$55,$06,$27,$10,$20]
    SERIN  TM,396,10000,NO_DATA[b8,b9]           'COUNT returns a STATUS when done
    DEBUG  "STATUS ",CR
    DEBUG  "status byte ", ISHEX2 b8,TAB         'Display status byte
    DEBUG  "duty cycle ", ISHEX2 b9,CR         'Display duty cycle byte
NO_DATA:
```

AN-252 Interfacing with 1 I/O line

The Motor Mind B uses a two wire serial interface for communication. However, its TM pin is pseudo open-collector. This coupled with the fact that the FM pin and the TM pin never communicate simultaneously allows the Motor Mind B to communicate via 1 wire if the master processor is able to support this mode.

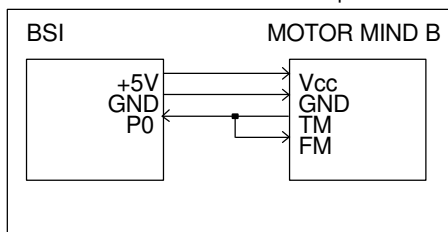

In order for 1 wire communication to work, the master processor must be able to both send and receive with one I/O line. Because of this, a standard PC serial port is not able to work with just 1 wire. However, most microcontrollers can support this mode. This example shows how to interface the Motor Mind B to a Parallax BASIC Stamp I with only one wire. The diagram to the left shows the connections necessary. Connections to the motor control pins are identical to those of other application notes. The following code gives a brief listing some BSI instructions which will support this method of communication.

```

'AN-252 Declare variables
START:
SYMBOL CONFIRM      =      B1      'Will hold confirmation byte
SYMBOL TM           =      0       'To Master (data from Motor Mind)
SYMBOL FM           =      0       'From Master (data to Motor Mind)
B2                  =      $80     'B2 = DUTY CYCLE REGISTER
HIGH 0
PAUSE 500           'Make sure FM pin is high
                        'Pause 500ms
SETDC:
SEROUT 0,T2400,($55,$03,B2)      'Use SETDC command
PAUSE 1000

REV:
SEROUT 0,T2400,($55,$81)         'Use REV command
SERIN 0,T2400,CONFIRM           'Read in confirmation
IF CONFIRM <> $AA THEN REV
PAUSE 100
DEBUG "REVERSED",CR

STOP:
PAUSE 1000
SEROUT 0,T2400,($55,$80)         'Use STOP command
SERIN 0,T2400,CONFIRM           'Read in confirmation
IF CONFIRM <> $AA THEN STOP
PAUSE 100
DEBUG "STOPPED",CR
B2 = 0

SETDC2:
SEROUT 0,T2400,($55,$03,B2)     'Adjust duty cycle
B2 = B2 +5                       'Increment by 5s
PAUSE 100
DEBUG B2,CR
IF B2 <> $FF THEN SETDC2

STOP2:
PAUSE 1000
SEROUT 0,T2400,($55,$80)         'Use STOP command
SERIN 0,T2400,CONFIRM           'Read in confirmation
IF CONFIRM <> $AA THEN STOP
DEBUG "DONE",CR

END:
    
```

AN-253 Interfacing to a PC Serial Port

The Motor Mind B can be easily interfaced to a PC serial port, thereby allowing any PC program which can control the serial port to interface to the Motor Mind B. The two wire interface of the Motor Mind allows for two way communication with no special hardware configuration.

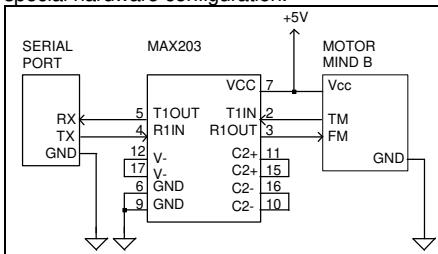

The schematic shows a Maxim 203 RS-232 level translator chip for changing the TTL levels of the Motor Mind B to RS-232 levels. While there are methods available of interfacing to RS-232 levels without a level translation chip, Solutions Cubed can make no claims as to their reliability.

For a standard PC serial port use the following pin out for the serial connector. These connections should work with most computers, but you should check to make sure.

Signal Name	DB-25	DB-9
TX	2	3
RX	3	2
GND	7	5

Distributors

Digi Key

701 Brooks Ave. South
Thief River Falls, MN 56701-0677
800-344-4539
www.digikey.com

Jameco

1355 Shoreway Road
Belmont, CA 94002-4100
800-831-4242
www.jameco.com

JDR Microdevices

1850 South 10th Street
San Jose, CA 95112-4108
800-538-5000
www.jdr.com

Mondo-tronics

4286 Redwood Hwy #226
San Rafael, CA 94960
415-491-4600
www.mondo.com

Parallax

3805 Atherton Road, #102
Rocklin, CA 95765
888-512-1024
www.parallaxinc.com

Tech America

P.O. Box 1981
Fort Worth, TX 76101-1981
800-877-0072
www.techam.com



Disclaimer of Liability and Accuracy: Information provided by Solutions Cubed is believed to be accurate and reliable. However, Solutions Cubed assumes no responsibility for inaccuracies or omissions. Solutions Cubed assumes no responsibility for the use of this information and all use of such information shall be entirely at the user's own risk.

Life Support Policy: Solutions Cubed does not authorize any Solutions Cubed product for use in life support devices and/or systems without express written approval from Solutions Cubed.

Warranty: Solutions Cubed warrants all Miniature Engineering Modules against defects in materials and workmanship for a period of 90 days. If you discover a defect, we will, at our option, repair or replace your product or refund your purchase price. This warranty does not cover Miniature Engineering Modules which have been physically abused or misused in any way.