



Chipsmall Limited consists of a professional team with an average of over 10 year of expertise in the distribution of electronic components. Based in Hongkong, we have already established firm and mutual-benefit business relationships with customers from,Europe,America and south Asia,supplying obsolete and hard-to-find components to meet their specific needs.

With the principle of "Quality Parts,Customers Priority,Honest Operation,and Considerate Service",our business mainly focus on the distribution of electronic components. Line cards we deal with include Microchip,ALPS,ROHM,Xilinx,Pulse,ON,Everlight and Freescale. Main products comprise IC,Modules,Potentiometer,IC Socket,Relay,Connector.Our parts cover such applications as commercial,industrial, and automotives areas.

We are looking forward to setting up business relationship with you and hope to provide you with the best service and solution. Let us make a better world for our industry!



Contact us

Tel: +86-755-8981 8866 Fax: +86-755-8427 6832

Email & Skype: info@chipsmall.com Web: www.chipsmall.com

Address: A1208, Overseas Decoration Building, #122 Zhenhua RD., Futian, Shenzhen, China



Type 2 surge protection plug - VAL-US 240 ST - 2800740

Please be informed that the data shown in this PDF Document is generated from our Online Catalog. Please find the complete data in the user's documentation. Our General Terms of Use for Downloads are valid (<http://phoenixcontact.com/download>)



Surge protection connector type 2 with high-capacity varistor for VAL-MS base element, thermal monitoring, visual fault warning. Design: 240 V AC

The figure shows the VAL-US 347 ST version



Key commercial data

Packing unit	1 pc
Weight per Piece (excluding packing)	44.0 GRM
Custom tariff number	85363090
Country of origin	Germany

Technical data

Dimensions

Height	52.4 mm
Width	17.5 mm
Depth	55.3 mm

Ambient conditions

Degree of protection	IP20
Ambient temperature (operation)	-40 °C ... 80 °C
Ambient temperature (storage/transport)	-40 °C ... 80 °C
Altitude	≤ 2000 m (amsl (above mean sea level))
Permissible humidity (operation)	5 % ... 95 %
Shock (operation)	25g
Vibration (operation)	5g

General

Standards/specifications	IEC 61643-11 2011
	EN 61643-11 2012

Type 2 surge protection plug - VAL-US 240 ST - 2800740

Technical data

General

IEC test classification	II
	T2
EN type	T2
SPD design	Voltage-limiting type
Mode of protection	L-PEN
	L-N
Mounting type	On base element
Color	black
Housing material	PA 6.6
Pollution degree	2
Inflammability class according to UL 94	V-0
Type	Male
Number of positions	1
Arrester can be tested with CHECKMASTER from software version:	From SW rev. 1.10
Surge protection fault message	Optical

Protective circuit

Nominal voltage U_N	240/415 V AC (TN)
	240/415 V AC (TT)
Nominal frequency f_N	60 Hz (50 Hz)
Maximum continuous operating voltage U_C	275 V AC
Residual current I_{PE}	≤ 0.45 mA
Standby power consumption P_C	≤ 120 mVA
Nominal discharge current I_n (8/20) μ s	20 kA
Maximum discharge current I_{max} (8/20) μ s	40 kA
Short-circuit current rating I_{SCCR}	25 kA
Voltage protection level U_p	≤ 1.35 kV
Residual voltage U_{res}	≤ 1.35 kV (at I_n)
	≤ 1.1 kV (at 10 kA)
	≤ 1 kV (at 5 kA)
	≤ 0.9 kV (at 3 kA)
TOV behavior at U_T	335 V AC (5 s / withstand mode)
	440 V AC (120 min / safe failure mode)
Response time t_A	≤ 25 ns
Max. backup fuse with branch wiring	125 A AC (gG)

Connection data

Connection method	VALVETRAB plug-in system
-------------------	--------------------------

Type 2 surge protection plug - VAL-US 240 ST - 2800740

Technical data

NEMA/UL protective circuit

UL class	Type 4 SPD for Type 2 applications
Maximum continuous operating voltage MCOV (L-N)	275 V AC
Nominal voltage U_N	240 V AC
Mode of protection	L-N
Power distribution system	1
Nominal frequency	50/60 Hz
Voltage protection rating VPR (L-N)	0.9 kV
Nominal discharge current I_n (L-N)	20 kA

Classifications

eCl@ss

eCl@ss 4.0	27140201
eCl@ss 4.1	27130801
eCl@ss 5.0	27130801
eCl@ss 5.1	27130801
eCl@ss 6.0	27130803
eCl@ss 7.0	27130803
eCl@ss 8.0	27130803

ETIM

ETIM 3.0	EC000472
ETIM 4.0	EC000472
ETIM 5.0	EC000472

UNSPSC

UNSPSC 6.01	30212010
UNSPSC 7.0901	39121610
UNSPSC 11	39121610
UNSPSC 12.01	39121610
UNSPSC 13.2	39121620

Approvals

Approvals

Approvals

UL Recognized / cUL Recognized / CSA / cULus Recognized

Type 2 surge protection plug - VAL-US 240 ST - 2800740

Approvals

Ex Approvals

Approvals submitted

Approval details

UL Recognized

cUL Recognized

CSA

cULus Recognized

Drawings

Dimensioned drawing

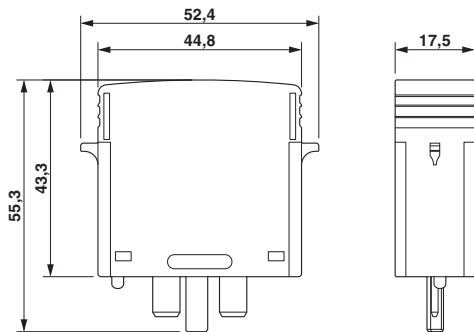

Circuit diagram

