



Chipsmall Limited consists of a professional team with an average of over 10 year of expertise in the distribution of electronic components. Based in Hongkong, we have already established firm and mutual-benefit business relationships with customers from,Europe,America and south Asia,supplying obsolete and hard-to-find components to meet their specific needs.

With the principle of “Quality Parts,Customers Priority,Honest Operation,and Considerate Service”,our business mainly focus on the distribution of electronic components. Line cards we deal with include Microchip,ALPS,ROHM,Xilinx,Pulse,ON,Everlight and Freescale. Main products comprise IC,Modules,Potentiometer,IC Socket,Relay,Connector.Our parts cover such applications as commercial,industrial, and automotives areas.

We are looking forward to setting up business relationship with you and hope to provide you with the best service and solution. Let us make a better world for our industry!



Contact us

Tel: +86-755-8981 8866 Fax: +86-755-8427 6832

Email & Skype: info@chipsmall.com Web: www.chipsmall.com

Address: A1208, Overseas Decoration Building, #122 Zhenhua RD., Futian, Shenzhen, China



Surge protection connector - UFBK-M 2-PE- 24DC-ST - 2817055

Please be informed that the data shown in this PDF Document is generated from our Online Catalog. Please find the complete data in the user's documentation. Our General Terms of Use for Downloads are valid (<http://download.phoenixcontact.com>)



Protective plug UFBK-M with two conductor protection in floating signal circuits. Nominal voltage: 24 V DC



Key commercial data

Packing unit	1
Minimum order quantity	1
GTIN	 4 017918 129828
Custom tariff number	85363010
Country of origin	GERMANY

Technical data

General

Housing material	PA
Inflammability class according to UL 94	V2
Ambient temperature (operation)	-40 °C ... 80 °C
Degree of protection	IP20
Arrester can be tested with TT-Tester from software version:	From SW rev. 6.00
Arrester can be tested with CHECKMASTER from software version:	From SW rev. 1.00
Pitch unit	1 Div.

Protective circuit

Nominal voltage UN	24 V DC
Nominal current IN	2 A
Operating effective current IC at UC	100 µA
Nominal discharge surge current In (8/20) µs (Core-Core)	10 kA
Nominal discharge surge current In (8/20) µs (Core-Earth)	10 kA
Output voltage limitation at 1 kV/µs (Core-Core) static	(<1,8 Umax)
Output voltage limitation at 1 kV/µs (Core-Earth) static	≤ 550 V
Response time tA (Core-Core)	≤ 1 ns
Response time tA (Core-Earth)	≤ 100 ns

Surge protection connector - UFBK-M 2-PE- 24DC-ST - 2817055

Technical data

Protective circuit

Resistance in series	< 100 mΩ (Path 1-3)
Resistance in series	< 100 mΩ (Path 2-4)

Connection data

Connection method	Screw connection
Screw thread	M3
Stripping length	8 mm
Conductor cross section stranded min.	0.2 mm ²
Conductor cross section stranded max.	2.5 mm ²
Conductor cross section solid min.	0.2 mm ²
Conductor cross section solid max.	4 mm ²
Conductor cross section AWG/kcmil min.	24
Conductor cross section AWG/kcmil max	12

Classifications

eclass

eCl@ss 4.0	27140201
eCl@ss 4.1	27130801
eCl@ss 5.0	27130801
eCl@ss 5.1	27130801
eCl@ss 6.0	27130807

etim

ETIM 2.0	EC000943
ETIM 3.0	EC000943
ETIM 4.0	EC000943

unspsc

UNSPSC 6.01	30212010
UNSPSC 7.0901	39121610
UNSPSC 11	39121610
UNSPSC 12.01	39121610
UNSPSC 13.2	39121620

Drawings

Surge protection connector - UFBK-M 2-PE- 24DC-ST - 2817055

Dimensioned drawing

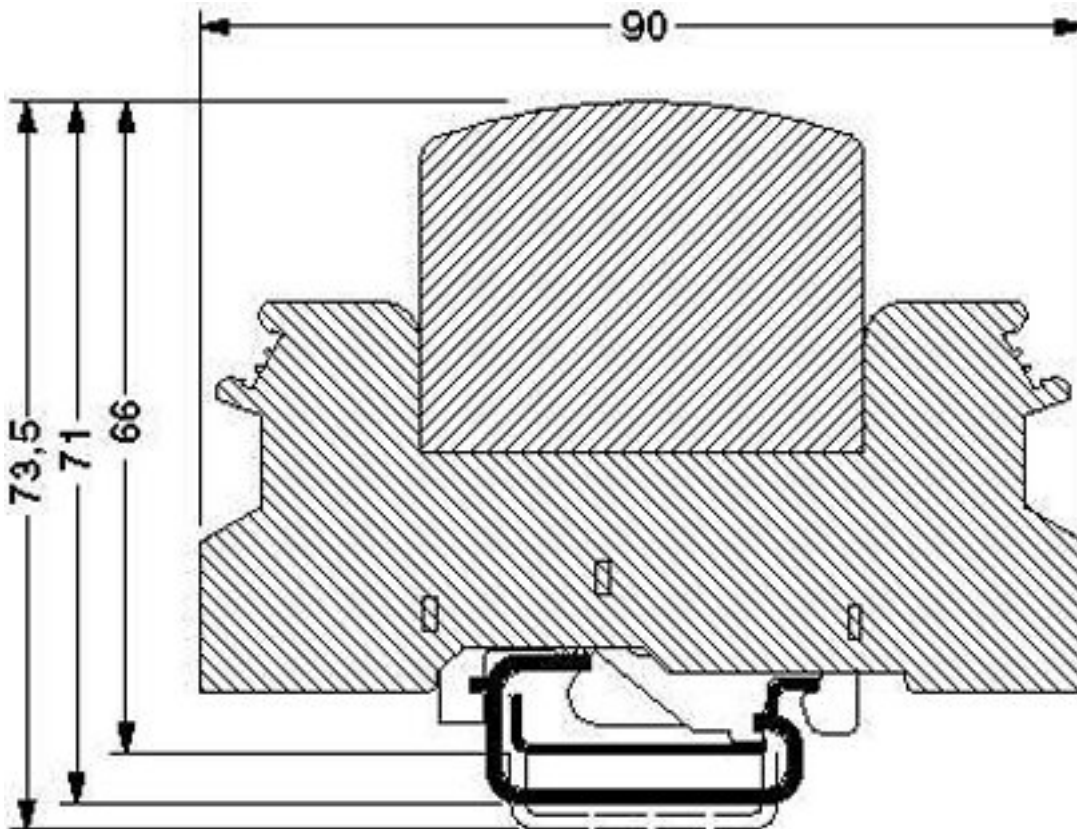

Circuit diagram

