



Chipsmall Limited consists of a professional team with an average of over 10 year of expertise in the distribution of electronic components. Based in Hongkong, we have already established firm and mutual-benefit business relationships with customers from,Europe,America and south Asia,supplying obsolete and hard-to-find components to meet their specific needs.

With the principle of "Quality Parts,Customers Priority,Honest Operation,and Considerate Service",our business mainly focus on the distribution of electronic components. Line cards we deal with include Microchip,ALPS,ROHM,Xilinx,Pulse,ON,Everlight and Freescale. Main products comprise IC,Modules,Potentiometer,IC Socket,Relay,Connector.Our parts cover such applications as commercial,industrial, and automotives areas.

We are looking forward to setting up business relationship with you and hope to provide you with the best service and solution. Let us make a better world for our industry!



Contact us

Tel: +86-755-8981 8866 Fax: +86-755-8427 6832

Email & Skype: info@chipsmall.com Web: www.chipsmall.com

Address: A1208, Overseas Decoration Building, #122 Zhenhua RD., Futian, Shenzhen, China



4

3

2

1

THIS DRAWING IS UNPUBLISHED. RELEASED FOR PUBLICATION 20

© COPYRIGHT 20 Tyco Electronics AMP GmbH ALL RIGHTS RESERVED.

LOC FT DIST 0

REVISIONS

P	LTR	DESCRIPTION	DATE	DWN	APVD
	C1	REVISED PER ECO-12-007964	02MAY2012	KH	MS

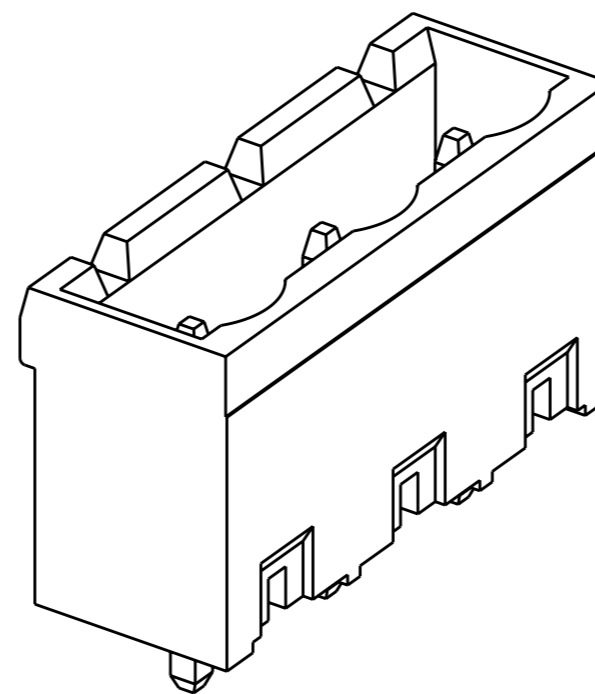
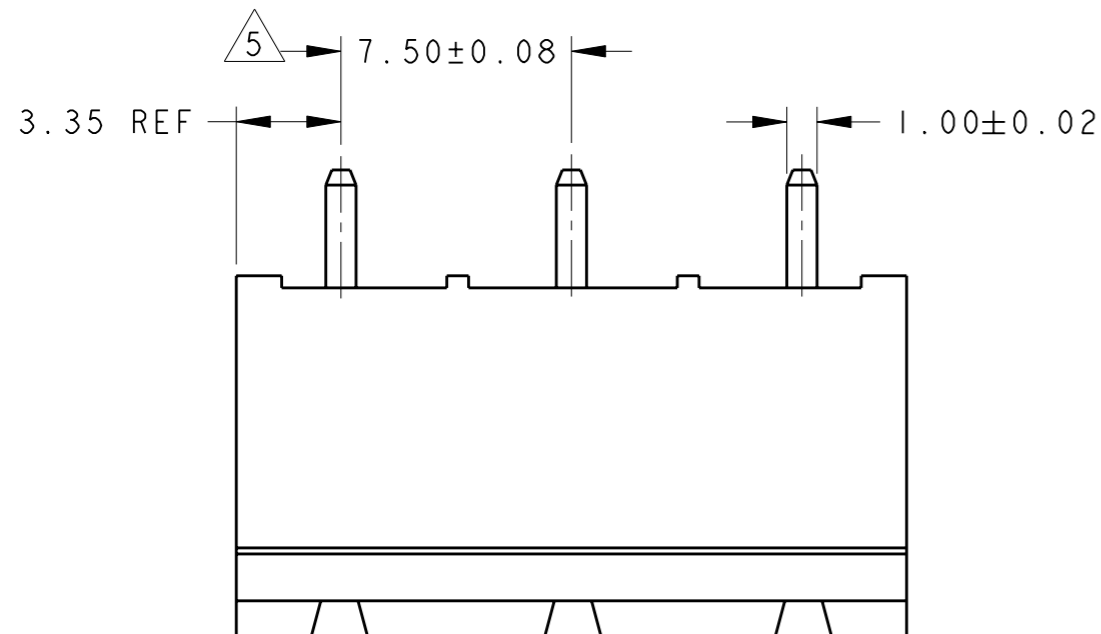

282964-3 AS SHOWN

- 1 MATERIALS AND FINISH
HOUSING: PA 6-6, UL 94-V0, COLOR GREEN.
TERMINAL: COPPER ALLOY, TIN PLATED.
- 2 SUITABLE FOR 1,6-2,4mm PC BOARD THICKNESS.
- 3 RECOGNIZED UNDER THE COMPONENT PROGRAM OF UNDERWRITERS LABORATORIES INC. FILE N° E60677.
- 4 IMQ CERTIFICATE WITH SURVEILLANCE IN CONFORMITY WITH IEC 998-1/998-2-1.
- 5 NOT CUMULATIVE TOLERANCE.

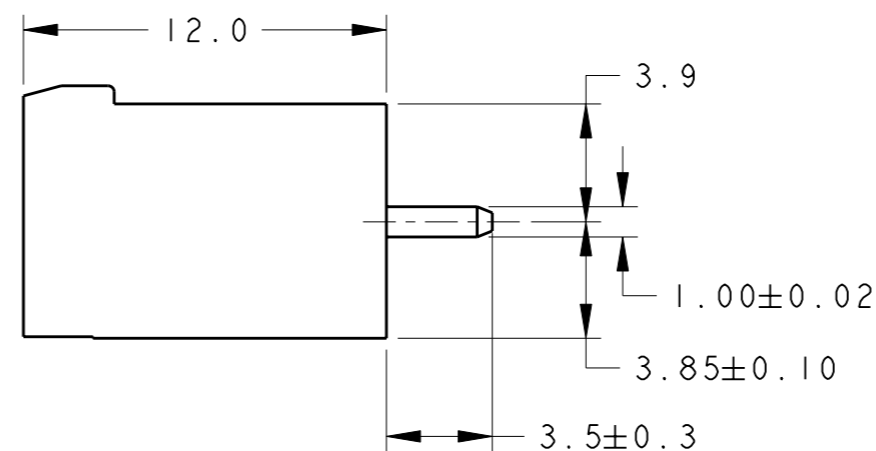
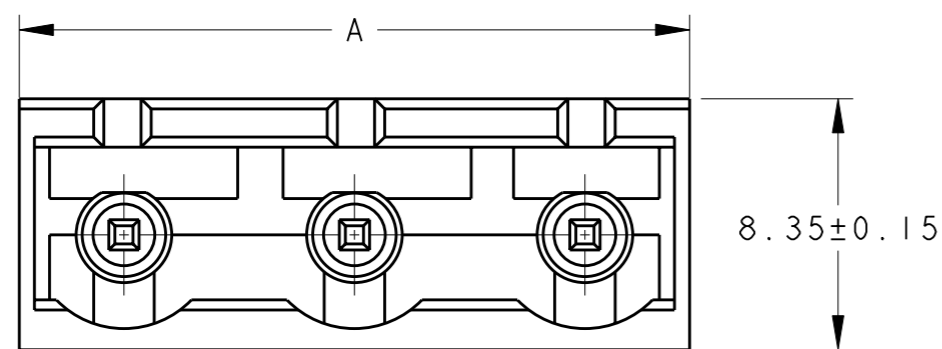

89.20	12	1-282964-2
81.70	11	1-282964-1
74.20	10	1-282964-0
66.70	9	282964-9
59.20	8	282964-8
51.70	7	282964-7
44.20	6	282964-6
36.70	5	282964-5
29.20	4	282964-4
21.70	3	282964-3
14.20	2	282964-2
DIM. A	N° OF POS.	PART NUMBER

RECOMMENDED PC BOARD LAYOUT

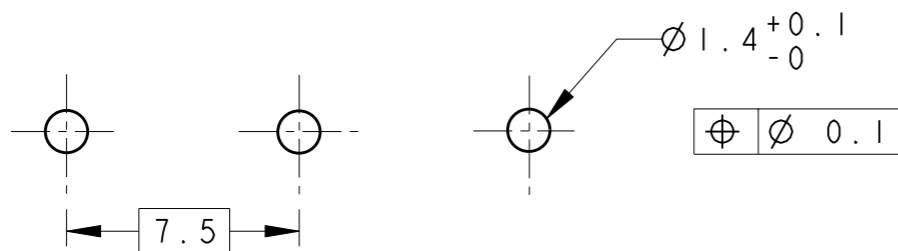

THIS DRAWING IS A CONTROLLED DOCUMENT.		DWN E. ZANOLINI 14DEC2001	TE Connectivity	
DIMENSIONS: mm		CHK D. BIEVENOUR 14DEC2001		
TOLERANCES UNLESS OTHERWISE SPECIFIED:		APVD D. BIEVENOUR 14DEC2001	NAME	
0 PLC ±.3		PRODUCT SPEC 108-20166	TERMINAL BLOCK, HEADER ASSEMBLY	
1 PLC ±.25		APPLICATION SPEC 114-20079	180 DEGREE CLOSED ENDS	
2 PLC ±.		WEIGHT -	SIZE A3	CAGE CODE 00779
3 PLC ±.		CUSTOMER DRAWING	DRAWING NO C-282964	RESTRICTED TO -
4 PLC ±.			SCALE 4:1	SHEET 1 OF 1
ANGLES ±2				
MATERIAL	FINISH			