



Chipsmall Limited consists of a professional team with an average of over 10 year of expertise in the distribution of electronic components. Based in Hongkong, we have already established firm and mutual-benefit business relationships with customers from,Europe,America and south Asia,supplying obsolete and hard-to-find components to meet their specific needs.

With the principle of "Quality Parts,Customers Priority,Honest Operation,and Considerate Service",our business mainly focus on the distribution of electronic components. Line cards we deal with include Microchip,ALPS,ROHM,Xilinx,Pulse,ON,Everlight and Freescale. Main products comprise IC,Modules,Potentiometer,IC Socket,Relay,Connector.Our parts cover such applications as commercial,industrial, and automotives areas.

We are looking forward to setting up business relationship with you and hope to provide you with the best service and solution. Let us make a better world for our industry!



Contact us

Tel: +86-755-8981 8866 Fax: +86-755-8427 6832

Email & Skype: info@chipsmall.com Web: www.chipsmall.com

Address: A1208, Overseas Decoration Building, #122 Zhenhua RD., Futian, Shenzhen, China



PART NAME: KNOB

SCALE: 1:1

DATE: 5/20/86

DR. BY HD

THIS DRAWING IS THE PROPERTY OF DAVIES MOLDING COMPANY, IS SUBMITTED SOLELY AS A DESIGN OR ENGINEERING PROJECT. WE ACCEPT NO RESPONSIBILITY WHATSOEVER FOR THE PRACTICAL APPLICATION OF THE PIECES MADE TO THIS DESIGN.



DESIGNERS & MANUFACTURERS OF KNOBS, HANDLES, CASES & CUSTOM PLASTIC COMPONENTS

P/N 2830-U

M^{NO.} 2890-2830

CAVITY	2830
PLUNGER	2830
PLUNGER PIN	2830
PINS	3000-F
LANDING BAR	.472
PIN PLATE SHIM	.498
(A) SHIM	.018
INSERT	I0517
(B) ALTERNATE INSERT SET-UP	
PIN	3000-38
SPACER	0.250"
INSERT	HB-3816-2.50

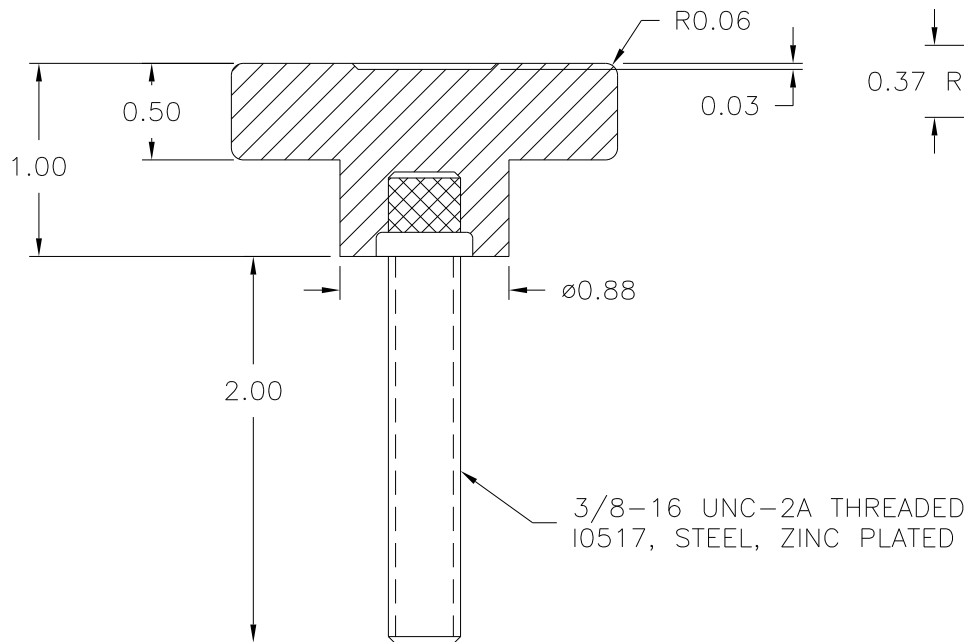
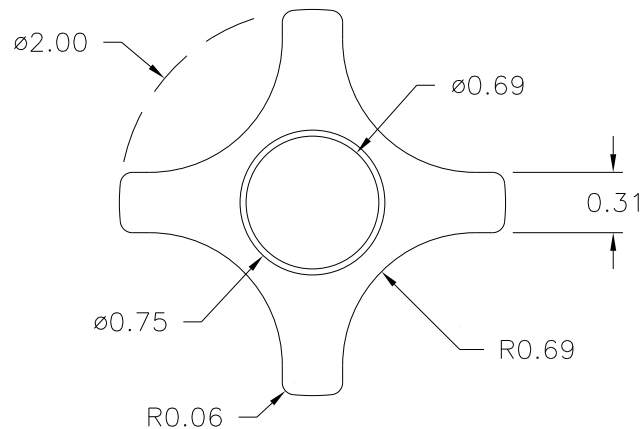

(B) ALTERNATE INSERT SET-UP

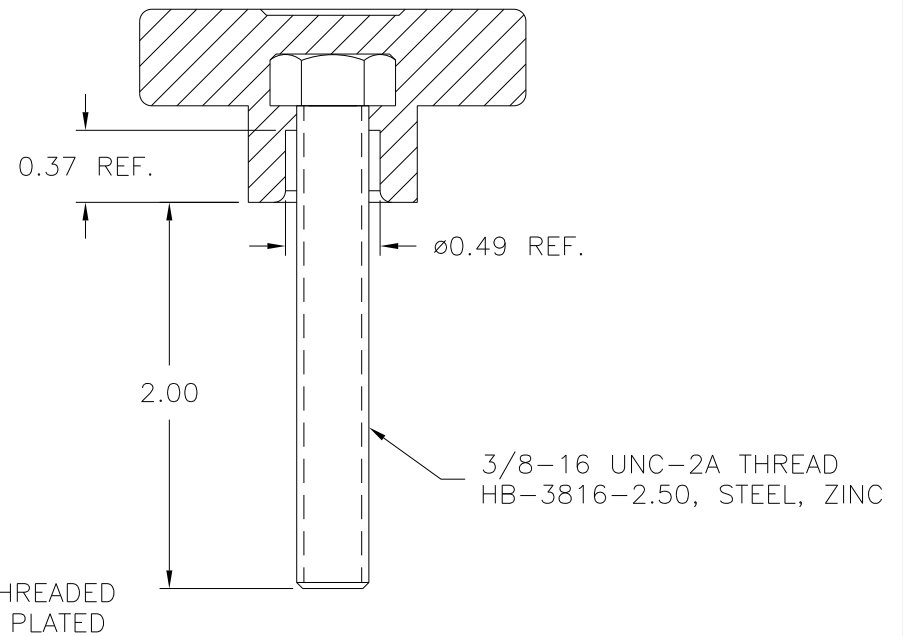

MATERIAL: #4311 PLENCO PHENOLIC (B41)
COLOR: BLACK

TOLERANCES: UNLESS OTHERWISE SPECIFIED	DO NOT SCALE DRAWING	B	ADDED ALT. INSERT	JAM	9/16/11
		A	SHIM WAS .078	ST	5/10/01
DECIMALS: X.XXX ± .005 X.XX ± .015	MM: X.XX ± 0.15MM X.X ± 0.4MM	-	RE-DID REDRAW	TL	11/19/99
		-	CAD REDRAW	HD	4/12/93
FRACTIONS ± 1/64	ANG. ± 1°	CHANGES			