



Chipsmall Limited consists of a professional team with an average of over 10 year of expertise in the distribution of electronic components. Based in Hongkong, we have already established firm and mutual-benefit business relationships with customers from,Europe,America and south Asia,supplying obsolete and hard-to-find components to meet their specific needs.

With the principle of “Quality Parts,Customers Priority,Honest Operation,and Considerate Service”,our business mainly focus on the distribution of electronic components. Line cards we deal with include Microchip,ALPS,ROHM,Xilinx,Pulse,ON,Everlight and Freescale. Main products comprise IC,Modules,Potentiometer,IC Socket,Relay,Connector.Our parts cover such applications as commercial,industrial, and automotives areas.

We are looking forward to setting up business relationship with you and hope to provide you with the best service and solution. Let us make a better world for our industry!



Contact us

Tel: +86-755-8981 8866 Fax: +86-755-8427 6832

Email & Skype: info@chipsmall.com Web: www.chipsmall.com

Address: A1208, Overseas Decoration Building, #122 Zhenhua RD., Futian, Shenzhen, China



DB-Expander Daughterboard-to-SIP (#28325)

General Description

The DB-Expander provides the means to use daughterboards, designed for Parallax's motherboards, with solderless breadboards and other Parallax products.

Features

- Plug-compatible with Parallax daughterboards.
- SIP header on 0.1" centers for easy interface to solderless breadboards.
- SIP pinout plug-compatible with various Parallax products.

Application Ideas

- Interface Daughterboards to the Board of Education.
- Connect a PropCAM-DB to the Propeller Demo Board.
- Experiment with the TCS230DB Color Sensor using the Professional Development Board.

What's Included

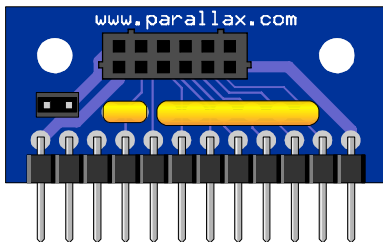

1 ea. DB-Expander board
with Vin jumper.

What You Need to Provide

- Parallax daughterboard.
- BOE, solderless breadboard, Propeller Demo Board, PropSTICK, or ... ?
- DB Extension cable, if you want the daughterboard at the end of a cable.

Daughterboard Connection

A Parallax daughterboard may be plugged directly into the DB-Expander. It will snap into place and, typically, require no further mechanical support. If you wish to add further support, however, the two mounting holes may be used with a pair of 5/16" long spacers or standoffs and #4 screws to attach the daughterboard more securely.

As an alternative, the daughterboard may be tethered to the DB-Expander at the end of a cable. The DB-Extension Cable (Stock #800-28301), with a plug at one end and a socket at the other, is perfect for this.

External Connections

The DB-Expander is labeled to identify the power and signal lines required for interfacing to a daughterboard, as shown below, and described further:

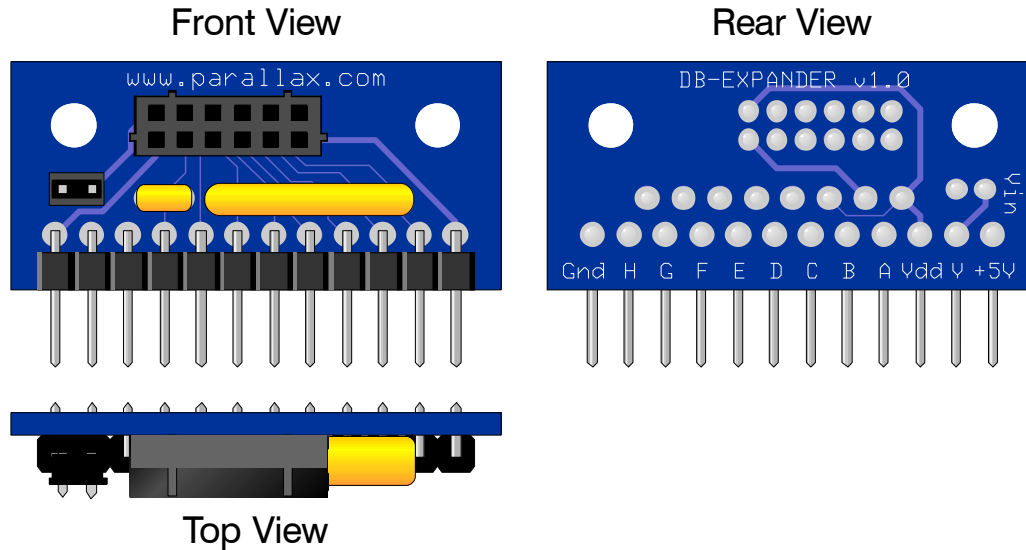

Ground

The pin labeled "Gnd" should be connected to your system ground.

Power

Every daughterboard will require a connection to Vdd, +5V, or both. Be sure you know what the daughterboard's Vdd requirements are before making this connection. Some can run at both 3.3V and 5V; others, just one or the other.

A few daughterboards may also require a connection to an unregulated Vin supply. By installing the included jumper on the Vin header, any voltage applied to the DB-Expander pin labeled "V" will be applied to the daughterboard's Vin pin.

Daughterboard Signal Lines

The signal lines to the daughtercard are labeled **A** through **H**. Lines **E**, **F**, **G**, and **H** are pulled up to Vdd via 4.7K resistors, as their equivalents are on the Parallax motherboards. This is done to accommodate I2C devices on **E** and **F**, as well as other open-collector/open-drain devices that may be used on **G** and **H**. However, no series resistors are provided on any of the signal lines. If you need this added protection in your circuitry, add 330 ohm resistors in series with those signal lines needing the extra protection.

The signal line connections and their meanings will depend on which daughterboard is plugged into the DB-Expander. These are shown in the table on the following page.

Daughterboard	Vdd	+5V	Vin	A	B	C	D	E	F	G	H
TCS230-DB	3.3V/5V	5V	None	S0	S1	OUT	LED	S2/ID	S3	None	None
PWR-I/O-DB	None	5V or None	Vin or None	A0	A1	A2	A3	P9	P8	None	None
Proto-DB	User spec	User spec	User spec	A	B	C	D	E	F	G	H
PropCAM-DB	3.3V	5V	None	D0	D1	D2	D3	SCL	SDA	VSYNC	CLK

Connection with Various Parallax Products

The following sections show how the DB-Expander may be used with various different Parallax products.

Board of Education and BOE-Bot

The Board of Education has a solderless breadboard that the DB-Expander can readily plug into. The illustration below shows one such application. In this app, both Vdd and +5V are connected to the BOE's Vdd (i.e. 5V), and Vin is connected to the BOE's Vin line:

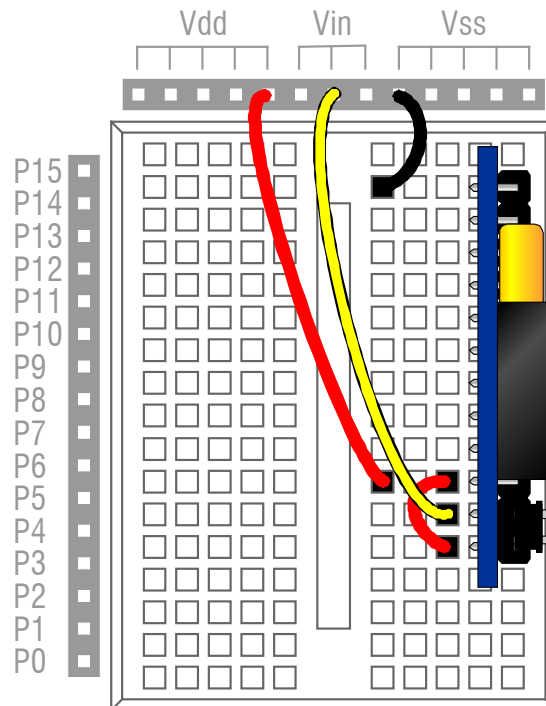

Daughterboards that need a Vdd of 3.3V will require a user-provided 3.3V regulator and a way to interface the BASIC Stamp's 5V signal lines.

AppMod Connector

In a few applications, it may be possible to plug the DB-Expander directly into an AppMod socket. The illustration below shows how it's done:

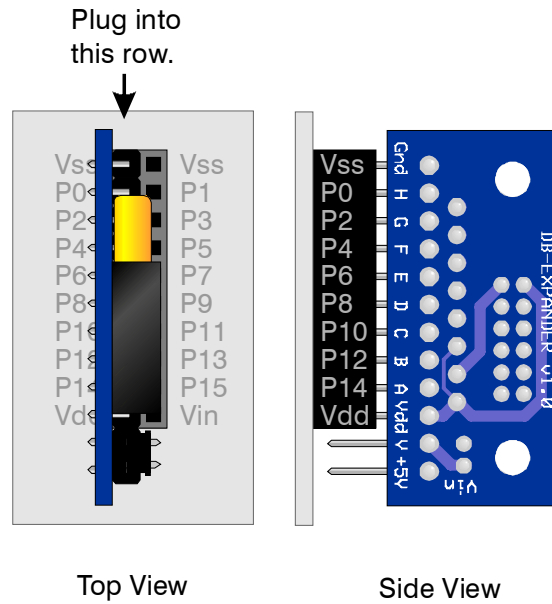

In this circumstance, neither Vin nor +5V can be connected to the daughterboard handily. Also, every other BASIC Stamp port (i.e. the even-numbered ones) is used, which may not be optimum. But in cases where this will work, it makes an easy daughterboard interface.

Propeller Demo Board

The DB-Expander can plug directly into the Propeller Demo Board's power and signal header, as shown below:

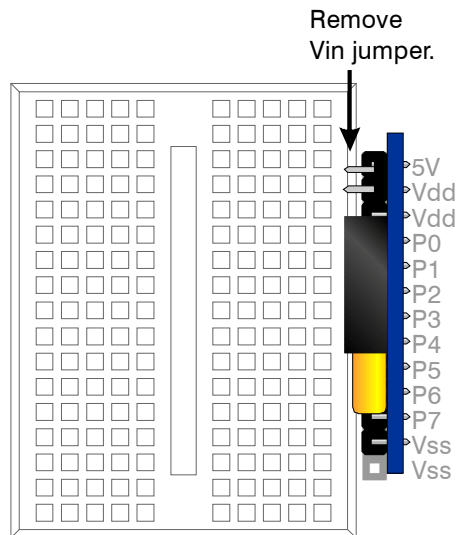

It is important to remove the Vin jumper from the DB-Expander board, unless you want your daughterboard's Vin pin to be powered by +5V.

PropSTICK

The DB-Expander is compatible with both the PropSTICK Kit and the PropSTICK USB. The illustration below shows it installed with the PropSTICK Kit. Use with the PropSTICK USB will be similar.

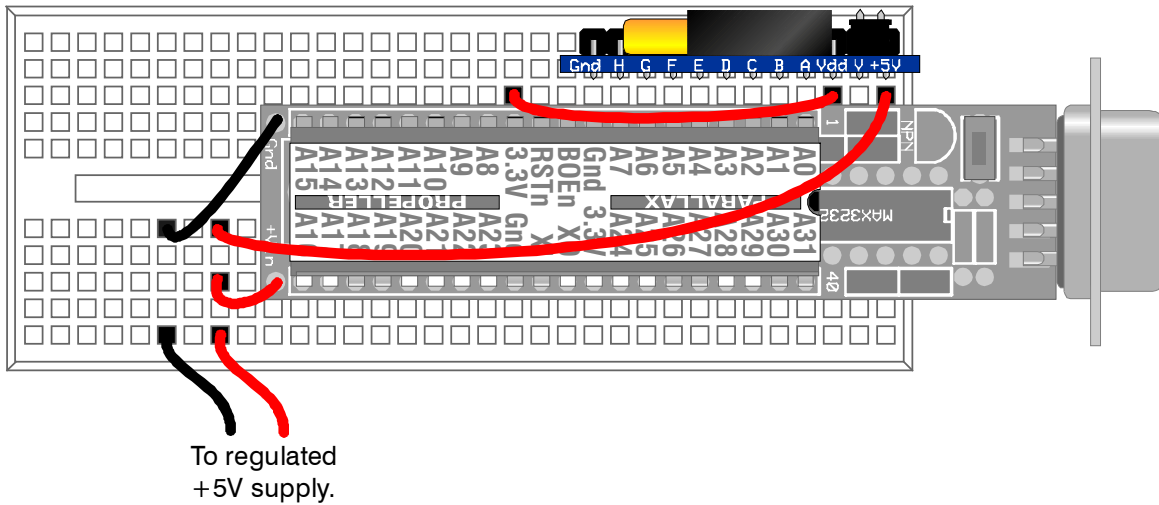

In this example, V_{in} is not connected. If the daughterboard requires it, an unregulated 6-9V supply could be connected to "V".

Schematic

