



Chipsmall Limited consists of a professional team with an average of over 10 year of expertise in the distribution of electronic components. Based in Hongkong, we have already established firm and mutual-benefit business relationships with customers from,Europe,America and south Asia,supplying obsolete and hard-to-find components to meet their specific needs.

With the principle of "Quality Parts,Customers Priority,Honest Operation,and Considerate Service",our business mainly focus on the distribution of electronic components. Line cards we deal with include Microchip,ALPS,ROHM,Xilinx,Pulse,ON,Everlight and Freescale. Main products comprise IC,Modules,Potentiometer,IC Socket,Relay,Connector.Our parts cover such applications as commercial,industrial, and automotives areas.

We are looking forward to setting up business relationship with you and hope to provide you with the best service and solution. Let us make a better world for our industry!



Contact us

Tel: +86-755-8981 8866 Fax: +86-755-8427 6832

Email & Skype: info@chipsmall.com Web: www.chipsmall.com

Address: A1208, Overseas Decoration Building, #122 Zhenhua RD., Futian, Shenzhen, China



THIS DRAWING IS UNPUBLISHED.

RELEASED FOR PUBLICATION

20

© COPYRIGHT 20 BY -

ALL RIGHTS RESERVED.

REVISIONS

P	LTR	DESCRIPTION	DATE	DWN	APVD
	A	INITIAL RELEASE	6JUN2016	Z.W	X.X

DATE CODE
 YY WW X
 ↑ ↑ ↑
 YY=YEAR
 EX: 16=2016
 WW=WEEK
 EX: 12=12
 X=DAY
 EX: 5=5

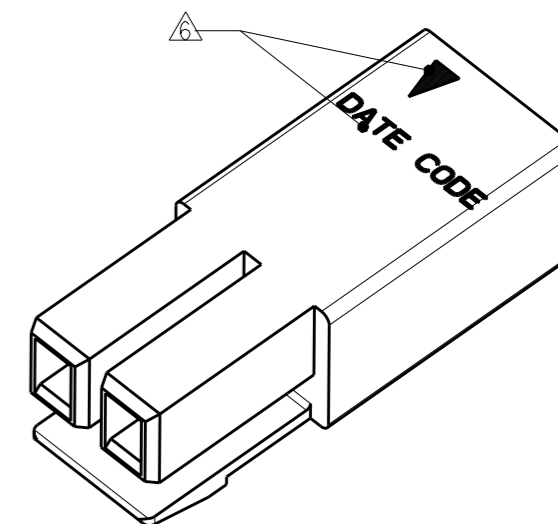
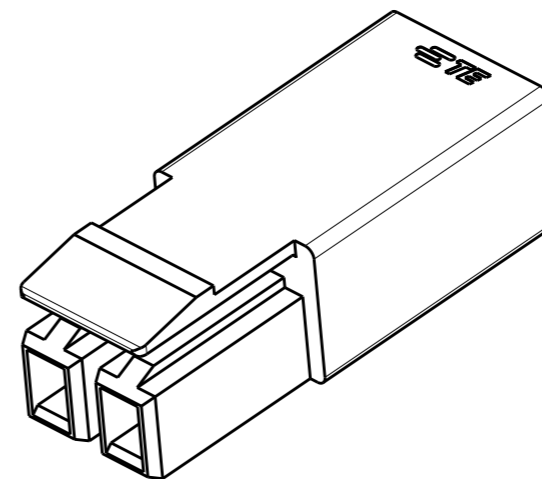
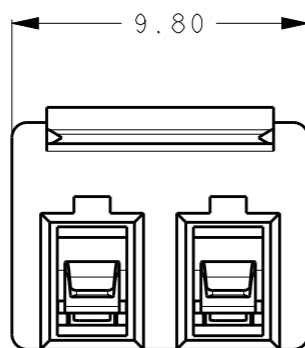
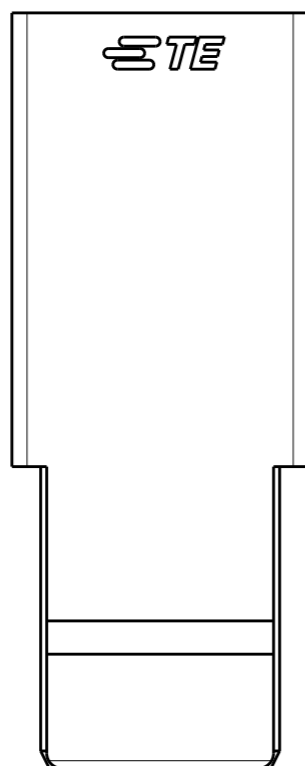

NOTE:

- PART NUMBER: SEE TABLE.
 - MATERIAL:
TERMINAL: COPPER ALLOY
HOUSING: THERMOPLASTIC, UL94-V0.
 - FINISH
TERMINAL: TIN PLATING OVERALL.
 - PACKAGING: PLASTIC BAG.
 - APPLICABLE WIRE:
SOLID: 18-22AWG.
STRANDED WIRE: 16-20 AWG(26 STRANDS MAX. FOR 16 AWG
16 STRANDS MAX. FOR 18AWG, 7 STRANDS MAX. FOR 20AWG.
(14AWG: 7 STRANDS, 16 AWG: 26 STRANDS, 18AWG:16STRANDS)
- △ MARK APPROXIMATION LOCATION.

AS SHOWN: 2834048-1/2/3/4

2834048-4	2834049-4	RED
2834048-3	2834049-3	ORANGE
2834048-2	2834049-2	BLACK
2834048-1	2834049-1	NATURAL
PART NUMBER	MATING SIDE P/N	PART COLOR

THIS DRAWING IS A CONTROLLED DOCUMENT.		DWN ZHANG WEI 18DEC2015	TE Connectivity	
DIMENSIONS: mm		CHK SHI MING 18DEC2015		
		APVD XU XIANG 18DEC2015	NAME 2 PIN LATCHED WIRE TO WIRE CONNECTOR PLUG ASSEMBLY	
TOLERANCES UNLESS OTHERWISE SPECIFIED: ±0.5		PRODUCT SPEC	-	
0-PLC ±		APPLICATION SPEC	-	
1-PLC ±		WEIGHT	-	
2-PLC ±		CUSTOMER DRAWING	-	
3-PLC ±		SCALE	3:1	
4-PLC ±		SHEET	1 OF 2	
ANGLES ±1°		DRAWING NO	A300779C-2834048	
FINISH		RESTRICTED TO	-	
-		REV	A	
-				

THIS DRAWING IS UNPUBLISHED.

RELEASED FOR PUBLICATION

20

© COPYRIGHT 20 BY -

ALL RIGHTS RESERVED.

REVISIONS

P	LTR	DESCRIPTION	DATE	DWN	APVD
-		SEE SHEET 1	-	-	-

NOTE:
1. PACKAGING QUANTITY: SEE TABLE.

PAIRS PER BAG	BAGS PER CARTON	PAIRS PER CARTON
500	8	4000

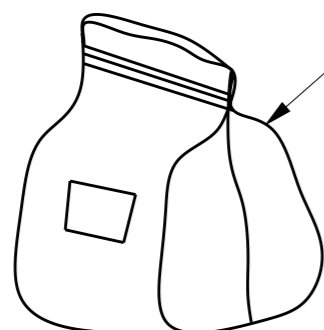
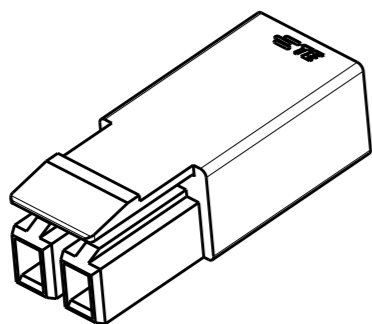

PLASTIC BAG

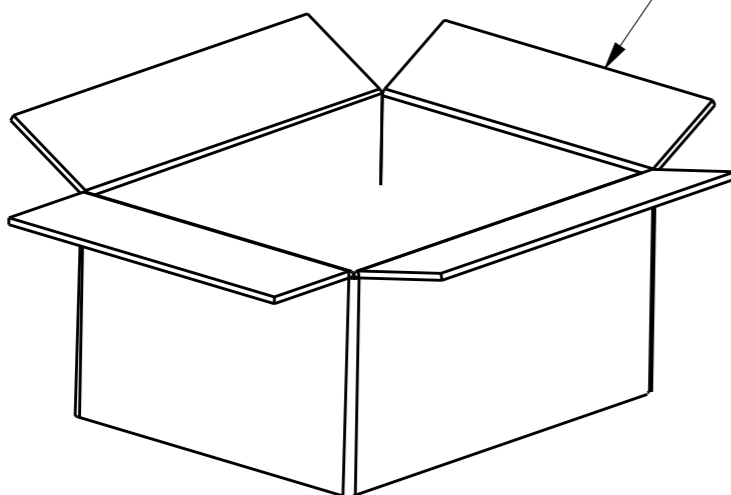

CARTON

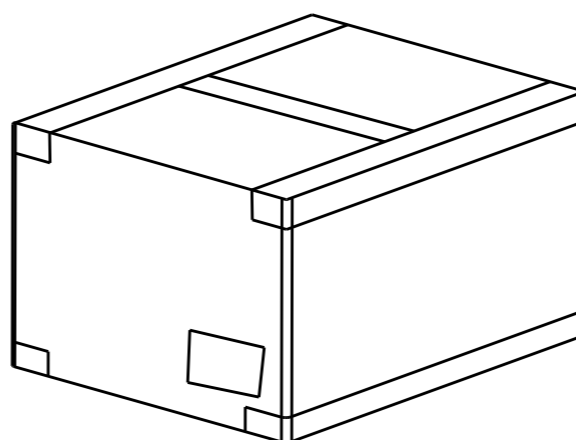

THIS DRAWING IS A CONTROLLED DOCUMENT.

DIMENSIONS:	TOLERANCES UNLESS OTHERWISE SPECIFIED:
mm	
	0 PLC ±
	1 PLC ±
	2 PLC ±
	3 PLC ±
	4 PLC ±
	ANGLES ±1°
MATERIAL	FINISH
-	-
-	-

DWN	ZHANG WEI	18DEC2015
CHK	SHI MING	18DEC2015
APVD	XU XIANG	18DEC2015
PRODUCT SPEC	-	
APPLICATION SPEC	-	
WEIGHT	-	
CUSTOMER DRAWING		



NAME
2 PIN LATCHED WIRE TO WIRE CONNECTOR
PLUG ASSEMBLY

SIZE	CAGE CODE	DRAWING NO	RESTRICTED TO
A3	00779	C=2834048	-
SCALE 3:1		SHEET 2 OF 2	REV A