



Chipsmall Limited consists of a professional team with an average of over 10 year of expertise in the distribution of electronic components. Based in Hongkong, we have already established firm and mutual-benefit business relationships with customers from,Europe,America and south Asia,supplying obsolete and hard-to-find components to meet their specific needs.

With the principle of “Quality Parts,Customers Priority,Honest Operation,and Considerate Service”,our business mainly focus on the distribution of electronic components. Line cards we deal with include Microchip,ALPS,ROHM,Xilinx,Pulse,ON,Everlight and Freescale. Main products comprise IC,Modules,Potentiometer,IC Socket,Relay,Connector.Our parts cover such applications as commercial,industrial, and automotives areas.

We are looking forward to setting up business relationship with you and hope to provide you with the best service and solution. Let us make a better world for our industry!



Contact us

Tel: +86-755-8981 8866 Fax: +86-755-8427 6832

Email & Skype: info@chipsmall.com Web: www.chipsmall.com

Address: A1208, Overseas Decoration Building, #122 Zhenhua RD., Futian, Shenzhen, China



PI-EX-MB/16/3/D-SUB



**Ex Universal Module Carrier (Motherboard)
for Accommodating 3-Wire Measuring Transducers,
Intrinsically Safe, for a Maximum of 16 PI Ex Modules**

INTERFACE

Data Sheet
103031_00_en

© PHOENIX CONTACT - 05/2007

1 Description

The **PI-EX-MB/16/3/D-SUB** Ex universal module carrier (motherboard) is used as the base element for 16 plug-in PI Ex modules. This is an item of associated equipment from Phoenix Contact for use in potentially explosive areas according to Ex-i protection.

The Ex universal module carrier can be snapped onto popular DIN rails (e.g., NS 35/7.5 or NS 32).

It has 16 electronics bases for accommodating and contacting plug-in PI Ex special function modules, which are grouped together on the motherboard in a stable housing.

Each of the 16 slots for the PI Ex modules has three terminal points to field level, to which 3-wire measuring transducers can be connected. A 37-pos. D-SUB connector is installed on the system side.

The power is supplied centrally. On the system side, a multiple connector enables all modules to be connected directly to the I/O module.

Here, the signals are routed 1:1 to the D-SUB connector, whereby the system cable is used to adapt to the relevant I/O modules.

1.1 Properties

- 16-channel
- Compact, mechanically stable design
- Can be mounted on EN DIN rails
- Ex-i version
- Redundant diode-isolated supply
- Fuse monitoring via LED and relay contact (PDT)
- Error message in the event of fuse failure
- Protection against polarity reversal



The device is an associated item of equipment and must not be installed in potentially explosive areas. When installing and operating the device, the applicable safety directives (including national safety directives), accident prevention regulations, as well as general technical regulations, must be observed.



Observe the safety regulations and installation notes on page 4.



Make sure you always use the latest documentation.
It can be downloaded at www.download.phoenixcontact.com.
A conversion table is available on the Internet at
www.download.phoenixcontact.com/general/7000_en_00.pdf.



This data sheet is valid for all products listed on the following page:

Table of Contents

1	Description.....	1
2	Ordering Data.....	2
3	Technical Data.....	2
4	Safety Regulations and Installation Notes.....	4
5	Structure.....	5
6	Installation.....	5
7	Pin Assignment.....	6

2 Ordering Data

Ex Universal Module Carrier

Description	Type	Order No.	Pcs./Pck.
Ex universal module carrier for accommodating 3-wire measuring transducers, for a maximum of 16 PI Ex modules, intrinsically safe	PI-EX-MB/16/3/D-SUB	2835587	1

Jumpers

Description	Type	Order No.	Pcs./Pck.
Wire jumper, 50-pos., can be separated, for jumpering identical inputs and outputs, 0.5 mm ² , insulation:			
Black	DB 50- 90 BK	2820916	1
Blue	DB 50- 90 BU	2821180	1
Gray	DB 50- 90 GY	2820929	1



For additional accessories, please refer to the "INTERFACE" catalog from Phoenix Contact.

3 Technical Data

Connection Data

Connection to system level	37-pos. D-SUB male connector (DIN 41652/IEC 60807-2) Maximum permissible current = 1 A (125 V AC/DC) Rated surge voltage: 1.5 kV
Connection to field level	16 PCB screw termination blocks (3-pos.)
Stripping length	8 mm
Thread	M5
Tightening torque	0.5 Nm, minimum/0.6 Nm, maximum
Conductor cross-section (system and field level)	
Solid (minimum/maximum)	0.2 mm ² /4 mm ²
Stranded (minimum/maximum)	0.2 mm ² /2.5 mm ²
AWG (minimum/maximum)	24/12

General Data

Power supply	Redundant, diode-isolated
Nominal voltage	20 V DC ... 35 V DC
Protection against polarity reversal	Yes
Operating voltage monitoring	If one of the two supplies fails, the corresponding green LED switches off and the relay contact opens/closes.
Safety monitoring	In the event of fuse failure, the relay contact opens/closes.
Load capacity of the alarm contact	
Switching power	1250 VA, maximum
Switching current	5 A, maximum
Switching voltage	250 V, maximum
Housing insulation material	Polyamide PA non-reinforced, polycarbonate PC, PVC

General Data (Continued)

Color	Green
Degree of protection	IP20
Width x length x height (height with NS 32, NS 35/7,5, NS 35/15 coupling connector)	247.7 mm x 127.5 mm x 82.6 mm (147.5 mm, 142.5 mm, 150 mm)
Inflammability class according to UL 94	V0/V2
Air and creepage distances	IEC 60664, DIN VDE 0110, EN 50020

Ambient Conditions

Ambient temperature range	-20°C ... +60°C
Permissible humidity (operation and storage/transport)	10% ... 95% (relative humidity, no condensation)
Vibration	2g (according to DIN EN 60068-2-26)
Shock	15g (according to DIN EN 60068-2-27)
Height (installation location)	2000 m above sea level, maximum
Height (storage location)	3500 m above sea level, maximum

Safety Data

Maximum voltage [*] U _m	250 V
For PI Ex special function modules with U _{0 max}	30 V

^{*} The maximum voltage that can be applied to non-intrinsically safe connection parts of associated equipment without affecting the intrinsic safety.

Approvals

CE	Yes
ATEX	⊕ II (1) GD [EEx ia] IIC, KEMA 99 ATEX 7296

4 Safety Regulations and Installation Notes

4.1 General

Installation and Operation



The device is an associated item of equipment and must not be installed in potentially explosive areas.



Installation, operation, and maintenance may only be carried out by qualified personnel.

When installing and operating the device, the applicable safety directives (including national safety directives), accident prevention regulations, as well as general technical regulations, must be observed.

The safety data and features provided according to the valid EC-type examination (or other approvals, if necessary) are listed in the technical data.



Install the device according to the instructions in the operating instructions.

The circuits inside the device must not be accessed.

Do not repair the device yourself, replace it with an equivalent device. Repairs may only be carried out by the manufacturer.



The device must not be subject to mechanical strain and/or thermal loads, which exceed the limits described in these operating instructions.



The IP20 **degree of protection** of the device is intended for use in a clean and dry environment. IP54 protection must otherwise be provided.

In order to provide protection against mechanical or electrical damage, install the device in corresponding housing with a suitable degree of protection according to IEC 60529.

Where dust is present, install the device in suitable housing with at least IP5x protection.

4.2 Use in Potentially Explosive Areas



Observe the specified conditions for use in potentially explosive areas.

ATEX



Connection to the **intrinsically safe circuit in areas with a danger of dust explosions** (Zone 20, 21 or 22) is only permitted if the equipment connected to this circuit is approved for this zone (e.g., Category 1D, 2D or 3D).

Intrinsically Safe Circuits



When carrying out **measurements on the intrinsically safe side**, observe the relevant regulations regarding the connection of intrinsically safe equipment.

Only use intrinsically safe circuits for these approved devices.



If the device has been used in non-intrinsically safe circuits, it must not be used again in intrinsically safe circuits.

The module must be clearly labeled as non-intrinsically safe.

5 Structure

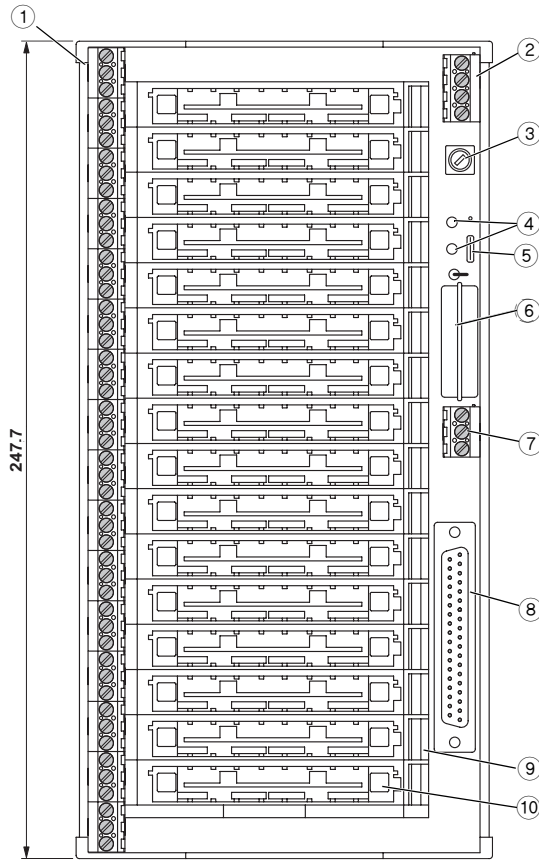
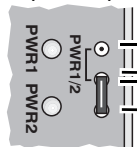

Figure 1 Structure

- 1 16 terminal block bases, channel 1 - 16 for field signals (Ex area); each channel has three terminal points ("1", "2", "3")
- 2 Terminal block base for redundant power supply (PWR1: "+", "-"; PWR2: "+", "-")
- 3 Fuse
- 4 Two LEDs for PWR1 and PWR2
- 5 Jumper for power supply



b Position b: Non-redundant
a Position a: Redundant

- 6 PDT relay (plug-in)
- 7 Alarm contact for voltage monitoring
- 8 37-pos. D-SUB connector (to process control system/to PLC)
- 9 Labeling field
- ⑩ Holder for keying pin

Dimensions

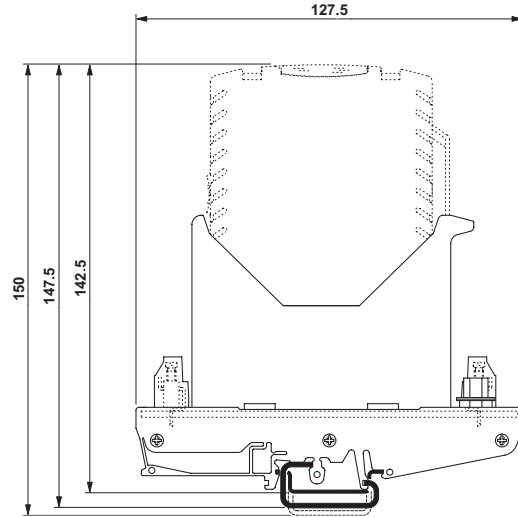

Figure 2 Dimensions (in mm)

6 Installation



Electrostatic discharge

The device contains components that can be damaged or destroyed by electrostatic discharge. When handling the device, observe the necessary safety precautions against electrostatic discharge (ESD), according to EN 61340-5-1 and EN 61340-5-2, as well as IEC 61340-5-1 and IEC 61340-5-2.

6.1 Wiring of the Universal Module Carrier

The PI-EX-MB/16/3/D-SUB universal module carrier can be snapped onto various popular DIN rails.

On the field side (intrinsically safe side), the intrinsically safe signal cables are connected to the terminal points marked "1", "2", and "3" of the relevant channel. These 3-pos. terminal block bases are numbered 1 to 16 to correspond to the channel number.

On the system side, the signal cables are connected to the 37-pos. D-SUB connector installed on the module carrier according to the connection scheme (see "Circuit diagram" on page 6).

The power is supplied centrally. It can be redundant at the PWR1 and PWR2 terminal points of the terminal block base and is diode-isolated. The green PWR1 and PWR2 LEDs indicate that the supply voltage is present.

If the power supply is to be non-redundant, the jumper must be set to PWR 1/2 "position b". Otherwise, the relay would drop out and thus indicate the failure of one of the two power supplies.

The operating voltage and the fuse are monitored by a relay with PDT contact. The relay is usually picked up. If it is to be operated as an N/C contact, the signal lines must be connected to terminal points "11" and "12" of the alarm contact. If it is to be operated as an N/O contact, the signal lines must be connected to terminal points "11" and "14" of the alarm contact.

6.2 Automatic Keying of the Electronic Connectors

The module carrier is not keyed by default upon delivery. The user-friendly keying is located in the electronic connector and consists of four plastic parts, which are joined together. When the module is first removed, the lower part of the keying pins remain in the module carrier. In this way, it is automatically keyed to the relevant electronic connector.

If a module is accidentally inserted in the wrong place, any plastic parts remaining in the module carrier can be removed using a screwdriver.

7 Pin Assignment

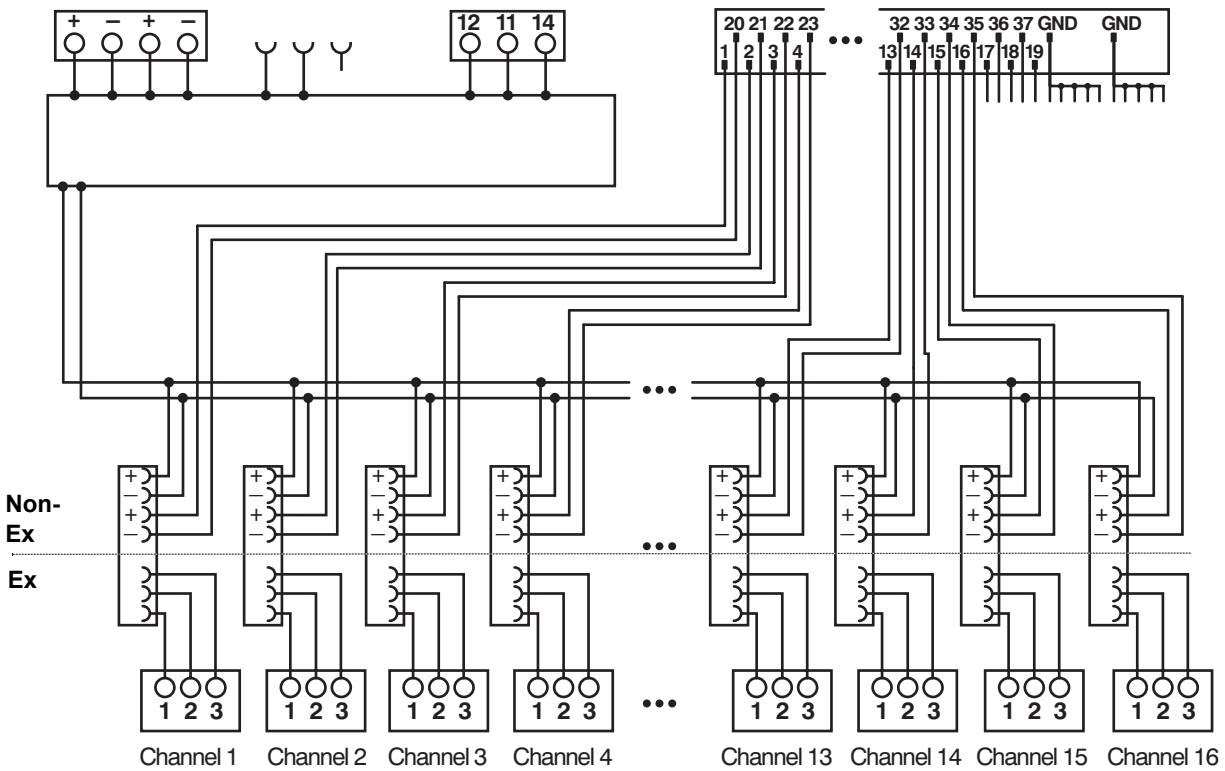

Figure 3 Circuit diagram

**7.1 Pin Assignment for PI-EX-RPSS-I/I
(Order No. 2835011)**

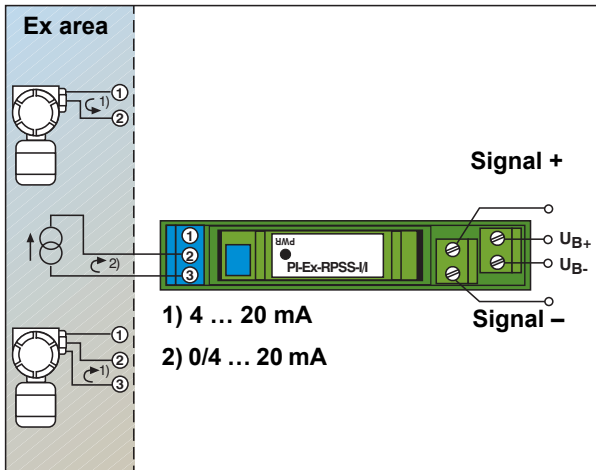

Figure 4 2-wire measuring transducer, analog signals supplied from the field side, and 3-wire measuring transducer

7.4 2-Pos. Pin Assignment

2-pos. pin assignment for:

- PI-Ex-NAM...
- PI-Ex-SD...
- PI-Ex-IDS-I/I
- PI-Ex-AIS-I/I

2-wire sensors are connected to terminal points 1 (+) and 2 (-) of blue COMBICON terminals.

© PHOENIX CONTACT 05/2007

**7.2 Pin Assignment for PI-EX-RTD-I
(Order No. 2835066)**

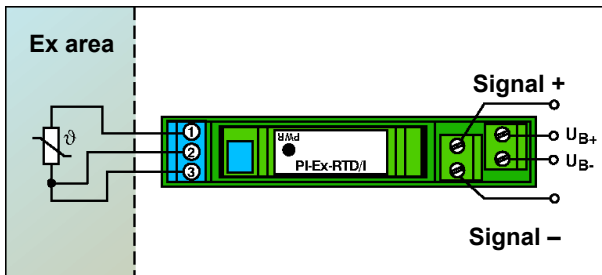

Figure 5 3-wire resistance thermometer

**7.3 Pin Assignment for PI-EX-DO/REL-S
(Order No. 2865120))**

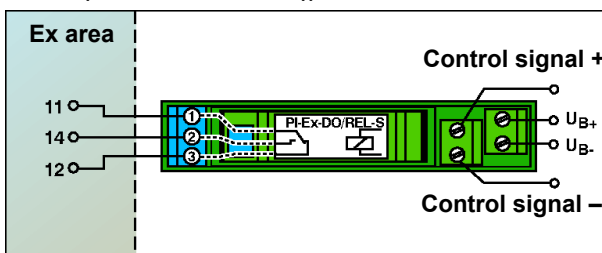

Figure 6 Full PDT function