



Chipsmall Limited consists of a professional team with an average of over 10 year of expertise in the distribution of electronic components. Based in Hongkong, we have already established firm and mutual-benefit business relationships with customers from,Europe,America and south Asia,supplying obsolete and hard-to-find components to meet their specific needs.

With the principle of “Quality Parts,Customers Priority,Honest Operation,and Considerate Service”,our business mainly focus on the distribution of electronic components. Line cards we deal with include Microchip,ALPS,ROHM,Xilinx,Pulse,ON,Everlight and Freescale. Main products comprise IC,Modules,Potentiometer,IC Socket,Relay,Connector.Our parts cover such applications as commercial,industrial, and automotives areas.

We are looking forward to setting up business relationship with you and hope to provide you with the best service and solution. Let us make a better world for our industry!



Contact us

Tel: +86-755-8981 8866 Fax: +86-755-8427 6832

Email & Skype: info@chipsmall.com Web: www.chipsmall.com

Address: A1208, Overseas Decoration Building, #122 Zhenhua RD., Futian, Shenzhen, China



IBS RL 24 DI 16/8-T

Digital Input Module with 16 Inputs

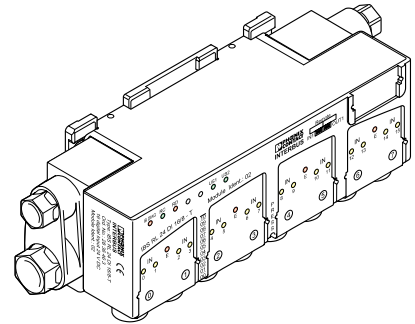

Data Sheet 5634B

04/2000

Product Description

The module is designed for use in systems engineering. With IP 67 protection, it is suitable for use without a control cabinet in harsh industrial conditions. It can, for example, be used on the tool platform, directly on welding robots, or in conveying systems.

Depending on the application area, this module allows you to connect the bus and the power supply to the module from two sides.

QUICKON bus connectors are used to feed the module with the power supply for the bus logic/sensors (24 V DC).

Features

- INTERBUS protocol (EN 50254)
- IP 67 protection
- Bus connection using copper cables
- QUICKON connectors for the supply voltage
- Sensors are connected using 5-pos. M12 female connectors
- Installation options:
 - directly to the welding robot
 - on aluminum mounting channels
 - two-position attachment
 - direct mounting

Note



This data sheet is intended to be used in conjunction with the Rugged Line I/O Systems Manual IBS RL SYS PRO UM E.



Note that the bus connectors and the mounting plate are not supplied as standard (see Ordering Data page 12).



Only connect and remove the bus connector when power has been disconnected. (Connection according to DIN EN 60204-1:1993-06.)



To ensure IP 67 protection you must note the following points:

- The bus connectors must be connected.
- You must not pierce the grommet of unused bus connectors. (You will, for example, have unused connections if the module is the last device in the bus system.)
- Cover unused M12 female connectors with protective caps.

Connector Pin Assignment

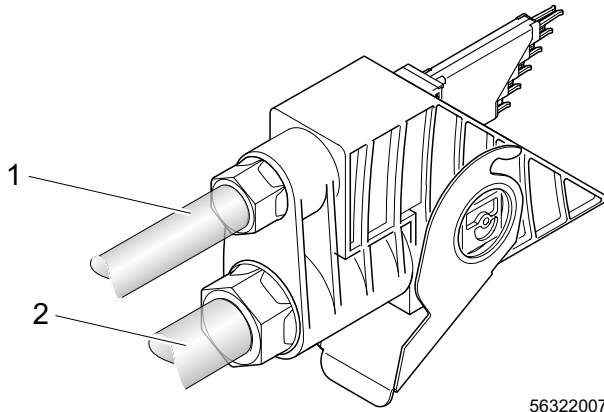

56322007

Figure 1 Connector pin assignment of the incoming or outgoing bus

- 1 INTERBUS remote bus
- 2 U_{S1}/U_{S2} power supply
 U_{S1} = bus/sensor supply
 U_{S2} = actuator supply



All U_{S1} and U_{S2} contacts are rated 16 A.

INTERBUS Remote Bus

Position in Figure 1	Signal	Connection Method	Wire Color	Designation
1	/DO	1	Green	GN
	DO	2	Yellow	YE
	/DI	3	Pink	PK
	DI	4	Gray	GY
	GND	5	Brown	BN

U_{S1}/U_{S2} Power Supply

Position in Figure 1	Signal	Connection Method	Wire Color	Des.
2	+24 V U_{S1}	1	Black	1
	GND U_{S1}	2	Black	2
	+24 V U_{S2}	3	Black	3
	GND U_{S2}	4	Black	4
	Functional earth ground	5	Yellow	5

Connecting the Inputs



Two inputs are assigned to each of the sockets 0 to 7.

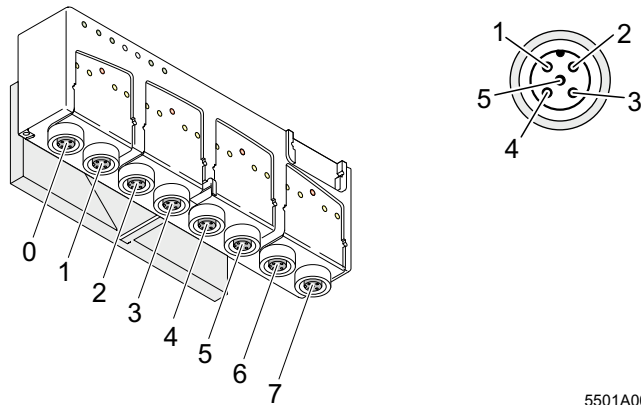

5501A005

Figure 2 Pin assignment of 5-pos. M12 sockets (1)

Pin	Socket 0	Socket 1	Socket 2	Socket 3	Socket 4	Socket 5	Socket 6	Socket 7
1	U _{S1} - 1 V (sensor supply)							
2	IN 1	IN 3	IN 5	IN 7	IN 9	IN 11	IN 13	IN 15
3	Ground U _{S1}							
4	IN 0	IN 2	IN 4	IN 6	IN 8	IN 10	IN 12	IN 14
5	Functional earth ground							

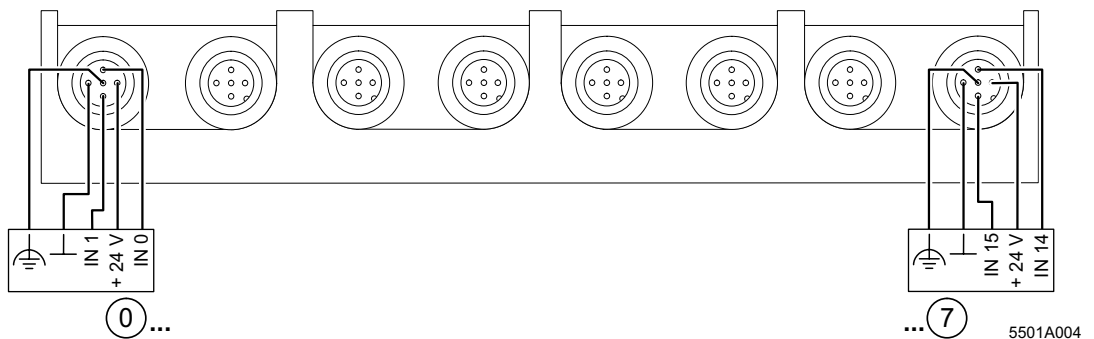

5501A004

Figure 3 Pin assignment of 5-pos. M12 sockets (2)

Electrical Isolation

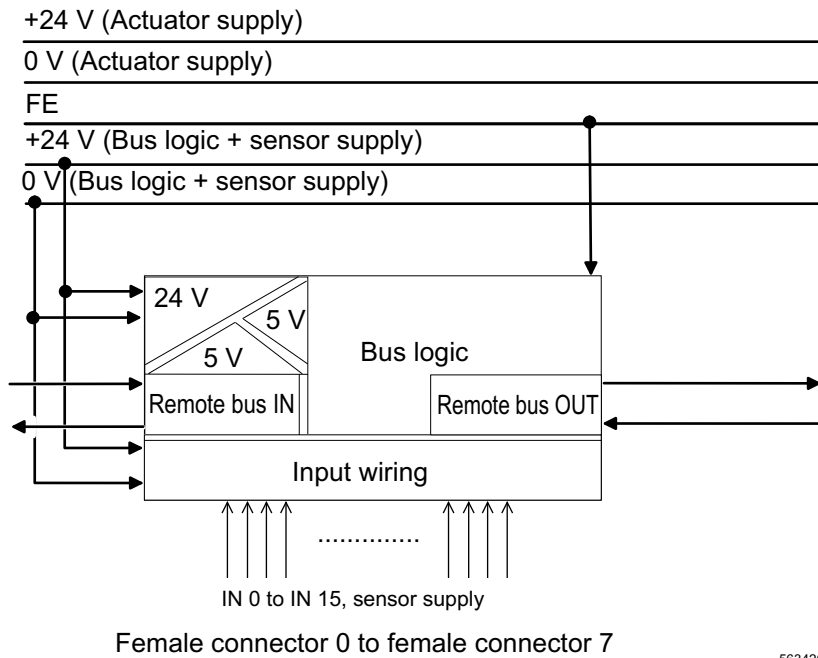

56342017

Figure 4 Block diagram

Programming Data

ID code	02 _{hex} (02 _{dec})
Length code	01 _{hex} (01 _{dec})
Input address area	2 bytes
Parameter channel (PCP)	Not present
Register length (bus)	2 bytes

Error Messages

- The breakdown of the sensor supply for a group of four inputs is indicated to the control or computer system (through the bus). The breakdown is stored in the module.
- The bus indicates to the control or computer system that the supply voltage U_{S1} has dropped below the permissible range.
- Upon delivery the module is set up so that errors concerning the supply voltage U_{S1} or the sensor supply are indicated via the bus. If the supply voltage U_{S2} is not present or is below the permissible voltage range this is not indicated but only displayed by the US2 LED.
- The error messages are reset through acknowledgment in the control or computer system.
- The configuration data and the error messages (except for undervoltage diagnostics) are only stored in the volatile memory of the module. Configuration data and error messages are deleted when the power is reset.

Assignment to the INTERBUS Input Data Word

(Byte.bit) view	Byte	Byte 0								Byte 1							
	Bit	7	6	5	4	3	2	1	0	7	6	5	4	3	2	1	0
Terminal	Slot	3	3	2	2	1	1	0	0	7	7	6	6	5	5	4	4
	Input	7	6	5	4	3	2	1	0	15	14	13	12	11	10	9	8
		Status input 0 to 7								Status input 8 to 15							



For the assignment of the illustrated (Byte.Bit) view for your control or computer system, please refer to data sheet DB GB IBS SYS ADDRESS, Part No. 90 00 99 0.

Status and Diagnostic Indicators

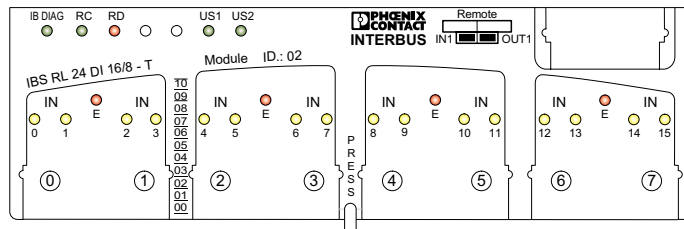

56342015

Figure 5 Positions of the status and diagnostic indicators

IB DIAG	Green LED	INTERBUS diagnostics
	OFF:	Supply voltage not present
	Flashing at 0.5 Hz:	Supply voltage present, bus not active
	Flashing at 2 Hz:	Supply voltage present, I/O error
RC	Green LED	Remote bus cable check
	ON:	Incoming remote bus connection established
	OFF:	Incoming remote bus connection defective
RD	Red LED	Remote bus status (Remote Bus Disabled)
	ON:	Outgoing remote bus switched off
US1	Green LED	Monitoring the supply voltage U_{S1}
	OFF:	U_{S1} not present
	Flashing:	U_{S1} below the permissible voltage range
	ON:	U_{S1} present
US2	Green LED	Monitoring the supply voltage U_{S2}
	Flashing:	U_{S2} below the permissible voltage range / not present
	ON:	U_{S2} present
E	Red LED	Error message
	ON:	Short-circuit of the sensor supply for a group of 4 inputs (This error message is stored temporarily on the module. It is stored in volatile memory and will be lost after power is reset.)
IN 0 - 15	Yellow LED	Status per input
	ON:	Input at logic 1
	OFF:	Input at logic 0

Housing dimensions

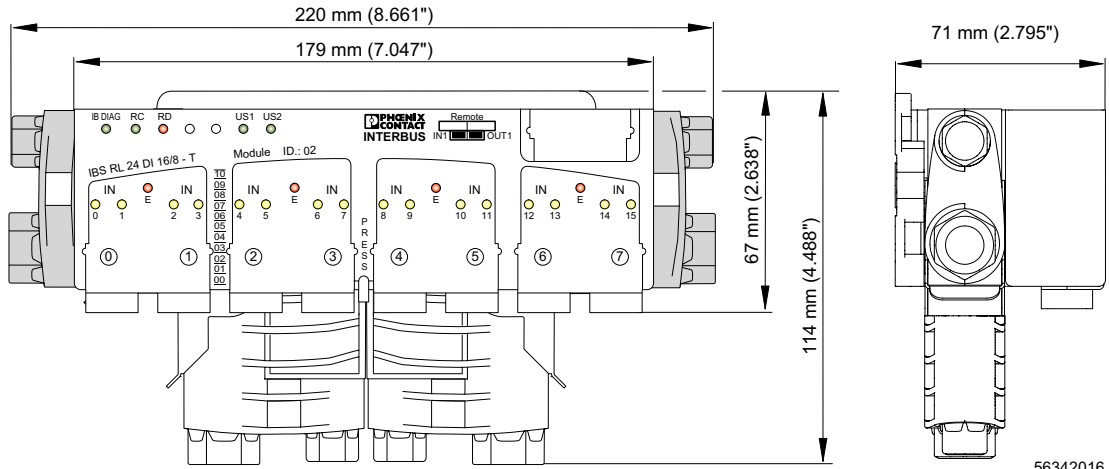



56342016

Figure 6 Housing Dimensions

Technical Data

General Data	
Ambient temperature	Operation: 0°C to +55°C (32°F to 131°F) Storage/transport: -25°C to +70°C (-13°F to 158°F)
Humidity	Operation: 100% Storage/transport: 95%, no condensation
Air pressure	Operation: 860 hPa to 1080 hPa (up to 1500 m [4921.260 ft.] above sea level) Storage/transport: 660 hPa to 1080 hPa (up to 3500 m [11,482.940 ft.] above sea level)
Degree of protection	IP 67 (when installed) Seal unused slots/connections to ensure IP 67 protection.
Material	Zinc die-cast Copper and nickel-plated surface
Electrical isolation between bus logic and I/O devices,	Test voltage 500 V AC, 50 Hz, 1 min
Housing dimensions (width x height x depth)	220 mm x 114 mm x 71 mm (8.661 in. x 4.488 in. x 2.795 in.) (with bus connector and mounting plate)
Weight	Approximately 720 g (without connector and mounting plate)

Supply Voltage U_{S1} (Bus Logic)	
Nominal voltage	24 V DC
Permissible range	18.5 V DC to 32 V DC (ripple included)
Ripple	3.6 V _{pp}
Current consumption	120 mA, typical, plus supply current for the sensors
Overvoltage protection	35 V (0.5 s)
Protection against polarity reversal	Yes (diode connected in parallel) 20 A, typical 500 ms

Supply Voltage U_{S1} (Bus Logic) (Continued)	
External fuse	5 A slow-blow, maximum
 Protection against polarity reversal is only effective if the module is externally protected. The power supply unit must be able to supply at least four times the rating of the external fuse.	
 The voltage U_{S1} is looped through and can be tapped off at the connector for the outgoing remote bus. The maximum continuous current must not exceed 16 A.	

Supply Voltage U_{S1} (Sensor Voltage)	
 The sensors are supplied in groups of four via a short-circuit-proof sensor supply.	
Nominal voltage	U_{S1} minus 1 V
Current consumption	800 mA total current for all inputs (50 mA per input)
Protection	Electronic overload/short-circuit protection per group

Supply Voltage U_{S2} (Actuator Voltage)	
Protection against polarity reversal	Yes (diode connected in series)
 The voltage U_{S2} is looped through and can be tapped off at the connector for the outgoing remote bus. The maximum continuous current must not exceed 16 A.	

INTERBUS Interface	
Interface type	2-wire installation remote bus Differential signal lines, twisted in pairs
Connection method	IP 67 connector

Digital Inputs	
Number of inputs	16
Electrical isolation between I/O devices and bus logic	Test voltage 500 V AC, 50 Hz, 1 min
Input voltage	DIN EN 6113-2: Permissible range 0 signal: 0 V to +5 V Permissible range 1 signal: 11 V to 30 V
Input current	3 mA, typical

Digital Inputs	
Permissible residual current, "0" Signal	1.5 mA, typical
Delay time 0 → 1	3 ms, typical
Delay time 1 → 0	3 ms, typical

Characteristic of the Inputs	
Input Voltage (V)	Input Current (mA), typical
$0 < U_{IN} < 0.7$	0
3	0.23
6	0.51
9	0.92
12	1.37
15	1.80
18	2.25
21	2.68
24	3.13
27	3.57
30	4.01

Typical Switching Threshold of the Inputs		
Signal Transition	Input Voltage (V)	Input current (mA), typical
0 → 1	7.52	0.72
1 → 0	7.49	0.72

Ordering Data

Description	Order Designation	Order No.
Digital input module	IBS RL 24 DI 16/8-T	28 36 46 3
Bus connector (2 pcs. needed)	IBS RL PLUG-T	27 31 89 8
Mounting plate	IBS RL AP	27 31 12 8
Labeling fields (set of 50 pcs.)	IBS RL MARKER-SET	27 32 72 9
Protective caps (5 pcs.) for unused M12 sockets	IBS IP PROT IO	27 59 91 9
Rugged Line I/O Systems Manual	IBS RL SYS PRO UM E	27 43 78 9
Remote bus cable for very flexible applications, welding-splash-resistant in standard applications	IBS RBC METER/F-T	27 23 12 3
Supply cable, 5 x 1.5 mm ² (16 AWG), gray, very flexible, welding-splash-resistant in standard applications	IBS PWR/5 HD/F	28 36 15 9
Supply cable, 5 x 1.5 mm ² (16 AWG)	IBS PWR/5	28 20 00 0
Fiber cutter	IBS RL FOC	27 25 14 7

© Phoenix Contact 04/2000 Subject to technical modification TNR 94 23 47 1