



Chipsmall Limited consists of a professional team with an average of over 10 year of expertise in the distribution of electronic components. Based in Hongkong, we have already established firm and mutual-benefit business relationships with customers from,Europe,America and south Asia,supplying obsolete and hard-to-find components to meet their specific needs.

With the principle of “Quality Parts,Customers Priority,Honest Operation,and Considerate Service”,our business mainly focus on the distribution of electronic components. Line cards we deal with include Microchip,ALPS,ROHM,Xilinx,Pulse,ON,Everlight and Freescale. Main products comprise IC,Modules,Potentiometer,IC Socket,Relay,Connector.Our parts cover such applications as commercial,industrial, and automotives areas.

We are looking forward to setting up business relationship with you and hope to provide you with the best service and solution. Let us make a better world for our industry!



Contact us

Tel: +86-755-8981 8866 Fax: +86-755-8427 6832

Email & Skype: info@chipsmall.com Web: www.chipsmall.com

Address: A1208, Overseas Decoration Building, #122 Zhenhua RD., Futian, Shenzhen, China



PART NAME: KNOB

SCALE: 1:1

DATE: 12/12/95

DR. BY HD



DESIGNERS & MANUFACTURERS OF KNOBS, HANDLES, CASES & CUSTOM PLASTIC COMPONENTS

P/N 2837-L

THIS DRAWING IS THE PROPERTY OF DAVIES MOLDING COMPANY. IS SUBMITTED SOLELY AS A DESIGN OR ENGINEERING PROJECT. WE ACCEPT NO RESPONSIBILITY WHATSOEVER FOR THE PRACTICAL APPLICATION OF THE PIECES MADE TO THIS DESIGN.

DO NOT SCALE DRAWING

MNO. 73

CAVITY	2837
CAVITY PLUG	2837
CORE	2837
SLEEVE	M-2837
PIN	2837-C
INSERT	I0854

ALTERNATE TOOL SET-UP

PIN	2837-L
INSERT	I2407

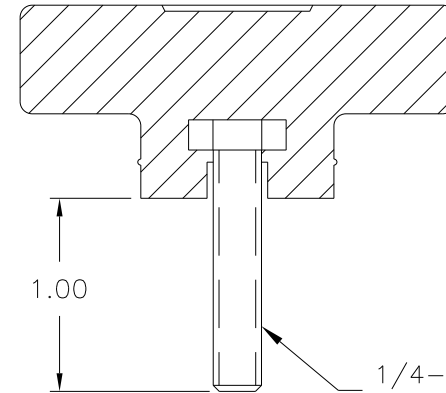
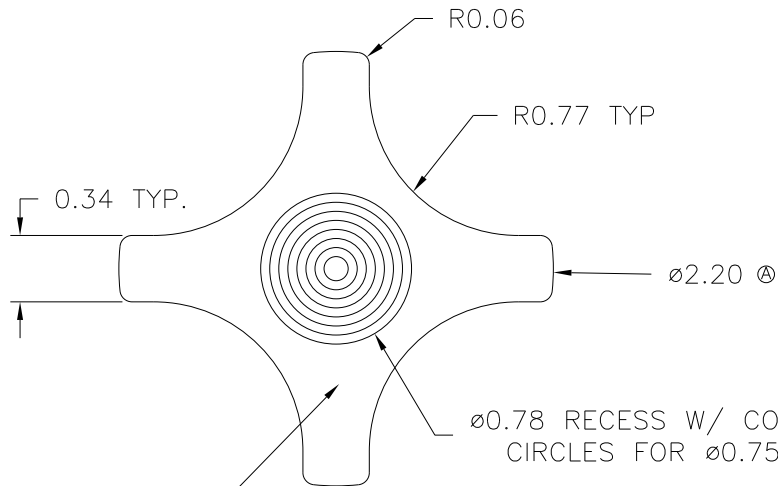

TEXTURED OUTSIDE SURFACES (UT-1090)

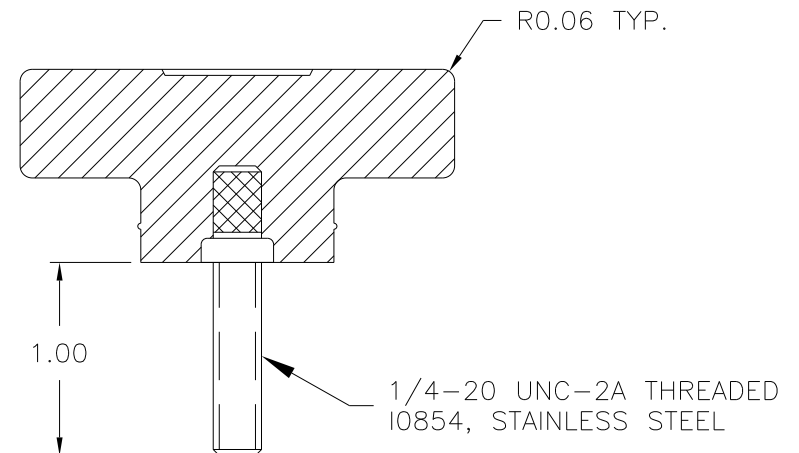
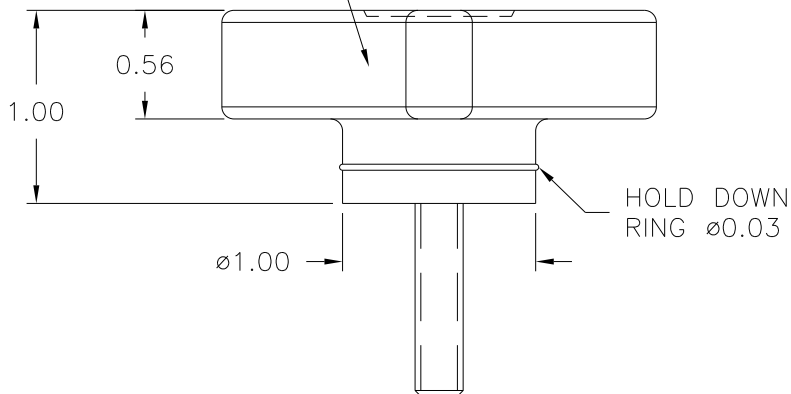

Ⓓ MATERIAL: NYLON 6/6 (ZY2), (ZY6)
OR ENGINEERING APPROVED EQUIVALENT
COLOR: BLACK

D	WAS CLC, ADDED ZY6	JAM	6/25/12
C	ADDED ALT INSERT	RF	10/2/09
B	ADDED MAT. CODE	DS	1/8/07
A	2.20 WAS 2.25	DS	4/10/06
-	REDRAWN	TL	11/22/99

TOLERANCES: UNLESS OTHERWISE SPECIFIED	DO NOT SCALE DRAWING
DECIMALS: X.XXX ± .005 X.XX ± .015	MM: X.XX ± 0.15MM X.X ± 0.4MM
FRACTIONS ± 1/64	ANG. ± 1°

CHANGES