



Chipsmall Limited consists of a professional team with an average of over 10 year of expertise in the distribution of electronic components. Based in Hongkong, we have already established firm and mutual-benefit business relationships with customers from,Europe,America and south Asia,supplying obsolete and hard-to-find components to meet their specific needs.

With the principle of “Quality Parts,Customers Priority,Honest Operation,and Considerate Service”,our business mainly focus on the distribution of electronic components. Line cards we deal with include Microchip,ALPS,ROHM,Xilinx,Pulse,ON,Everlight and Freescale. Main products comprise IC,Modules,Potentiometer,IC Socket,Relay,Connector.Our parts cover such applications as commercial,industrial, and automotives areas.

We are looking forward to setting up business relationship with you and hope to provide you with the best service and solution. Let us make a better world for our industry!



Contact us

Tel: +86-755-8981 8866 Fax: +86-755-8427 6832

Email & Skype: info@chipsmall.com Web: www.chipsmall.com

Address: A1208, Overseas Decoration Building, #122 Zhenhua RD., Futian, Shenzhen, China



IBS IL 24 RB-T-PAC

**INTERBUS branch terminal, with remote bus branch,
24 V DC**

Data sheet
6036_en_04

© PHOENIX CONTACT 2013-06-05

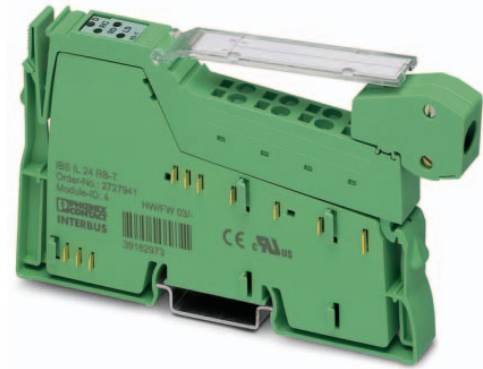

1 Description

Valid for hardware Version 0.3 or later.

The terminal is designed for use within an Inline station.

It can be used to extend the INTERBUS network by additional system levels. A total of up to 15 levels can be operated in the network.

Snapping the branch terminal onto an INTERBUS bus coupler, a control terminal, or a branch terminal opens a remote bus branch at this preconnected terminal. The branch terminal is the first terminal in the remote bus branch.

The terminal has an outgoing RS-485 remote bus interface and a combined remote bus branch/local bus interface (Inline data jumper). If an additional branch terminal is snapped onto this interface, it opens a remote bus branch. If any other device is snapped on, the interface opens a local bus.

Features

- Diagnostic indicators



This data sheet is only valid in association with the IL SYS INST UM E user manual.



Make sure you always use the latest documentation.
It can be downloaded from the product at phoenixcontact.net/products.

2	Table of contents	
1	Description	1
2	Table of contents	2
3	Ordering data	3
4	Technical data	3
5	Supplementary data	5
6	Internal circuit diagram	6
7	Local diagnostic indicators	7
8	Terminal point assignment.....	7
9	Connection example.....	7
10	Configuration notes	8
	10.1 Topology	8
	10.2 Isolated connection and disconnection.....	8

3 Ordering data

Description	Type	Order No.	Pcs. / Pkt.
INTERBUS branch terminal, complete with accessories (connector plug and labeling field), with remote bus branch, 24 V DC	IBS IL 24 RB-T-PAC	2861441	1
INTERBUS branch terminal block, 2MBD, with accessories, with remote bus branch, 24 V DC	IBS IL 24 RB-T-2MBD-PAC	2861962	1
Accessories	Type	Order No.	Pcs. / Pkt.
Inline shield connector (Plug/Adapter)	IB IL SCN-6 SHIELD	2726353	5
Labeling field, width: 12.2 mm (Marking)	IB IL FIELD 2	2727501	10
Insert strip, Sheet, white, Unlabeled, Can be labeled with: Office-Drucksysteme, Plotter: Laser printer, Mounting type: Insert, Lettering field: 62 x 10 mm (Marking)	ESL 62X10	0809492	1
Documentation	Type	Order No.	Pcs. / Pkt.
User manual, English, Automation terminals of the Inline product range	IL SYS INST UM E	-	-
Anwenderhandbuch, englisch, Projektierung und Installation der Produktfamilie Inline am INTERBUS	IB IL SYS PRO UM E	-	-

4 Technical data

Dimensions (nominal sizes in mm)

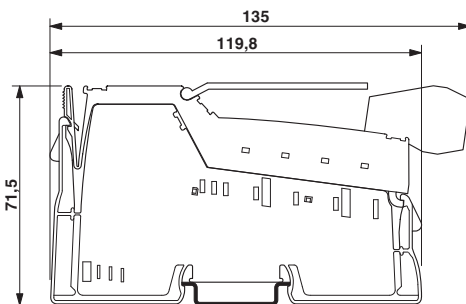

Width	12.2 mm
Height	135 mm
Depth	71.5 mm

General data

Color	green
Weight	67 g (With connector)
Ambient temperature (operation)	-25 °C ... 55 °C
Ambient temperature (storage/transport)	-25 °C ... 85 °C
Permissible humidity (operation)	10 % ... 95 % (according to DIN EN 61131-2)
Permissible humidity (storage/transport)	10 % ... 95 % (according to DIN EN 61131-2)
Air pressure (operation)	70 kPa ... 106 kPa (up to 3000 m above sea level)
Air pressure (storage/transport)	70 kPa ... 106 kPa (up to 3000 m above sea level)
Degree of protection	IP20
Protection class	III, IEC 61140, EN 61140, VDE 0140-1

Connection data

Name	Inline connectors
Connection method	Spring-cage connection
Conductor cross section solid / stranded	0.08 mm ² ... 1.5 mm ²
Conductor cross section [AWG]	28 ... 16

Interface Incoming remote bus

Connection method	Inline data jumper
-------------------	--------------------

Interface INTERBUS remote bus branch

Connection method	Inline shield connector
Transmission physics	RS-485

Interface Inline local bus

Connection method	Inline data jumper
Transmission physics	Copper

Number of local bus devices that can be connected

Number	max. 63 (Consider the logic current consumed by the devices; the branch terminal does not count as an Inline station device.)
--------	---

Transmission speed Incoming remote bus

IBS IL 24 RB-T-PAC	500 kBit/s
IBS IL 24 RB-T-2MBD-PAC	2 MBit/s

Power consumption

I/O supply voltage U_{ANA}	24 V DC (nominal value)
Current consumption from U_{ANA}	typ. 29 mA
Power consumption	max. 0.696 W (from U_{ANA})

Programming Data

ID code (hex)	04
ID code (dec.)	04
Length code (hex)	0
Length code (dec.)	0
Process data channel	0 Bit
Input address area	0 Byte
Output address area	0 Byte
Parameter channel (PCP)	0 Byte
Register length (bus)	0 Bit

PROFIBUS telegram data

Required parameter data	0 Byte
Need for configuration data	0 Byte

Error messages to the higher level control or computer system

None

Electrical isolation/isolation of the voltage areas

5 V supply, incoming remote bus, 5 V supply outgoing remote bus, 5 V supply logic 500 V AC, 50 Hz, 1 min

Remote bus branch 500 V AC, 50 Hz, 1 min

Functional earth ground 500 V AC, 50 Hz, 1 min



To achieve electrical isolation between the logic level and the I/O area, supply these areas from separate power supply units. Interconnection of the power supply units in the 24 V area is not permitted (see also user manual).

Approvals

For the latest approvals, please visit phoenixcontact.net/products.

5 Supplementary data

Power dissipation**Formula for calculating the power dissipation of the electronics**

$$P_{TOT} = U_{ANA} \times I_{TOT}$$

Where:

P_{EL}	Total power dissipation in the terminal
U_{ANA}	Analog voltage
I_{TOT}	Total current consumption in the branch terminal at U_{ANA}

Example:

$$P_{TOT} = 24 \text{ V} \times 29 \text{ mA} = 696 \text{ mW}$$

Power dissipation of the housing

Maximum 0.7 W (within the permissible operating temperature)

6 Internal circuit diagram

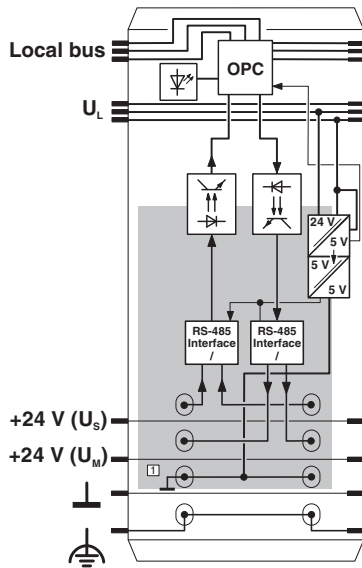



Figure 1 Internal wiring of the terminal points

Key:

OPC Protocol chip
(Bus logic including voltage conditioning)

 LED (status indicator)

 Optocoupler

 Power supply unit with electrical isolation

 Ground, electrically isolated from ground of the GND potential jumper

RS-485 Interface component

 Electrically isolated area



Explanation for other used symbols has been provided in the IL SYS INST UM E user manual.

7 Local diagnostic indicators



Figure 2 Local diagnostic indicators

Designation	Color	Meaning
D	Green	Diagnostics (bus and logic voltage)
RC	Green	Remote bus cable check
RD	Yellow	Remote bus disconnected
LD	Yellow	Remote bus branch/local bus disconnected
	Red	Isolated disconnection of remote bus branch/local bus after error

RD ON: the remote bus, which is connected to the shield plug, is disconnected.

Possible causes:

- This interface or an upstream interface has been disconnected.
- INTERBUS is not running (in the RUN state).



If, in the event of an error, the upstream bus coupler disconnects its remote bus branch/local bus interface in isolation, the RD and LD LEDs would light up on this branch terminal.

Function identification

Gray

8 Terminal point assignment

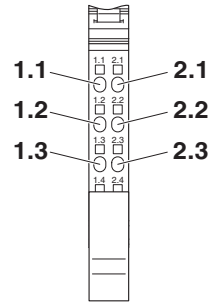

Figure 3 Terminal point assignment

Terminal point	Assignment		Remark/conductor color in the INTERBUS standard cable
1.1	/DO	Receive data	Green
2.1	DO	Receive data	Yellow
1.2	/DI	Transmit data	Pink
2.2	DI	Transmit data	Gray
1.3	GND	Reference potential	Brown
2.3	-	Not used	-
1.4, 2.4	Shield		Shield potential is connected directly to functional earth ground (FE) of the potential jumper.

9 Connection example

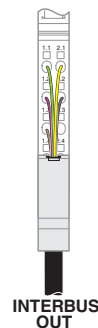

Figure 4 Typical connection of the INTERBUS cables

10 Configuration notes

10.1 Topology

In terms of topology, the remote bus branch, which is opened at the interface of the branch terminal, is located between the bus coupler and the branch terminal.

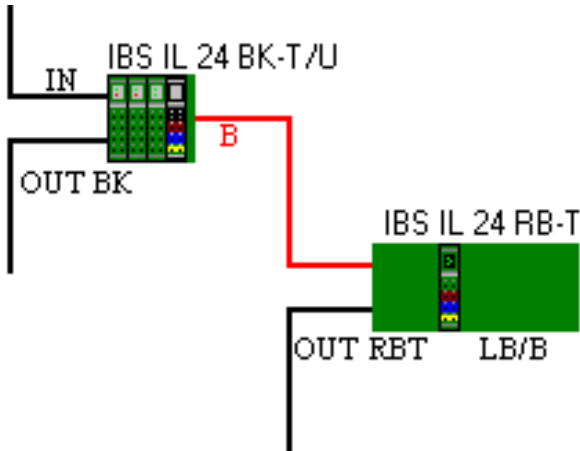

Figure 5 Bus coupler/branch terminal topology

IN	Incoming remote bus
OUT BK	Bus coupler outgoing remote bus
B	Remote bus branch (internal interface)
OUT RB-T	Branch terminal outgoing remote bus
LB/B	Local bus (LB; in the event of subsequent I/O terminals) or Remote bus branch (B, in the event of a subsequent branch terminal)

The branch terminal can only be installed directly after a bus coupler, a control terminal or a branch terminal.

This means that a device with a protocol chip must not be present between the previous terminal and the relevant branch terminal.

You can use up to 15 Phoenix Contact branch terminals after the bus couplers and control terminals.



Observe the restrictions and notes provided in the terminal-specific data sheets for your application.

10.2 Isolated connection and disconnection



Please note that isolated connection and disconnection in the event of an error is only possible with remote bus branch and local bus interfaces. Isolated connection and disconnection in the event of an error is not possible with a remote bus interface.

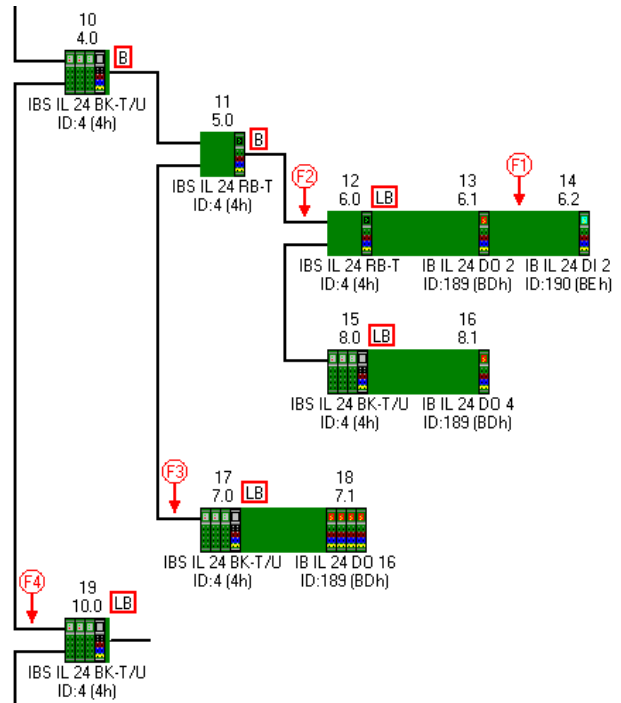

Figure 6 Example for isolated connection and disconnection in the event of an error

Isolated connection and disconnection in the event of an error can be parameterized on all the bus couplers and branch terminals shown. Isolated disconnection in the event of an error is performed at the following points:

B	(Remote bus branch)	Remote bus branch
LB	(Local bus)	Local bus

The following happens if the corresponding error occurs:

F1: error in the local bus of an Inline station:

The local bus interface is disconnected in isolation at the previous branch terminal (parameterized for this purpose) or the previous bus coupler (parameterized for this purpose).

Example F1:

Error in the local bus of station 6:

The local bus interface of branch terminal 6.0 is disconnected. The entire bus continues to run except for the disconnected local bus (6.1, 6.2).

F2/F3: error in a remote bus branch or a remote bus which, in terms of topology, is located in a branch

The remote bus branch interface is disconnected in isolation at the previous branch terminal (parameterized for this purpose) or the previous bus coupler (parameterized for this purpose).

Example F2:

Error between **5.0 and 6.0** (remote bus branch)

or

Error between **6.0 and 8.0** (remote bus which, in terms of topology, is located in a branch):

Remote bus branch at 5.0 is disconnected in isolation. This disconnects devices 6.x and 8.x.

Example F3:

Error between **5.0 and 7.0**

(remote bus which, in terms of topology, is located in a branch):

Remote bus branch at 4.0 is disconnected in isolation. This disconnects devices 5.0, 6.x, 8.x, and 7.x.

F4: Error on remote bus

Isolated disconnection of a remote bus interface is not possible in the event of an error. A bus error causes bus downtime.

Example F4:

Error between 4.0 and 10.0:

Bus error with bus downtime.

Restrictions/special features**Branch terminal with hardware version < 0.3 (HW < 0.3)**

Only one branch terminal with HW < 03 may be used within an Inline station. Operating several of these terminals one after the other is not permitted. Mixed operation of branch terminals with HW < 0.3 and HW > 0.3 is not permitted within a station.