



Chipsmall Limited consists of a professional team with an average of over 10 year of expertise in the distribution of electronic components. Based in Hongkong, we have already established firm and mutual-benefit business relationships with customers from,Europe,America and south Asia,supplying obsolete and hard-to-find components to meet their specific needs.

With the principle of “Quality Parts,Customers Priority,Honest Operation,and Considerate Service”,our business mainly focus on the distribution of electronic components. Line cards we deal with include Microchip,ALPS,ROHM,Xilinx,Pulse,ON,Everlight and Freescale. Main products comprise IC,Modules,Potentiometer,IC Socket,Relay,Connector.Our parts cover such applications as commercial,industrial, and automotives areas.

We are looking forward to setting up business relationship with you and hope to provide you with the best service and solution. Let us make a better world for our industry!



Contact us

Tel: +86-755-8981 8866 Fax: +86-755-8427 6832

Email & Skype: info@chipsmall.com Web: www.chipsmall.com

Address: A1208, Overseas Decoration Building, #122 Zhenhua RD., Futian, Shenzhen, China



ILB DN 24 DI16 DO16

Inline Block IO Module for DeviceNet™ With 16 Digital Inputs and 16 Digital Outputs

AUTOMATIONWORX

Data Sheet
6885_en_05

© PHOENIX CONTACT - 03/2007

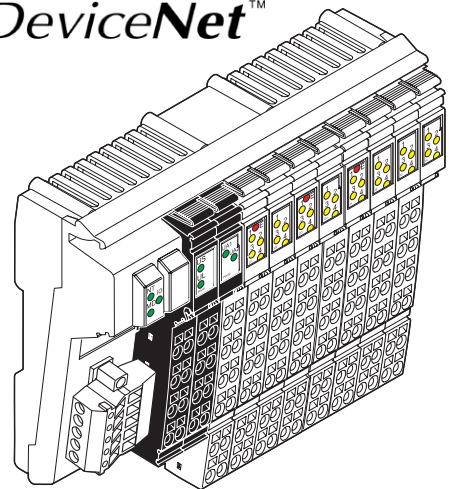

Description

The ILB DN 24 DI16 DO16 module is designed for use within a DeviceNet™ network. It is used to acquire and output digital signals.

DeviceNet™ Features

- I/O peer-to-peer communication
- Direct peer-to-peer communication
- Consistent configuration
- Faulted node recovery
- Baud rates: 125 kbaud, 250 kbaud, 500 kbaud
- I/O slave messages:
Polling, cyclic transmission,
change of state (COS), bit strobing

Input Features

- Connections for 16 digital sensors
- Connection of sensors in 2 and 3-wire technology
- Maximum permissible load current per sensor: 125 mA
- Maximum permissible load current from the sensor supply: 2.0 A
- Diagnostic and status indicators

Output Features

- Connections for 16 digital actuators
- Connection of actuators in 2 and 3-wire technology
- Nominal current per output: 0.5 A
- Total current of all outputs: 8 A
- Short-circuit and overload protected outputs
- Diagnostic and status indicators



Please refer to the "Mounting and Removing Inline Block IO Modules" application note (see "Ordering Data" on page 2).



Make sure you always use the latest documentation.
It can be downloaded at www.download.phoenixcontact.com.
Here you will also find the current EDS file.

A conversion table is available on the Internet at
www.download.phoenixcontact.com/general/7000_en_00.pdf.

Ordering Data

Product

Description	Type	Order No.	Pcs./Pkt.
Inline Block IO module for DeviceNet™ with 16 digital inputs and 16 digital outputs	ILB DN 24 DI16 DO16	2862602	1

Accessories: Connector

Description	Type	Order No.	Pcs./Pkt.
TWIN-COMBICON connector for bus connection	TMSTBP 2,5/ 5-STF-5,08 GNAU CP	2862576	1

Accessories: Connectors as Replacement Item

Description	Type	Order No.	Pcs./Pkt.
Connector for the supply (color print)	IB IL SCN-PWR IN-CP	2727637	5
Connector, with color print, for digital 4-channel or 16-channel Inline output terminals	IB IL SCN-12-OPC	2727624	10
Connector, with color print, for digital 4-channel or 16-channel Inline input terminals	IB IL SCN-12-IPC	2727611	10

Accessories: Other

Description	Type	Order No.	Pcs./Pkt.
Recommended end clamp; placed both to the right and left of the module to secure it on the DIN rail	CLIPFIX 35-5	3022276	50

Documentation

Description	Type	Order No.	Pcs./Pkt.
"Mounting and Removing Inline Block IO Modules" application note	AH ILB INSTALLATION	9014931	1
"Configuring a DeviceNet™ System Using Devices in the Fieldline Product Range" user manual	FLS FLM DN SYS PRO UM E	2699082	1
"Addressing of 16-Channel ILB Modules" application note	AH ILB 24 DI/DO 16 ADDRESS	9014962	1

Technical Data

General Data

Housing dimensions with connectors (width x height x depth)	156 mm x 55 mm x 141 mm
Weight	500 g, approximately (with connectors)
Operating mode	Process data mode with 4 bytes
Transmission speed	125 kbaud, 500 kbaud
Type of sensor and actuator connection	2 and 3-wire technology

Housing Dimensions

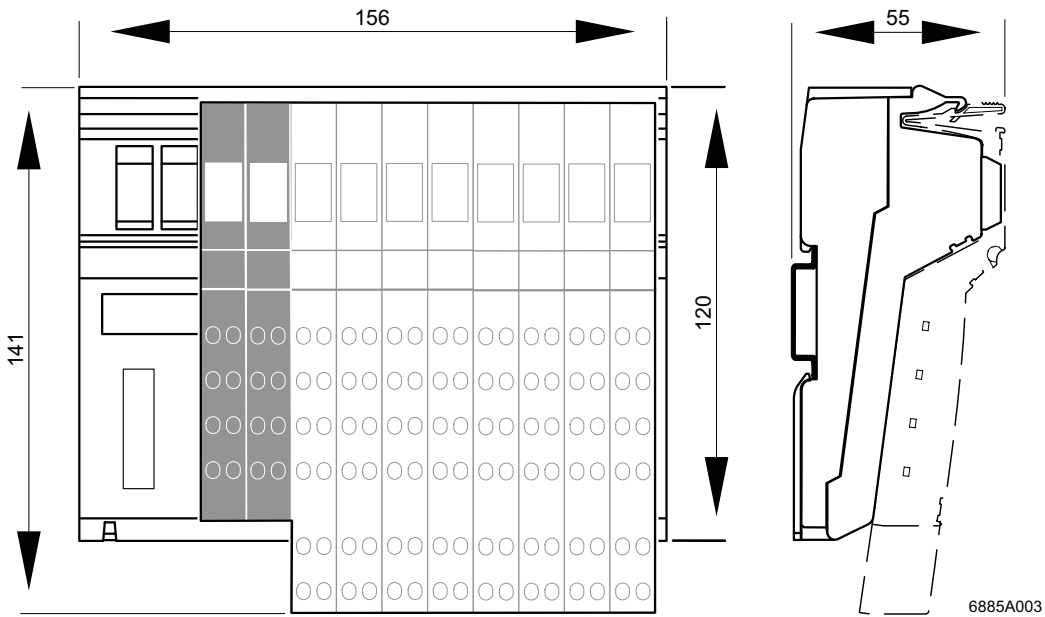

Figure 1 Housing dimensions of the module (dimensions in mm)

Ambient Conditions

Regulations	Developed according to VDE 0160/EN 50178/IEC 62103, UL 508
Ambient temperature (operation)	-25°C to +60°C
Ambient temperature (storage/transport)	-25°C to +85°C
Humidity (operation/storage/transport)	10% to 95% according to EN 61131-2
Air pressure (operation)	80 kPa to 108 kPa (up to 2000 m above sea level)
Air pressure (storage/transport)	66 kPa to 108 kPa (up to 3500 m above sea level)
Degree of protection according to IEC 60529	IP20
Class of protection	Class 3 according to VDE 0106/IEC 60536
Air and creepage distances	According to DIN VDE 0110/IEC 60664, IEC 60664A, DIN VDE 0160/EN 50178/IEC 62103
Housing material	Plastic, PVC-free, PBT, self-extinguishing (V0)
Pollution degree according to EN 60664-1/IEC 60664-1, EN 61131-2/IEC 61131-2	2; condensation not permitted during operation
Surge voltage class	II

Electrical Isolation/Isolation of the Voltage Areas**Test Distance**

Test Distance	Test Voltage
DeviceNet™ / I/O	500 V AC, 50 Hz, 1 min
DeviceNet™ / functional earth ground	500 V AC, 50 Hz, 1 min
I/O / functional earth ground	500 V AC, 50 Hz, 1 min

Mechanical Requirements

Vibration test, sinusoidal vibrations according to EN 60068-2-6/IEC 60068-2-6	5g load, 2.5 hours in each space direction
Shock test according to EN 60068-2-27/IEC 60068-2-27	25g load for 11 ms, half sinusoidal wave, 3 shocks in each space direction and orientation
Broadband noise according to EN 60068-2-64/IEC 60068-2-64	0.78g load, 2.5 hours in each space direction

Conformance With EMC Directive 89/336/EEC**Noise Immunity Test According to EN 61000-6-2**

Electrostatic discharge (ESD)	EN 61000-4-2 IEC 61000-4-2	Criterion B 6 kV contact discharge 8 kV air discharge
Electromagnetic fields	EN 61000-4-3 IEC 61000-4-3	Criterion A Field strength: 10 V/m
Fast transients (burst)	EN 61000-4-4/ IEC 61000-4-4	Criterion B Remote bus: 2 kV Power supply: 2 kV I/O cables: 2 kV Criterion A All interfaces: 1 kV
Surge voltage	EN 61000-4-5 IEC 61000-4-5	Criterion B DC supply lines: ± 0.5 kV/ ± 1.0 kV (symmetrical/asymmetrical) Signal cables: ± 0.5 kV/ ± 0.5 kV (symmetrical/asymmetrical)
Conducted interference	EN 61000-4-6 IEC 61000-4-6	Criterion A Test voltage 10 V

Noise Emission Test According to EN 61000-6-4

Noise emission of housing	EN 55011	Class A
---------------------------	----------	---------

Interface

DeviceNet™ interface	RS-485; COMBICON connector; shielding directly connected with functional earth ground
----------------------	--

24 V Module Supply**Communications Power U_L**

Nominal value	24 V DC
Tolerance	11 V DC to 25 V DC according to the ODVA specification
Ripple	$\pm 5\%$ according to EN 61131-2
Permissible range	11.0 V DC to 30.0 V DC
Current consumption at U_L	25 mA
Safety equipment	Surge protection and protection against polarity reversal
Connection	Via power connectors

24 V Module Supply (Continued)**Sensor and Actuator Supply; U_S and U_A**

Nominal value	24 V DC
Tolerance	-15%/+20% according to EN 61131-2
Ripple	±5% according to EN 61131-2
Permissible range	19.2 V DC to 30.0 V DC
Current consumption at U_S	2 A
Current consumption at U_{A1} and U_{A2}	2 x 4 A
Safety equipment for the sensor supply	Surge, overload and short-circuit protection
Safety equipment for the actuator supply	Surge protection
Connection	Via power connectors

Digital Outputs

Number	16
Connection method for actuators	2 and 3-wire technology
Nominal output voltage U_{OUT}	24 V DC
Differential voltage at I_{nom}	≤ 1 V
Nominal current I_{nom} per channel	0.5 A
Total current	2 x 4 A
Protection	Short-circuit and overload protection
Nominal load	
Ohmic	48 Ω/12 W
Lamp	12 W
Inductive	12 VA (1.2 H, 50 Ω)
Switching frequency with nominal inductive load	0.5 Hz (1.2 H, 50 Ω), maximum
Overload response	Auto restart
Response with inductive overload	Output may be damaged
Reverse voltage protection against short pulses	Protected against reverse voltages
Resistance to permanently applied reverse voltages	Protected against reverse voltages, permissible current 2 A, maximum
Validity of output data after connecting the 24 V supply voltage (power up)	5 ms, typical
Response upon power down	The output follows the supply voltage without delay.
Limitation of the voltage induced on circuit interruption	-41.0 V
One-time unsolicited energy	1 J, maximum
Protective circuit type	Integrated free running circuit in the output chip
Overcurrent shutdown	0.7 A, minimum
Maximum output current when switched off	10 μA



When not loaded, a voltage can be measured even at an output that is not set.

Digital Inputs	
Number	16
Connection method for sensors	2 and 3-wire technology
Input design	According to EN 61131-2 Type 1
Definition of switching thresholds	
Maximum low-level voltage	$U_{Lmax} < 5 \text{ V}$
Minimum high-level voltage	$U_{Hmin} > 15 \text{ V}$
Common potentials	Sensor supply U_S , ground
Nominal input voltage U_{IN}	24 V DC
Permissible range	$-30 \text{ V} < U_{IN} < +30 \text{ V DC}$
Nominal input current for U_{IN}	5 mA, typical
Current flow	Linear in the range $1 \text{ V} < U_{IN} < 30 \text{ V}$
Delay time	$\leq 500 \mu\text{s}$
Permissible cable length to the sensor	100 m
Use of AC sensors	AC sensors in the voltage range $< U_{IN}$ are limited in application

Power Dissipation

Formula to Calculate the Power Dissipation of the Electronics

$P_{TOT} = 1.92 \text{ W} + I_S^2 \times 0.06 \Omega + \sum_{i=1}^n (0.04 \text{ W} + I_{Li}^2 \times 0.28 \Omega) + \sum_{j=1}^m 0.125 \text{ W}$	<p>Where</p> <p>P_{TOT} Total power dissipation of the module</p> <p>I_S Current from the sensor supply</p> <p>i Index</p> <p>n Number of set outputs ($n = 1$ to 16)</p> <p>I_{Li} Load current of the output i</p> <p>j Index</p> <p>m Number of set inputs ($m = 1$ to 16)</p>
--	---

Limitation of Simultaneity, Derating

No limitation of simultaneity, no derating

Approvals

For the latest approvals, please visit www.download.phoenixcontact.com.



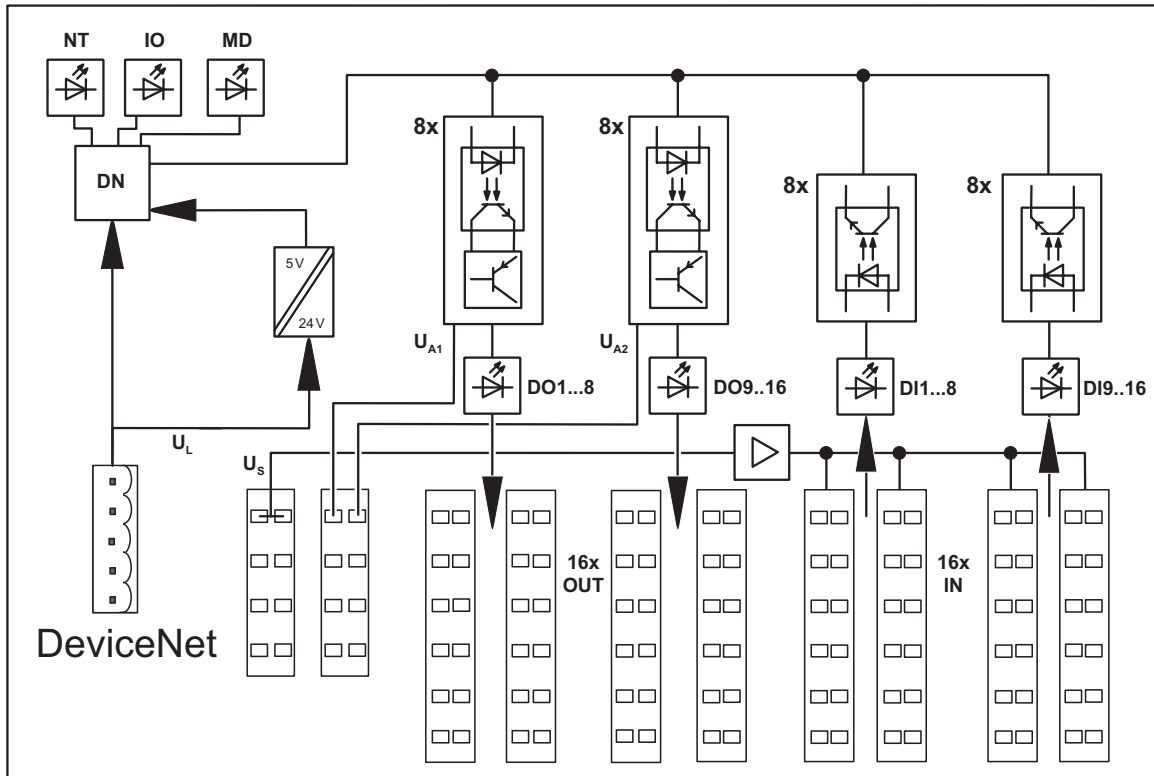



Internal Circuit Diagram



6885A002

Figure 2 Internal wiring of the terminal points

Key:

-  LED
-  DeviceNet™ protocol chip (bus logic)
-  Power supply unit with electrical isolation
-  Optocoupler
-  Short-circuit-proof output
-  Short-circuit-proof sensor supply

Local Diagnostic and Status Indicators

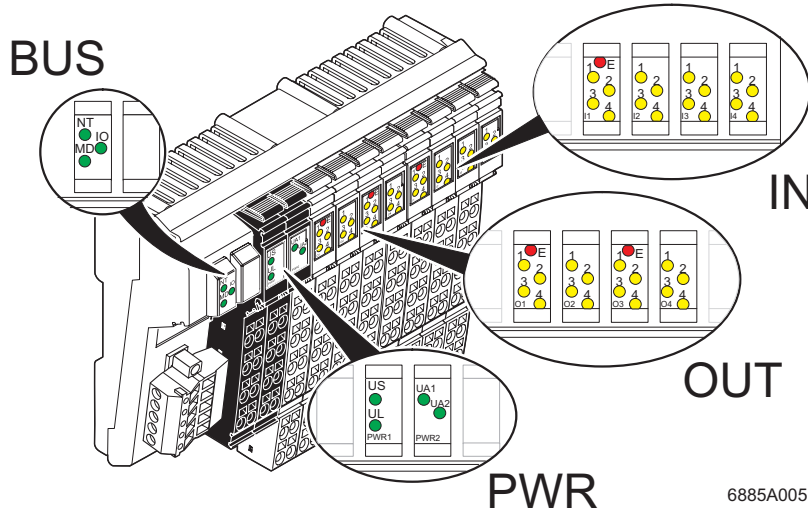

Figure 3 Diagnostic and status indicators of the ILB DN 24 DI16 DO16 module

Designation	Color	Meaning
BUS		
NT	Red/green LED	Network status
	ON (green)	Module online, connection established. Group 2 devices are assigned to a master.
	ON (red)	Error that prevents communication with the network (e.g., bus offline or double device ID).
	Flashing (green)	Device online, connections not established. Device has finished the "Dup_MAC_ID" test but has not established connections to other nodes. Group 2 devices are not assigned to a master.
	Flashing (red)	One or more connections are in timeout state.
	Flashing (red-green)	Network access error
	OFF	Device not online. Device has not yet finished the "Dup_MAC_ID" test. Device is not supplied with voltage.

Designation	Color	Meaning
IO	Red/green LED	I/O status (input/output)
	ON (green)	One or more outputs are active, no error state is present.
	ON (red)	Error parameterization due to undervoltage or overload at U_S
	Flashing (green)	Error parameterization due to undervoltage at +24 V DC or at U_A
	Flashing (red)	Inputs and outputs maintain their state despite error message. Error parameterization is not active. Error state detected due to undervoltage at +24 V DC or U_A .
	Flashing (red-green)	Baud rate setting/detection (autobaud)
	OFF	No output is active, no error state is present.
MD	Red/green LED	Device status (module diagnostics)
	ON (green)	Normal operation
	ON (red)	Unrecoverable error
	Flashing (green)	– Device not configured, or device configuration not complete or faulty – Device in standby mode
	Flashing (red)	Recoverable error
	Flashing (red-green)	Selftest
	OFF	No supply voltage
PWR		
US	Green	Sensor supply
UL	Green	24 V communications power
UA1	Green	Actuator supply 1 (connector 3 and connector 4 for actuators)
UA2	Green	Actuator supply 2 (connector 5 and connector 6 for actuators)
OUT		
E	Red	Short circuit or overload at one of the outputs
1 - 4	Yellow	Status indicators of the outputs
IN		
E	Red	Short circuit or overload of the sensor supply
1 - 4	Yellow	Status indicators of the inputs



The NT, IO and MD LEDs may flash green and red at the same time.



If the error LED (E) of a group of 8 outputs is on (e.g., connector 3 and connector 4), this indicates that a short circuit or overload is present at one or more of the outputs in this group.



Default setting of the error parameterization:

- All outputs are deactivated.
- All inputs remain unchanged.

Setting the Address and Baud Rate

Configure the hardware on the module using the 10-pos. DIP switch. This switch can be used to set both the DeviceNet™ address and the baud rate. For the meaning of the switches, please refer to the following tables.

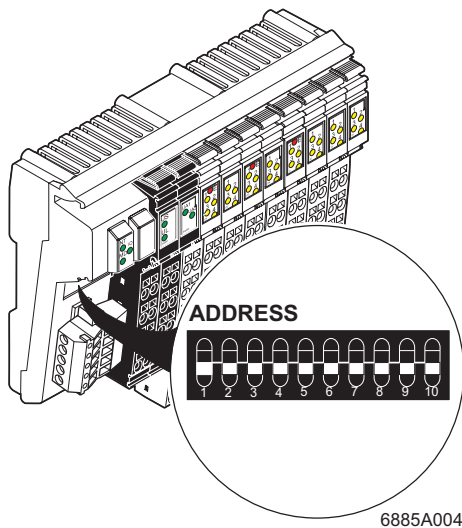

Figure 4 DIP switches of the module

DIP switch 1 (SW1) is the MSB (most significant bit) of the node ID and DIP switch 7 (SW7) is the LSB (least significant bit).



Switch the power off and back on to accept address changes.

DIP Switch Address Settings (MAC ID)

	SW1	SW2	SW3	SW4	SW5	SW6	SW7
ON	64	32	16	8	4	2	1
OFF	0	0	0	0	0	0	0

The DeviceNet™ transmission speed is set using DIP switches 8 to 10. The following table shows the switch settings for different baud rates.

DIP Switch Baud Rate Settings

SW8	SW9	SW10	Baud Rate
ON	ON	OFF	Can be set using software
ON	OFF	OFF	500 kbaud
OFF	ON	OFF	250 kbaud
OFF	OFF	OFF	125 kbaud
ON	ON	ON	Auto (default)

Connecting DeviceNet™, the Supply, Actuators, and Sensors

Connecting DeviceNet™

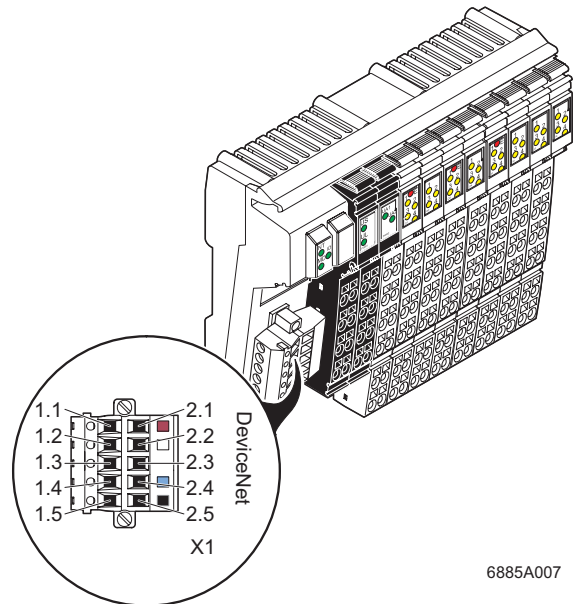

Figure 5 Pin assignment of the TWIN-COMBICON connector

Connect the DeviceNet™ via a TWIN-COMBICON connector to the module. For the pin assignment, please refer to the following table:

Pin	Color	Signal	Description
1.1, 2.1	Red	V+	+24 V DC for U _L
1.2, 2.2	White	CAN H	CAN High
1.3, 2.3	Bare	Drain	Shield
1.4, 2.4	Blue	CAN L	CAN Low
1.5, 2.5	Black	V-	GND



In the DeviceNet™ system, a termination resistor (121 Ω / 0.25 W with 1% tolerance) must be fitted at each end of the main line.

Connecting the Supply, Actuators, and Sensors

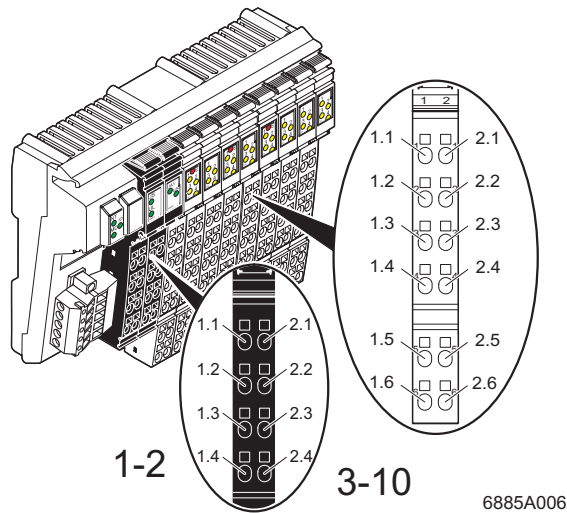

Figure 6 Terminal point assignment of Inline connectors

Terminal Point Assignment of Power Connectors (Connectors 1 and 2 in Figure 6)

Terminal Point	Assignment
Connector 1 (PWR 1)	
1.1, 2.1	24 V sensor supply U_S
1.2, 2.2	24 V communications power U_L , (voltage for module test, not intended for use within the DeviceNet™ network)
1.3, 2.3	GND
1.4, 2.4	FE
Connector 2 (PWR 2)	
1.1, 2.1	24 V actuator supply U_{A1}, U_{A2}
1.2, 2.2	24 V communications power U_L , (voltage for module test, not intended for use within the DeviceNet™ network)
1.3, 2.3	GND
1.4, 2.4	FE



If the module is used in a DeviceNet™ network, U_L must be connected to the COMBICON connector. Therefore, connect U_L to the COMBICON connector at pin V+ and pin V-. The connection options at Inline connectors 1 and 2 are designed for test purposes only.



The terminal points can have a total current of 8 A per terminal point. The maximum current carrying capacity of 8 A must not be exceeded. If the total output current in your application is > 8 A, supply the module via a minimum of two terminal points connected in parallel.



The supply points have the same ground potential. All ground supplies on a module are electrically connected with one another. The communications power is also electrically connected via all contacts. In this way, it can supply all potentials with just one supply without the need for additional terminals, see "Connection Example" on page 13.

Terminal Point Assignment of Output Connectors (Connectors 3 to 6 in Figure 6 on page 11)

Terminal Point				Assignment
Connector 3 (O1)	Connector 4 (O2)	Connector 5 (O3)	Connector 6 (O4)	
1.1, 2.1	1.1, 2.1	1.1, 2.1	1.1, 2.1	Signal output (OUT)
1.2, 2.2	1.2, 2.2	1.2, 2.2	1.2, 2.2	Ground contact (GND) for 2 and 3-wire termination
1.3, 2.3	1.3, 2.3	1.3, 2.3	1.3, 2.3	FE connection for 3-wire termination
1.4, 2.4	1.4, 2.4	1.4, 2.4	1.4, 2.4	Signal output (OUT)
1.5, 2.5	1.5, 2.5	1.5, 2.5	1.5, 2.5	Ground contact (GND) for 2 and 3-wire termination
1.6, 2.6	1.6, 2.6	1.6, 2.6	1.6, 2.6	FE connection for 3-wire termination

Terminal Point Assignment of Input Connectors (Connectors 7 to 10 in Figure 6 on page 11)

Terminal Point				Assignment
Connector 7 (I1)	Connector 8 (I2)	Connector 9 (I3)	Connector 10 (I4)	
1.1, 2.1	1.1, 2.1	1.1, 2.1	1.1, 2.1	Signal input (IN)
1.2, 2.2	1.2, 2.2	1.2, 2.2	1.2, 2.2	Sensor voltage for 2 and 3-wire termination
1.3, 2.3	1.3, 2.3	1.3, 2.3	1.3, 2.3	Ground contact (GND) for 3-wire termination
1.4, 2.4	1.4, 2.4	1.4, 2.4	1.4, 2.4	Signal input (IN)
1.5, 2.5	1.5, 2.5	1.5, 2.5	1.5, 2.5	Sensor voltage for 2 and 3-wire termination
1.6, 2.6	1.6, 2.6	1.6, 2.6	1.6, 2.6	Ground contact (GND) for 3-wire termination

Connection Example

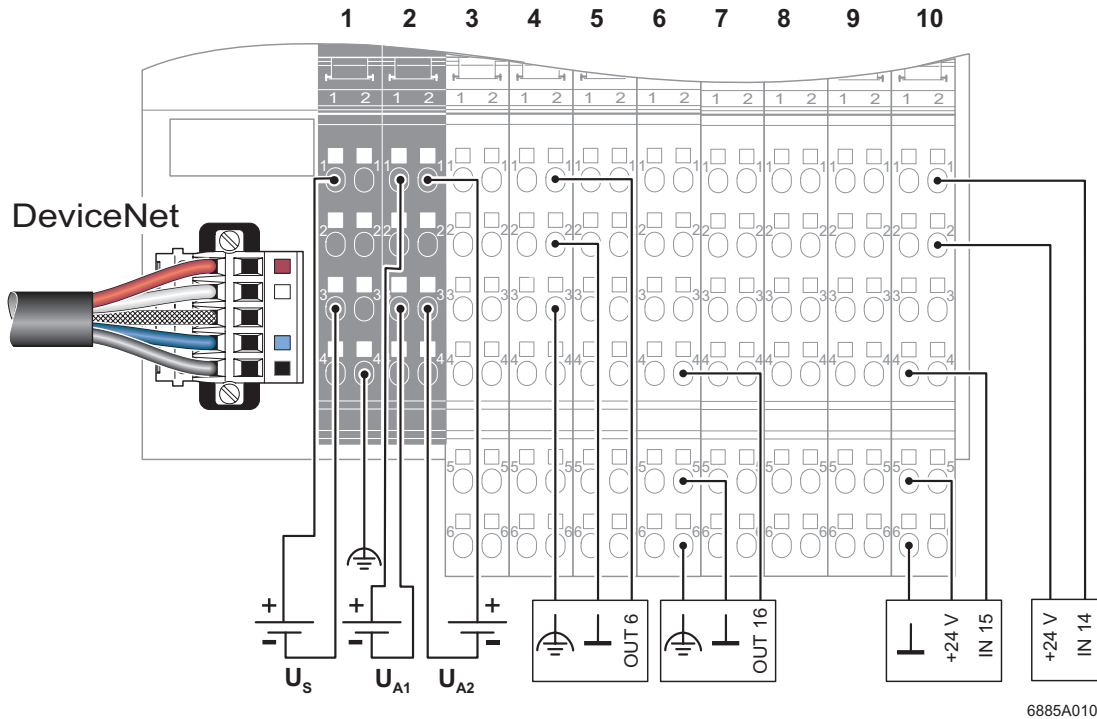

6885A010

Figure 7 Connection example



If the module is used in a DeviceNet™ network, U_L must be connected to the COMBICON connector. Therefore, connect U_L to the COMBICON connector at pin V+ and pin V-.
The connection options at Inline connectors 1 and 2 are designed for test purposes only (see "Terminal Point Assignment of Power Connectors (Connectors 1 and 2 in Figure 6)" on page 11).



The numbers above the module illustration identify the connector slots.



The module has an FE spring (metal clip) on the bottom of the electronics base. This spring creates an electrical connection to the DIN rail. Use grounding terminals to connect the DIN rail to protective earth ground. The module is grounded when it is snapped onto the DIN rail.
To ensure reliable functional earth grounding of the module even when the DIN rail is dirty or the metal clip is damaged, Phoenix Contact also recommends grounding the module via one of the FE terminal points.

Device Data

ID number	120 _{hex}
Input address area	4 bytes
Output address area	4 bytes

Process Data

Input Address Area (Produced Process Data)			
Byte 0 (inputs)	Byte 1 (inputs)	Byte 2 (reading back output byte 0)	Byte 3 (reading back output byte 1)

Output Address Area (Consumed Process Data)			
Byte 0	Byte 1	Reserved	Reserved



Please refer to the application note for addressing 16-channel ILB modules.
 The documentation can be downloaded at www.download.phoenixcontact.com.
 Here you will also find the current EDS file.

Assignment of Terminal Points to the OUT Process Data Word (Slots 3 to 6)

(Word.bit) view	Word	Word 0															
	Bit	15	14	13	12	11	10	9	8	7	6	5	4	3	2	1	0
(Byte.bit) view	Byte	Byte 0								Byte 1							
	Bit	7	6	5	4	3	2	1	0	7	6	5	4	3	2	1	0
Module	Slot	4 (O2)				3 (O1)				6 (O4)				5 (O3)			
	Terminal point (signal)	2.4	1.4	2.1	1.1	2.4	1.4	2.1	1.1	2.4	1.4	2.1	1.1	2.4	1.4	2.1	1.1
	Terminal point (GND)	2.5	1.5	2.2	1.2	2.5	1.5	2.2	1.2	2.5	1.5	2.2	1.2	2.5	1.5	2.2	1.2
	Terminal point FE	2.6	1.6	2.3	1.3	2.6	1.6	2.3	1.3	2.6	1.6	2.3	1.3	2.6	1.6	2.3	1.3
Status indicator	Slot	4 (O2)				3 (O1)				6 (O4)				5 (O3)			
	LED	4	3	2	1	4	3	2	1	4	3	2	1	4	3	2	1

Assignment of Terminal Points to the IN Process Data Word (Slots 7 to 10)

(Word.bit) view	Word	Word 0															
	Bit	15	14	13	12	11	10	9	8	7	6	5	4	3	2	1	0
(Byte.bit) view	Byte	Byte 0								Byte 1							
	Bit	7	6	5	4	3	2	1	0	7	6	5	4	3	2	1	0
Module	Slot	8 (I2)				7 (I1)				10 (I4)				9 (I3)			
	Terminal point (signal)	2.4	1.4	2.1	1.1	2.4	1.4	2.1	1.1	2.4	1.4	2.1	1.1	2.4	1.4	2.1	1.1
	Terminal point (24 V)	2.5	1.5	2.2	1.2	2.5	1.5	2.2	1.2	2.5	1.5	2.2	1.2	2.5	1.5	2.2	1.2
	Terminal point (GND)	2.6	1.6	2.3	1.3	2.6	1.6	2.3	1.3	2.6	1.6	2.3	1.3	2.6	1.6	2.3	1.3
Status indicator	Slot	8 (I2)				7 (I1)				10 (I4)				9 (I3)			
	LED	4	3	2	1	4	3	2	1	4	3	2	1	4	3	2	1

Diagnostic Data

Mapping of Diagnostic Data in DeviceNet™ (Class 1, Attribute 5)

Diagnostic Data	Bit 7	Bit 6	Bit 5	Bit 4	Bit 3	Bit 2	Bit 1	Bit 0
Byte 0	Reserved	Initiator supply	24 V supply voltage	Undervoltage U_L	Reserved	Reserved	Reserved	Reserved
Byte 1	Reserved	Reserved	Reserved	Reserved	Not configured or unknown I/O	Error handling active	Module type unknown	Short circuit of digital outputs



An error is indicated in class 1, attribute 5 when the respective bit value is "1".

Class 102, Attribute 103 (Error Information)

(Byte:bit) view	Byte		Byte 0							
	Bit	Error	7	6	5	4	3	2	1	0
Device		Error	0: NMV has been re-initialized (possibly due to a hardware fault). 1: NMV has been initialized correctly with a corresponding parameterization at Phoenix Contact.	Reserved	U_S failure	U_S overload	Actuator supply failure	Short circuit of digital outputs	Communications power failure at COMBICON connector	Communications power failure at Inline connector



An error is indicated in class 102, attribute 103 when the respective bit value is "0".

Error Table With Diagnostic Data and Status Indicators

Error Type	Diagnostic Data	Status Indicators
Sensor voltage U_S too low	Class 102, attribute 103 Byte 0 bit 5 is set to "0"	US LED is off. IO LED is red.
Actuator supply U_{A1} or U_{A2} too low	Class 102, attribute 103 Byte 0 bit 3 is set to "0"	UA1 or UA2 LED is off. IO LED flashes green or red if no error parameterization is activated.
Short circuit of a sensor supply	Class 102, attribute 103 Byte 0 bit 4 is set to "0"	E LED of the sensor supply is red. IO LED is red.
Short circuit of a digital output	Class 102, attribute 103 Byte 0 bit 2 is set to "0"	E LED of the affected output group is red. IO LED is green.

The output behavior in the event of an error is parameterized using the "Discrete Output Point Object" (09_{dec}, 09_{hex})(DOP). Outputs are reset by default.



For additional information, please refer to the FLS FLM DN SYS PRO UM E user manual (see "Ordering Data" on page 2).

Attributes of the Connection Object (05_{dec}, 05_{hex}) Class

The Connection Object class describes the individual connection types. The following tables have been taken from the ODVA specification for DeviceNet™.

Attributes of the Connection Object Class

Attribute	Requirement	Attribute Name	Type	Short Description (According to ODVA)
1	Required	State	USINT	State of the object
2	Required	instance_type	USINT	Indicates either I/O or Messaging Connection
3	Required	transportClass_trigger	BYTE	Defines behavior of the Connection
4	Required	produced_connection_id	UINT	Placed in CAN Identifier Field when the Connection transmits
5	Required	consumed_connection_id	UINT	CAN Identifier Field value that denotes message to be received
6	Required	initial_comm_characteristics	BYTE	Defines the Message Group(s) across which productions and consumptions associated with this Connection occur
7	Required	produced_connection_size	UINT	Maximum number of bytes transmitted across this Connection
8	Required	consumed_connection_size	UINT	Maximum number of bytes received across this Connection

Attribute	Requirement	Attribute Name	Type	Short Description (According to ODVA)
9	Required	expected_packet_rate	UINT	Defines timing associated with this Connection
10, 11	N/A	N/A	N/A	Not used. These attribute IDs have been obsoleted and are no longer defined for a Connection Object
12	Required	watchdog_timeout_action	USINT	Defines how to handle Inactivity/ Watchdog Timeouts
13	Required	produced_connection_path_length	UINT	Number of bytes in the produced_connection_path attribute
14	Required	produced_connection_path	Array of USINT	Specifies the Application Object(s) whose data is to be produced by this Connection Object.
15	Required	consumed_connection_path_length	UINT	Number of bytes in the consumed_connection_path attribute
16	Required	consumed_connection_path	Array of USINT	Specifies the Application Object(s) that are to receive the data consumed by this Connection Object
17	Conditional	production_inhibit_time	UINT	Defines minimum time between new data production. This attribute is required for I/O Client connections

© PHOENIX CONTACT 03/2007