



Chipsmall Limited consists of a professional team with an average of over 10 year of expertise in the distribution of electronic components. Based in Hongkong, we have already established firm and mutual-benefit business relationships with customers from,Europe,America and south Asia,supplying obsolete and hard-to-find components to meet their specific needs.

With the principle of “Quality Parts,Customers Priority,Honest Operation,and Considerate Service”,our business mainly focus on the distribution of electronic components. Line cards we deal with include Microchip,ALPS,ROHM,Xilinx,Pulse,ON,Everlight and Freescale. Main products comprise IC,Modules,Potentiometer,IC Socket,Relay,Connector.Our parts cover such applications as commercial,industrial, and automotives areas.

We are looking forward to setting up business relationship with you and hope to provide you with the best service and solution. Let us make a better world for our industry!



## Contact us

Tel: +86-755-8981 8866 Fax: +86-755-8427 6832

Email & Skype: info@chipsmall.com Web: www.chipsmall.com

Address: A1208, Overseas Decoration Building, #122 Zhenhua RD., Futian, Shenzhen, China



# IB IL 24 PWR IN/2F-DF IB IL 24 PWR IN/2F-DF-PAC

Inline Power Terminal  
With Fuse and Diagnostics

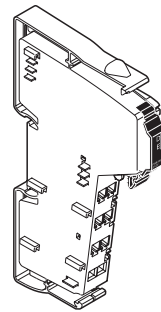

Data Sheet

06/2004

7047A001



The IB IL 24 PWR IN/2F-DF and IB IL 24 PWR IN/2F-DF-PAC only differ in the scope of supply (see "Ordering Data" on page 11). Their function and technical data are identical.

For greater clarity, the Order Designation IB IL 24 PWR IN/2F-DF is used throughout this document.



This data sheet is only valid in association with the IB IL SYS PRO UM E user manual or the Inline system manual for your bus system.

## Function

The terminal is designed for use within an Inline station.

The terminal supplies 24 V supply voltage to the main circuit ( $U_M$ ) and automatically provides the 24 V supply voltage to the segment circuit ( $U_S$ ).

The terminal has protection against polarity reversal and surge voltage.

The internal fuse protects the main and segment circuit.

This terminal has an LED for bus diagnostics and occupies two input data bits, which are used to indicate the presence of the supply voltage and the state of the fuse.

## Features

- Supply of the 24 V main voltage  $U_M$
- Provision of the 24 V segment voltage  $U_S$
- Main and segment circuit protected by an internal fuse
- Diagnostic indicators
- This terminal is an INTERBUS device.

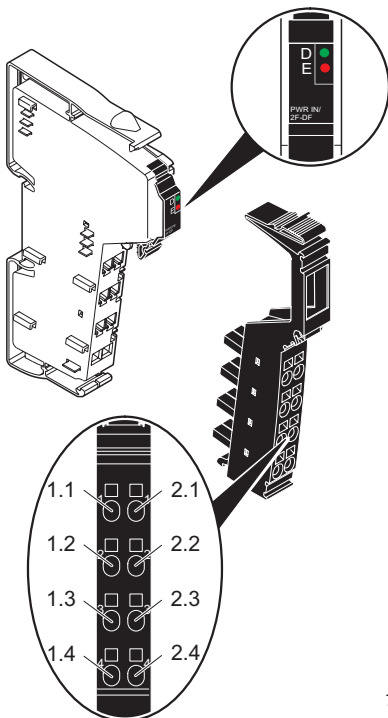

Figure 1 IB IL 24 PWR IN/2F-DF with appropriate connector

**Function Identification**

Black

7047A002

**Local Diagnostic Indicators**

Des.	Color	Meaning
<b>D</b>	<b>Green</b>	<b>Bus Diagnostics</b>
		ON: INTERBUS is active
		Flashing:
		0,5 Hz Communications power present, INTERBUS not active
		2 Hz I/O error, if the fuse is blown or missing.
		4 Hz Communications power present, local bus error
OFF: Communications power not present, INTERBUS not active		
<b>E</b>	<b>Red</b>	<b>Fuse</b>
		OFF: Fuse OK
		ON: Fuse has blown



If the fuse is missing or has blown, an I/O error message is sent to the higher-level control or computer system.



A blown or missing fuse is indicated by both LED diagnostic indicators. The red E LED lights up and the green D LED flashes at 2 Hz.

## Terminal Point Assignment

Terminal Point	Assignment
1.1, 2.1	Measuring points for the segment circuit $U_S$
1.2, 2.2	Supply points for the main circuit $U_M$ (+24 V)  These terminal points are connected with each other and with the potential jumper of the main supply $U_M$ via the fuse. The potential jumpers of the main circuit $U_M$ and the segment circuit $U_S$ (both protected) have a combined current carrying capacity of 6.3 A.
1.3, 2.3	Ground contact (GND) for main and segment circuit  The reference potential is directly routed to the potential jumper and is, at the same time, ground reference for the main and segment voltages.
1.4, 2.4	FE connection  The contacts are directly connected with the potential jumper and the FE springs on the bottom of the housing. The terminal is grounded when it is snapped onto a grounded DIN rail.
	Terminal points 1.2 and 1.3 are connected with a capacitor to FE.

**Observe the current carrying capacity**

The maximum total current flowing through the potential jumpers must not exceed 6.3 A.

## Internal Circuit Diagram

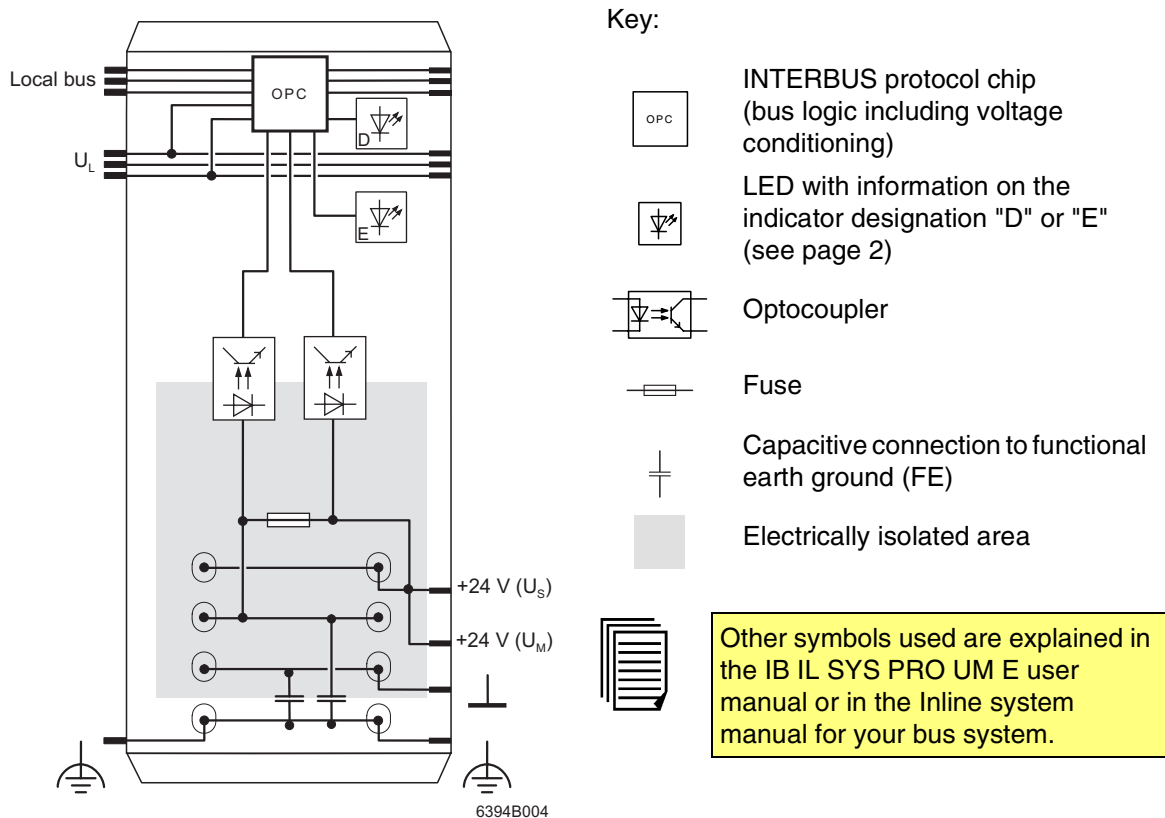

Figure 2 Internal wiring of the terminal points

## Connection Example



The 24 V supply in the main and segment circuit is protected by the internal fuse.



Most I/O terminals are supplied from the segment circuit.

This voltage is automatically provided at the IB IL 24 PWR IN/2F-DF terminal.

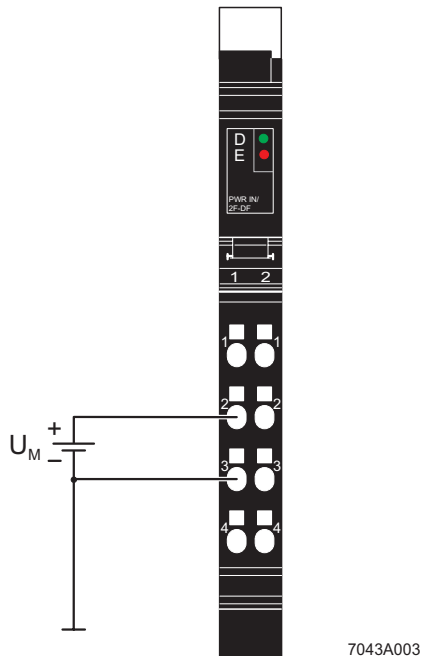

Figure 3 Typical connection of the supply voltage  $U_M$



To ensure maximum current carrying capacity, use a power connector to connect the cables (see page 11). In these connectors, the adjacent terminal points 1.2 and 2.2, and 1.3 and 2.3 are jumpered internally.

## Programming Data/ Configuration Data

### INTERBUS

ID code	BE <sub>hex</sub> (190 <sub>dec</sub> )
Length code	C2 <sub>hex</sub>
Process data channel	2 bits
Input address area	2 bits
Output address area	0 bits
Parameter channel (PCP)	0 bits
Register length (bus)	2 bits

### Other Bus Systems



For the programming data of other bus systems, please refer to the appropriate electronic device data sheet (GSD, EDS). Up-to-date information can be found on the Internet at [www.phoenixcontact.com](http://www.phoenixcontact.com).

## Process Data

### Assignment of the IN Process Data Words





The IN process data only maps the status of the fuse and the main voltage.

(Byte.bit) view		0.1	0.0
Assignment	Main voltage $U_M$ is present, fuse is OK	1	1
	Main power $U_M$ present, fuse blown or missing	1	0
	Main power $U_M$ not present, fuse blown or missing	0	0



For the assignment of the illustrated (byte.bit) view to your control or computer system, please refer to the DB GB IBS SYS ADDRESS data sheet, Order No. 90 00 99 0.

## Technical Data

General Data	
Order Designation	Order No.
	IB IL 24 PWR IN/2F-DF 28 63 78 2 IB IL 24 PWR IN/2F-DF-PAC 28 63 77 9
Housing dimensions (width x height x depth)	12.2 mm x 120 mm x 71.5 mm (0.480 x 4.724 x 2.815 in.)
Weight	44 g (without connectors)
Operating mode	Process data mode with 2 bits
Transmission speed	500 kbps
Permissible temperature (operation)	-25°C to +55°C (-13°F to +131°F)
Permissible temperature (storage/transport)	-25°C to +85°C (-136°F to +185°F)
Permissible humidity (operation)	75% on average, 85% occasionally
	In the range from -25°C to +55°C (-13°F to +131°F) appropriate measures against increased humidity (> 85%) must be taken.
Permissible humidity (storage/transport)	75% on average, 85% occasionally
	For a short period, slight condensation may appear on the outside of the housing if, for example, the terminal is brought into a closed room from a vehicle.
Permissible air pressure (operation)	80 kPa to 106 kPa (up to 2,000 m [6,562 ft.] above sea level)
Permissible air pressure (storage/transport)	70 kPa to 106 kPa (up to 3,000 m [9,843 ft.] above sea level)
Degree of protection	IP20 according to IEC 60529
Class of protection	Class 3 according to VDE 0106, IEC 60536
Interface	
Local bus interface	Through data routing



Power Consumption	
Communications power $U_L$	7.5 V DC
Current consumption at $U_L$	25 mA, maximum
Power consumption at $U_L$	0.19 W, maximum
Main voltage $U_M$	24 V DC (nominal value)
Nominal current consumption at $U_M$	4.0 A (nominal value)

Supply of the Module Electronics Through the Bus Terminal ( $U_L$ )	
Connection method	Through potential routing

24 V I/O Supply (Main Circuit $U_M$ )		
Connection	+24 V Ground (GND)	Terminal points 1.2 and 2.2 Terminal points 1.3 and 2.3
Rated value		24 V DC
Tolerance		-15% / +20%
AC component		5%
Permissible range		19.2 V to 30 V
Permissible current		6.3 A, maximum
Voltage supply requirements		The power terminal must be supplied from a new power supply unit to create an electrically isolated area. Protect the 24 V power supply with an external fuse.
	The power supply unit must be able to supply 4 times (400%) the nominal current of the external fuse.	

Permissible Total Current in the Potential Jumpers of the Main and Segment Circuit/ Nominal Current of the Terminal		
Permissible total current in the potential jumpers	6.3 A	
Nominal current of the terminal	4.0 A	
Tolerance	+10%	
	The terminal is delivered with a 6.3 A slow-blow fuse. With an increased total current in the potential jumpers $U_M$ and $U_S$ the user must protect the circuit by using higher rated fuses. Please note the information for the selection of fuses given on page 8.	

**Power Dissipation**

**Formula to Calculate the Power Dissipation of the Electronics**

$$P_{TOT} = 0.180 \text{ W} + I_M^2 \times R_F$$

Where

$P_{TOT}$  Total power dissipation in the terminal

$I_M$  Load current in the main circuit

$R_F$  Resistance of the fuse

The resistance of fuse  $R_F$  for a 6.3 AT fuse is approximately 12 mΩ.

The power dissipation of the electronics for a theoretical maximum current of 6.3 A (nominal current = 4.0 A) is calculated as follows:

$$\begin{aligned} P_{TOT} &= 0.18 \text{ W} + 39.69 \text{ A}^2 \times 0.012 \text{ } \Omega \\ &= 0.66 \text{ W} \end{aligned}$$

**Power Dissipation of the Housing ( $P_{HOU}$ )**

$P_{HOU} = 0.7 \text{ W}$  in the total permissible ambient temperature range

**Typical Power Dissipation of the Electronics Depending on the Load Current in the Main Circuit**

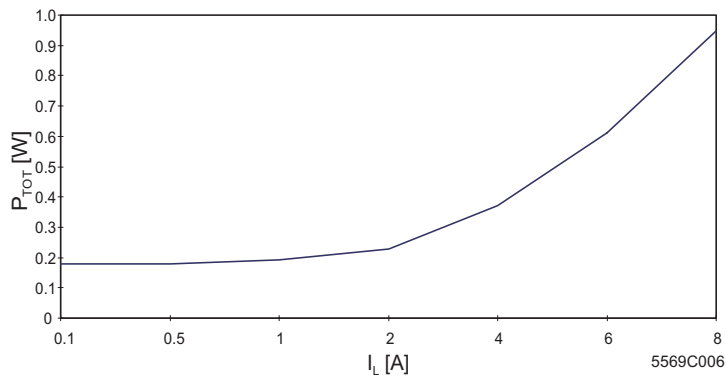





$P$  [W] Power dissipation in W  
 $I_L$  [A] Load current in the main circuit in A

**This test was carried out with a 6.3 AT fuse.**

**Derating of the Load Current in the Segment Circuit**

No derating

<b>Safety Equipment</b>	
Overload/short circuit in the main circuit and in the segment circuit	Fuse 5 x 20 with 6.3 A, slow-blow
	Fuses with other values can also be used. The maximum fuse value may not exceed 6.3 A.
	<b>Note for the selection of fuses:</b> Only use slow-blow fuses for fuses with higher rating than 2 A.
Surge voltage	Yes, suppressor diode for voltage limitation between terminal points 1.1 and 1.3, and terminal points 1.2 and 1.3
Polarity reversal	Yes; diode connected in parallel as protection against polarity reversal
	The power supply unit must be able to supply 4 times (400%) the nominal current of the internal fuse.
<b>Electrical Isolation</b>	
	To provide electrical isolation between the logic level and the I/O area, it is necessary to supply these areas via the bus terminal or via the bus terminal and a power terminal from separate power supply units. Interconnection of the power supply units in the 24 V area is not permitted. Please also pay attention to GND/PE connections on the power supply units (see also user manual).
<b>Common Potentials</b>	
The 24 V main voltage, 24 V segment voltage, and GND have the same potential. FE is a separate potential area.	
<b>Separate Potentials in the System Consisting of Bus Terminal/Power Terminal and I/O Terminal</b>	
- Test Distance	- Test Voltage
5 V supply incoming remote bus / 7.5 V supply (bus logic)	500 V AC, 50 Hz, 1 min.
5 V supply outgoing remote bus / 7.5 V supply (bus logic)	500 V AC, 50 Hz, 1 min.
7.5 V supply (bus logic)/24 V supply (I/O)	500 V AC, 50 Hz, 1 min.
24 V supply (I/O)/functional earth ground	500 V AC, 50 Hz, 1 min.

Error Messages to the Superior Control System
I/O error message if fuse blown or missing

## Ordering Data

Description	Order Designation	Order No.
Power terminal with fuse and diagnostics; including connectors and labeling field	IB IL 24 PWR IN/2F-DF-PAC	28 63 77 9
Power terminal with fuse and diagnostics	IB IL 24 PWR IN/2F-DF	28 63 78 2
 <div style="background-color: yellow; padding: 5px;">                     One of the listed connectors is needed for the complete fitting of the IB IL 24 PWR IN/2F-DF terminal.                 </div>		
Connector for voltage supply (black, with color print); pack of 10	IB IL SCN-PWR IN-CP	27 27 63 7
Connector for voltage supply (black, w/o color print); pack of 10	IB IL SCN-PWR IN	27 27 46 2
Fuse	SI 5 x 20 6,300 A T	50 30 51 2
"Configuring and Installing the INTERBUS Inline Product Range" user manual	IB IL SYS PRO UM E	27 43 04 8



Make sure you always use the latest documentation. It can be downloaded at [www.phoenixcontact.com](http://www.phoenixcontact.com).

Phoenix Contact GmbH & Co. KG  
 Flachsmarktstr. 8  
 32825 Blomberg  
 Germany

 + 49 - (0) 52 35 - 3-00

 + 49 - (0) 52 35 - 3-4 12 00

 [www.phoenixcontact.com](http://www.phoenixcontact.com)

 Worldwide Locations:  
[www.phoenixcontact.com/salesnetwork](http://www.phoenixcontact.com/salesnetwork)