



Chipsmall Limited consists of a professional team with an average of over 10 year of expertise in the distribution of electronic components. Based in Hongkong, we have already established firm and mutual-benefit business relationships with customers from,Europe,America and south Asia,supplying obsolete and hard-to-find components to meet their specific needs.

With the principle of “Quality Parts,Customers Priority,Honest Operation,and Considerate Service”,our business mainly focus on the distribution of electronic components. Line cards we deal with include Microchip,ALPS,ROHM,Xilinx,Pulse,ON,Everlight and Freescale. Main products comprise IC,Modules,Potentiometer,IC Socket,Relay,Connector.Our parts cover such applications as commercial,industrial, and automotives areas.

We are looking forward to setting up business relationship with you and hope to provide you with the best service and solution. Let us make a better world for our industry!



Contact us

Tel: +86-755-8981 8866 Fax: +86-755-8427 6832

Email & Skype: info@chipsmall.com Web: www.chipsmall.com

Address: A1208, Overseas Decoration Building, #122 Zhenhua RD., Futian, Shenzhen, China



MINI MCR-SL-R-UI...

Measuring resistance/potentiometer converter



INTERFACE

Data sheet
102807_en_06

© PHOENIX CONTACT 2010-11-23

1 Description

The 6.2 mm wide MINI MCR-SL-R-UI... potentiometer transducer converts potentiometer positions as a percentage of an standard analog signal. If the potentiometer range cannot be utilized to the full, an externally accessible slide switch is used to set the upper and lower potentiometer end values. The output signal between 0 and 100% is based on this fixed end value.

The DIP switches are accessible on the side of the housing and allow the following parameters to be configured:

- output signal,
- automatic potentiometer detection,
- open circuit detection loop as well as
- error indication type.

Power (19.2 V DC to 30 V DC) can be supplied through connection terminal blocks on the modules or in conjunction with the DIN rail connector.

Features

- Configurable potentiometer transducer
- Output signal range can be configured using a DIP switch
- Approval for Ex-zone 2 (nA)
- Screw or spring-cage connection can be provided



Attention: Correct usage in potentially explosive areas

The module is a category 3 item of electrical equipment. It is absolutely vital to follow the instructions provided here during installation and observe the information in the "Safety regulations and installation notes".



Make sure you always use the latest documentation.

It can be downloaded from the product at www.phoenixcontact.net/catalog.



This data sheet is valid for all products listed on the following page:

2	Table of contents	
1	Description	1
2	Table of contents	2
3	Ordering data	3
4	Technical data	3
5	Safety regulations and installation notes.....	5
	5.1 Installation notes	5
	5.2 Installation in the Ex area (zone 2).....	5
6	Installation	6
	6.1 Connection notes	6
	6.2 Structure	6
	6.3 Block diagram.....	6
	6.4 Power supply.....	6
	6.5 Assembly.....	7
	6.6 Connecting the wires	7
7	Configuration	8
	7.1 Configuration tables	9
8	Diagnostics LED	9
9	Teach-In	10
10	Connection/application example	10

3 Ordering data

Description	Type	Order No.	Pcs./Pkt.
MCR potiposition transducer for conversion of potentiometer positions into a standard analog signal, 0 Ω input... 100 Ω to 0 kΩ ... 100 kΩ	MINI MCR-SL-R-UI	2864095	1
MCR potiposition transducer for converting potentiometer positions to an analog standard signal, input 0...100 Ω to 0...100 kΩ	MINI MCR-SL-R-UI-SP	2810256	1
Accessories	Type	Order No.	Pcs./Pkt.
DIN rail connector (TBUS), 5-pos., for bridging the supply voltage, can be snapped onto NS 35/... DIN rails according to EN 60715	ME 6,2 TBUS-2 1,5/5-ST-3,81 GN	2869728	10
MCR power terminal block for supplying several MINI Analog modules via the DIN rail connectors, with screw connection, current consumption up to max. 2 A	MINI MCR-SL-PTB	2864134	1
MCR power terminal block for supplying several MINI-ANALOG modules via the DIN rail connectors, with spring-cage connection, current consumption up to max. 2 A	MINI MCR-SL-PTB-SP	2864147	1
DIN rail power supply unit, primary-switched mode, slim design, output: 24 V DC / 1.5 A	MINI-SYS-PS-100-240AC/24DC/1.5	2866983	1
DIN rail power supply unit, primary-switched mode, slim design, output: 24 V DC / 1.5 A, ATEX approval	MINI-PS-100-240AC/24DC/1.5/EX	2866653	1
Eight MINI analog signal converters with screw connection method can be connected to a control system using a system adapter and system cabling with a minimum of wiring and very low error risk.	MINI MCR-SL-V8-FLK 16-A	2811268	1
Fold up transparent cover for MINI MCR modules with additional labeling option using insert strips and flat Zack marker strip 6.2 mm	MINI MCR DKL	2308111	10
Label for extended marking of MINI MCR modules in connection with the MINI MCR-DKL	MINI MCR-DKL-LABEL	2810272	10

4 Technical data

Input	
Potentiometer resistance range	100 Ω ... 100 kΩ
Reference voltage source	< 3.6 V
Output	
Voltage output signal	0 V ... 5 V 0 V ... 10 V 1 V ... 5 V 10 V ... 0 V
Max. voltage output signal	12.5 V
Non-load voltage	Approx. 12.5 V
Current output signal	0 mA ... 20 mA 4 mA ... 20 mA 20 mA ... 0 mA 20 mA ... 4 mA
Max. current output signal	23 mA
Short-circuit current	Approx. 10 mA
Load/output load voltage output	> 10 kΩ
Ripple	< 20 mV _{PP} (at 500 Ω)
Load/output load current output	< 500 Ω (20 mA)
Behavior in the event of a sensor error	Configurable 0 % ... 105 %

Supply

Nominal supply voltage	24 V DC
Supply voltage range	19.2 V DC ... 30 V DC (to bridge the supply voltage, the DIN rail connector (ME 6,2 TBUS-2 1,5/5-ST-3,81 GN, Order No. 2869728) can be used. It can be snapped onto a 35 mm DIN rail according to EN 60715)
Typical current consumption	< 25 mA (at 24 V DC)
Power consumption	< 500 mW

General data

Maximum transmission error	< 0.2 %
Maximum temperature coefficient	< 0.02 %/K
Step response (10-90%)	< 30 ms
Electrical isolation	Basic insulation according to EN 61010
Surge voltage category	II
Mounting position	Any
Degree of protection	IP20
Pollution degree	2
Rated insulation voltage	50 V AC/DC
Test voltage, input/output/supply	1.5 kV (50 Hz, 1 min.)
Dimensions W / H / D	6.2 mm / 93.1 mm /
Type of housing	PBT green

Connection data**Screw connection****Spring-cage conn.**

Conductor cross section, solid	0.14 mm ² ... 2.5 mm ²	0.2 mm ² ... 2.5 mm ²
Conductor cross section, stranded	0.2 mm ² ... 2.5 mm ²	0.2 mm ² ... 2.5 mm ²
Stripping length	12 mm	8 mm

Ambient conditions

Ambient temperature (operation)	-20 °C ... 65 °C
Ambient temperature (storage/transport)	-40 °C ... 85 °C

Conformance with EMC Directive 2004/108/EC

Noise immunity according to EN 61000-6-2
Noise emission according to EN 61000-6-4

Conformance / approvals

Conformance	CE-compliant
ATEX	⊕ II 3 G Ex nA II T4 X
UL, USA / Canada	UL 508 Recognized
UL, USA / Canada	Class I, Div. 2, Groups A, B, C, D T5 applied for
Shipbuilding	GL EMC 2 D

5 Safety regulations and installation notes

5.1 Installation notes

- The device is designed for installation in zone 2 potentially explosive areas.
- Installation, operation, and maintenance may only be carried out by qualified electricians. Follow the installation instructions described. When installing and operating the device, the applicable regulations and safety directives (including national safety directives), as well as general technical regulations, must be observed. The technical data is provided in this package slip and on the certificates (conformity assessment, additional approvals where applicable).
- It is not permissible to open or modify the device. Do not repair the device yourself but replace it with an equivalent device. Repairs may only be carried out by the manufacturer. The manufacturer is not liable for damage resulting from violation.
- The IP20 degree of protection (EN 60529) of the device is intended for use in a clean and dry environment. Do not subject the device to any load that exceeds the described limits.
- The device is not designed for use in atmospheres with a danger of dust explosions.

5.2 Installation in the Ex area (zone 2)

- Observe the specified conditions for use in potentially explosive areas.
- The device must be installed in a housing (control or distributor box) which meets the requirements of EN 60079-15 and provides at least IP54 (EN 60529) degree of protection.
- During installation and when connecting the supply and signal circuits, observe the requirements of EN 60079-14. Devices may only be connected to circuits in zone 2 if they are suitable for operation in Ex zone 2 and for the prevailing conditions at the place of use.
- In potentially explosive areas, terminals may only be snapped onto or off the DIN rail connector and wires may only be connected or disconnected when the power is switched off.
- The device must be stopped and immediately removed from the Ex area if it is damaged, has been subjected to an impermissible load, has been stored incorrectly, or if it malfunctions.
- You can download the latest documents for these devices from www.phoenixcontact.net/catalog.

6 Installation

6.1 Connection notes



Attention: Electrostatic discharge!

The device contains components that can be damaged or destroyed by electrostatic discharge. When handling the device, observe the necessary safety precautions against electrostatic discharge (ESD) according to EN 61340-5-1 and EN 61340-5-2.

6.2 Structure

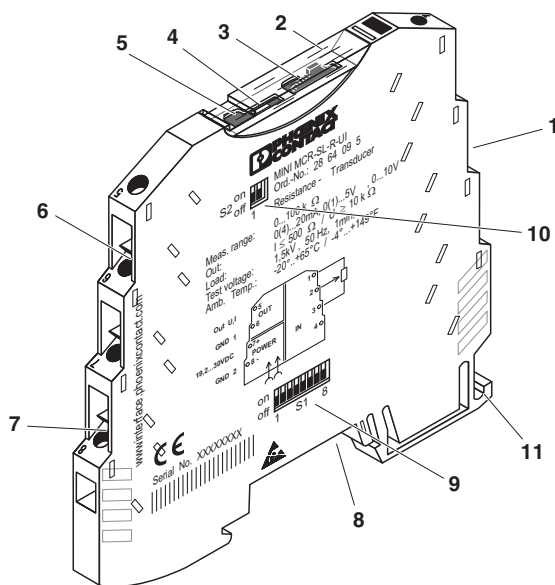

Figure 1 Structure

1. Input: potentiometer
2. Cover
3. Press/Slide button for Teach-In
4. Diagnostics LED
5. Groove for ZBF 6 zack marker strip
6. Output: Standard signals
7. Supply voltage
8. Connection option for DIN rail connector
9. DIP switch S1
10. DIP switch S2
11. Universal snap-on foot for EN DIN rails

6.3 Block diagram

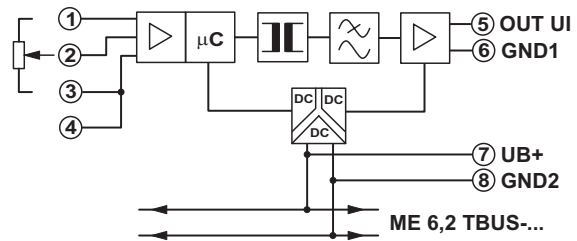

Figure 2 Block diagram

6.4 Power supply



ATTENTION:

Never connect the supply voltage directly to the DIN rail connector. It is not permitted to draw power from the DIN rail connector or from individual modules.

Supply via the MINI Analog Module

Where the total current consumption of the aligned modules does not exceed 400 mA, the power can be supplied directly at the connection terminal blocks of the module.

A 400 mA fuse should be connected upstream.

Supply via a power terminal block

The MINI MCR-SL-PTB power terminal block (Order No. 2864134) or the MINI MCR-SL-PTB-SP power terminal block (Order No. 2864147), which are the same shape, are used to feed the supply voltage to the DIN rail connector.

A 2 A fuse should be connected upstream.

Supply via a system power supply unit

The system power supply unit with 1.5 A output current connects the DIN rail connector to the supply voltage and can therefore be used to supply several modules from the mains.

- MINI-SYS-PS-100-240AC/24DC/1.5 (Order No. 2866983)
- Potentially explosive areas:
MINI-PS-100-240AC/24DC/1.5/EX (Order No. 2866653)

6.5 Assembly

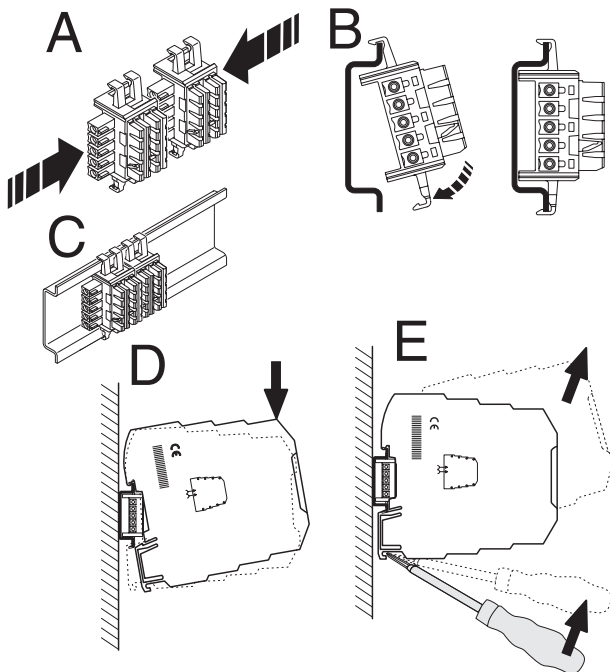

Figure 3 Mounting and removing

- Mount the module on a 35 mm DIN rail according to EN 60715.
- When using the DIN rail connector, first place it into the DIN rail (see A – C). It is used to bridge the power supply. It is also absolutely vital that you snap the module and the DIN rail connector into position in the correct direction: the snap-on foot should be at the bottom and the connector on the left.

6.6 Connecting the wires

The MINI MCR-SL-R-UI... is available in two connection variants:

- Screw terminal blocks (MINI MCR-SL-R-UI)
- Spring-cage terminal blocks (MINI-MCR-SL-R-UI-SP)

Screw connection:

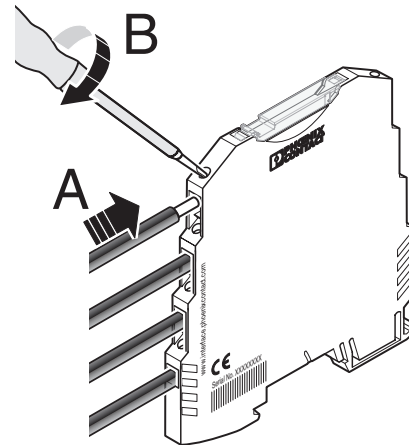

Figure 4 Screw connection

- Insert the wire into the corresponding connection terminal block.
- Use a screwdriver to tighten the screw in the opening above the connection terminal block.

Spring-cage connection:

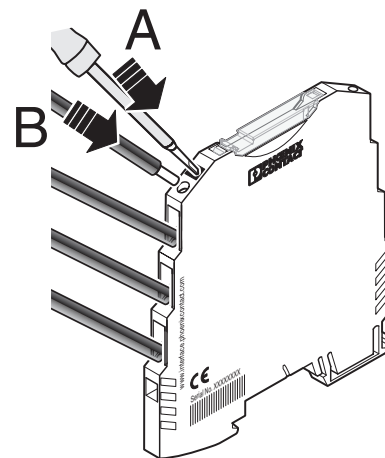

Figure 5 Spring-cage connection

- Insert a screwdriver into the opening above the connection terminal block.
- Insert the wire into the corresponding connection terminal block.

7 Configuration

If the modules are not configured (all DIP switches set to position 0), the module does not have a defined function until the DIP switches have been set.

The output signal range, potentiometer/open circuit detection and fault evaluation is specified by the SP1 DIP switch.

Activate automatic potentiometer detection to obtain optimum measurement results.

You can use the S2 DIP switch to select the voltage and current output.

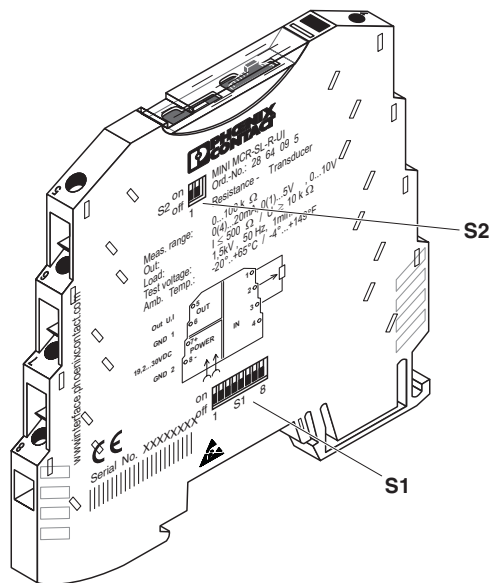

Figure 6 Location of the DIP switches

7.1 Configuration tables

DIP S1	1	2	3	Output signal range OUT	4	Automatic potentiometer detection	5	Open circuit detection slider	6	Transmission Behavior
					0...20 mA		on		on	Fault evaluation in acc. with DIP 1 (7+8)
	•				20...0 mA	•	off	•	off	Output in acc. with NE 43 Open circuit 0 mA (0 V)
		•			4...20 mA					• Linear behavior 3.8 mA ... 20.5 mA (0.95 V ... 5.12 V)
	•	•			20...4 mA					Only active for 4...20 mA (1...5 V) OUT
			•		0...10 V					
	•	•			10...0 V					
	•	•	•		0...5 V					
			1...5 V							

7	8	Open circuit	Measuring range overrange	Measuring range underrange
A		End of measuring range +5 %	End of measuring range +2.5 %	Start of measuring range
B	•	End of measuring range +5 %	End of measuring range +2.5 %	Start of measuring range -12.5 %
C	•	End of measuring range +5 %	End of measuring range	Start of measuring range
D	•	Start of measuring range	End of measuring range	Start of measuring range

DIP S2	1	2	Output signal OUT	
	•		0...20 mA, 4...20 mA, 20...0 mA, 20...4 mA	
		•	0...10 V, 10...0 V, 0...5 V, 1...5 V	• <input type="checkbox"/> ON
	•	•	Not allowed!	<input type="checkbox"/> OFF

8 Diagnostics LED

The LED indicates the following error states:

- LED ON: In the event of a wire break on the sensor side, measured value overrange or measured value under-range

9 Teach-In

The "Teach-In" function serves to adjust the potentiometer range if it is not possible to use the entire range even though the output signal is to be fully used. The press/slide button located under the transparent cover is used for making the settings.

Setting to the lower Teach-In value

Set the potentiometer to the lowest Teach-In value and press the button downwards for approx. 1 second (towards terminal 1). If the value is saved successfully, the LED flashes once.

Setting to the upper Teach-In value

Set the potentiometer to the highest Teach-In value and press the button upwards for approx. 1 second (towards terminal 5). If the value is saved successfully, the LED flashes once.

Resetting to the lower potentiometer value

If the button is pressed downwards for more than 3 seconds (towards terminal 1), the lower Teach-In value is reset to the lower potentiometer value. After successful deletion of the the values, the LED flashes twice.

If the button is pressed for longer that 3 seconds, both Teach-In values are reset and the full potentiometer range (0 % to 100 %) is used.

Resetting to the upper potentiometer value

If the button is pressed upwards for more than 3 seconds (direction of terminal 5), the upper Teach-In value is reset to the upper potentiometer value. After successful deletion of the the values, the LED flashes twice.

If the button is pressed for longer that 3 seconds, both Teach-In values are reset and the full potentiometer range (0 % to 100 %) is used.

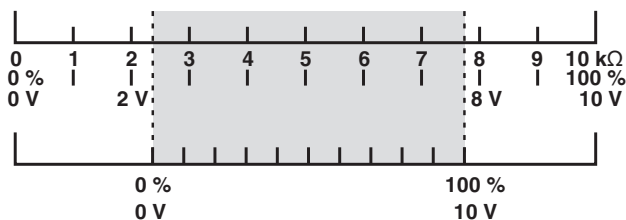

Figure 7 Example, determining the potentiometer range

10 Connection/application example

Positioning table with positioner/controller

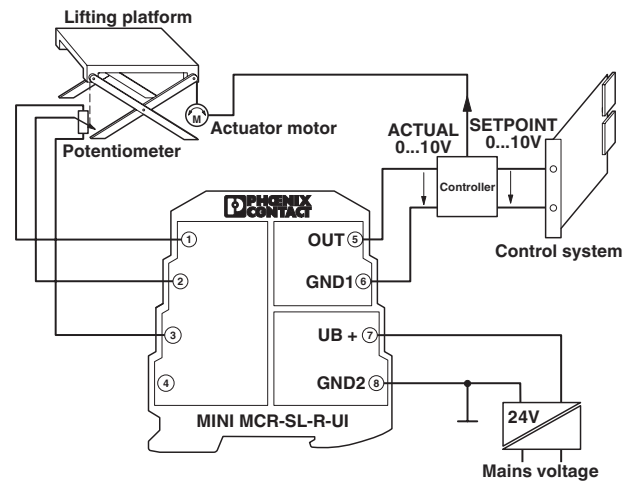

Figure 8 Connection example