



Chipsmall Limited consists of a professional team with an average of over 10 year of expertise in the distribution of electronic components. Based in Hongkong, we have already established firm and mutual-benefit business relationships with customers from,Europe,America and south Asia,supplying obsolete and hard-to-find components to meet their specific needs.

With the principle of “Quality Parts,Customers Priority,Honest Operation,and Considerate Service”,our business mainly focus on the distribution of electronic components. Line cards we deal with include Microchip,ALPS,ROHM,Xilinx,Pulse,ON,Everlight and Freescale. Main products comprise IC,Modules,Potentiometer,IC Socket,Relay,Connector.Our parts cover such applications as commercial,industrial, and automotives areas.

We are looking forward to setting up business relationship with you and hope to provide you with the best service and solution. Let us make a better world for our industry!



Contact us

Tel: +86-755-8981 8866 Fax: +86-755-8427 6832

Email & Skype: info@chipsmall.com Web: www.chipsmall.com

Address: A1208, Overseas Decoration Building, #122 Zhenhua RD., Futian, Shenzhen, China



MINI MCR-SL-PT100-UI-200

Configurable temperature transducer for PT100

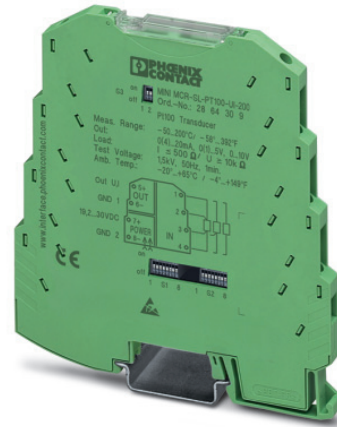

Data sheet
102478_en_03

© PHOENIX CONTACT 2012-04-24

1 Description

The MINI MCR-SL-PT100-UI-200... is a configurable 3-way isolated temperature transducer. It is suitable for the connection of PT100 resistance thermometers according to IEC 60751 in 2-, 3-, and 4-wire connection methods. The measuring range can be configured from -50°C to +200°C using a DIP switch.

The standard analog signals 0...20 mA, 4...20 mA, 0...10 V, 0...5 V, 1...5 V, 10...0 V, 20...0 mA, 20...4 mA are available electrically isolated on the output side.

The DIP switches are accessible on the side of the housing and allow the following parameters to be configured:

- Connection method
- Temperature range to be measured
- Output signal
- Type of fault evaluation

The power supply (19.2...30 V DC) can be supplied either via connection terminal blocks "7"/"8" on the modules or in conjunction with the DIN rail connector. Please refer to the section titled "Connection methods" for more information.

Features

- Configurable 3-way temperature transducer
- 2-, 3-, 4-conductor connection method for Pt 100 resistance thermometer
- Measuring range 0°C to 200°C
- Increased accuracy due to smaller temperature measuring range
- Output signal range 0...20 mA, 4...20 mA, 0...10 V, 0...5 V, 1...5 V, 10...0 V, 20...0 mA or 20...4 mA
- Approval for Ex-zone 2 (nA)
- Screw or spring-cage connection can be provided
- Can be supplied configured to order or unconfigured



Attention: Correct usage in potentially explosive areas

The module is a category 3 item of electrical equipment. It is absolutely vital to follow the instructions provided here during installation and observe the information in the "Safety regulations and installation notes".



Make sure you always use the latest documentation.
It can be downloaded from the product at www.phoenixcontact.net/catalog.



This data sheet is valid for all products listed on the following page:

2	Table of contents	
1	Description	1
2	Table of contents	2
3	Ordering data	3
3.1	Order key	3
4	Technical data	4
5	Safety regulations and installation notes.....	6
5.1	Installation notes	6
5.2	Installation in the Ex area (zone 2).....	6
6	Installation	7
6.1	Connection notes	7
6.2	Structure	7
6.3	Block diagram.....	7
6.4	Power supply.....	7
6.5	Assembly.....	8
6.6	Connecting the wires	8
7	Configuration	9
7.1	Configuration table.....	10
8	Diagnostics LED	11
9	Connection/application example	11

3 Ordering data

Description	Type	Order No.	Pcs. / Pkt.
MCR temperature transducer, can be configured, for Pt 100 temperature sensors, with screw connection, order configuration	MINI MCR-SL-PT100-UI-200	2864309	1
MCR temperature transducer, can be configured, for Pt 100 temperature sensors, with spring-cage connection, order configuration	MINI MCR-SL-PT100-UI-200-SP	2864192	1
MCR temperature transducer, configurable, for Pt 100 temperature sensors, with screw-connection, not configured	MINI MCR-SL-PT100-UI-200-NC	2864370	1
MCR temperature transducer, configurable, for Pt 100 temperature sensors, with spring-cage connection, not configured	MINI MCR-SL-PT100-UI-200-SP-NC	2864202	1

Accessories	Type	Order No.	Pcs. / Pkt.
DIN rail connector (TBUS), 5-pos., for bridging the supply voltage, can be snapped onto NS 35/... DIN rails according to EN 60715	ME 6,2 TBUS-2 1,5/5-ST-3,81 GN	2869728	10
MCR power terminal block for supplying several MINI Analog modules via the DIN rail connectors, with screw connection, current consumption up to max. 2 A	MINI MCR-SL-PTB	2864134	1
MCR power terminal block for supplying several MINI-ANALOG modules via the DIN rail connectors, with spring-cage connection, current consumption up to max. 2 A	MINI MCR-SL-PTB-SP	2864147	1
DIN rail power supply unit, primary-switched mode, slim design, output: 24 V DC / 1.5 A	MINI-SYS-PS-100-240AC/24DC/1.5	2866983	1
DIN rail power supply unit, primary-switched mode, slim design, output: 24 V DC / 1.5 A, ATEX approval	MINI-PS-100-240AC/24DC/1.5/EX	2866653	1
Eight MINI analog signal converters with screw connection method can be connected to a control system using a system adapter and system cabling with a minimum of wiring and very low error risk.	MINI MCR-SL-V8-FLK 16-A	2811268	1
Fold up transparent cover for MINI MCR modules with additional labeling option using insert strips and flat Zack marker strip 6.2 mm	MINI MCR DKL	2308111	10
Label for extended marking of MINI MCR modules in connection with the MINI MCR-DKL	MINI MCR-DKL-LABEL	2810272	10

3.1 Order key

(standard configuration entered as example)

Order No.	Connection method	Measuring range [°C]		Output	Failure information ¹⁾	Factory calibration certificate
		Start	Finish			
2864309	3	0	100	OUT01	A	NONE
2864309 ≙ ...-PT100-UI-200	2 ≙ 2-wire 3 ≙ 3-wire 4 ≙ 4-wire	0 -5 -10 -15 -20 -30 -40 -50	Range (increment) 0 ... 200 (5 K)	OUT01 ≙ 0 ... 20 mA OUT02 ≙ 4 ... 20 mA OUT03 ≙ 0 ... 10 V OUT05 ≙ 0 ... 5 V OUT06 ≙ 1 ... 5 V OUT07 ≙ 20 ... 0 mA OUT08 ≙ 20 ... 4 mA OUT09 ≙ 10 ... 0 V	A B C D	NONE ≙ Without factory calibration YES ≙ With factory calibration certificate (a fee is charged) YESPLUS ≙ Factory calibration certificate with 5 measuring points (a fee is charged)
2864736 ≙ ...-PT100-UI-200-SP						

¹⁾ Failure information:

Measuring range overrange			Cable break			
0 ... 20 mA	4 ... 20 mA	0 ... 10 V	0 ... 20 mA	4 ... 20 mA	0 ... 10 V	
A	20.5 mA	20.5 mA	10.25 V	21 mA	21 mA	10.5 V
B	20.5 mA	20.5 mA	10.25 V	21 mA	21 mA	10.5 V
C	20 mA	20 mA	10 V	21 mA	21 mA	10.5 V
D	20 mA	20 mA	10 V	0 mA	4 mA	0 V

Measuring range underrange			Short circuit			
0 ... 20 mA	4 ... 20 mA	0 ... 10 V	0 ... 20 mA	4 ... 20 mA	0 ... 10 V	
A	0 mA	4 mA	0 V	0 mA	4 mA	0 V
B	0 mA	3.5 mA	0 V	0 mA	3 mA	0 V
C	0 mA	4 mA	0 V	21 mA	21 mA	10.5 V
D	0 mA	4 mA	0 V	0 mA	4 mA	0 V

4 Technical data

Input

Sensor type	Pt 100 (IEC 60751/EN 60751)
Sensor input current	1 mA (constant)
Max. permissible overall conductor resistance	10 Ω (Per cable)
Temperature measuring range	-50 °C ... 200 °C
Measuring range span	min. 50 K
Connection method	2, 3, 4-wire

Output

Voltage output signal	0 V ... 10 V 10 V ... 0 V 0 V ... 5 V 1 V ... 5 V
Max. voltage output signal	Approx. 12.5 V
Non-load voltage	Approx. 12.5 V
Current output signal	0 mA ... 20 mA 4 mA ... 20 mA 20 mA ... 0 mA 20 mA ... 4 mA
Max. current output signal	23 mA
Short-circuit current	Approx. 10 mA
Load/output load voltage output	> 10 k Ω
Ripple	< 20 mV _{pp} (at 500 Ω)
Load/output load current output	< 500 Ω (at 20 mA)

Supply

Nominal supply voltage	24 V DC
Supply voltage range	19.2 V DC ... 30 V DC (to bridge the supply voltage, the DIN rail connector (ME 6,2 TBUS-2 1,5/5-ST-3,81 GN, Order No. 2869728) can be used. It can be snapped onto a 35 mm DIN rail according to EN 60715)
Max. current consumption	< 21 mA (at 24 V DC)
Power consumption	< 500 mW

General data

Transmission error in the set measuring range	((50 K / Δ Temp)+ 0.05)%
Transmission error in the full measuring range	\leq 0,25 %
Maximum temperature coefficient	< 0.02 %/K
Step response (0–99%)	< 200 ms
Electrical isolation	Basic insulation according to EN 61010
Surge voltage category	II
Mounting position	Any
Degree of protection	IP20
Pollution degree	2
Rated insulation voltage	50 V AC/DC
Test voltage, input/output/supply	1.5 kV (50 Hz, 1 min.)
Dimensions W / H / D	6.2 mm / 93.1 mm / 102.5 mm
Type of housing	PBT green

Connection data	Screw connection	Spring-cage conn.
Conductor cross section, solid	0.2 mm ² ... 2.5 mm ²	0.2 mm ² ... 2.5 mm ²
Conductor cross section, stranded	0.2 mm ² ... 2.5 mm ²	0.2 mm ² ... 2.5 mm ²
Stripping length	12 mm	8 mm

Ambient conditions	
Ambient temperature (operation)	-20 °C ... 65 °C
Ambient temperature (storage/transport)	-40 °C ... 85 °C
Permissible humidity (operation)	10 % ... 95 % (no condensation)

Conformance with EMC Directive 2004/108/EC	
Noise immunity according to EN 61000-6-2	
Noise emission according to EN 61000-6-4	

Conformance / approvals	
Conformance	CE-compliant
ATEX	⊕ II 3 G Ex nA IIC T4 Gc X
UL, USA / Canada	UL 508 Recognized
UL, USA / Canada	Class I, Div. 2, Groups A, B, C, D T5
Shipbuilding	GL EMC 2 D

5 Safety regulations and installation notes

5.1 Installation notes

- The category 3 device is suitable for installation in the zone 2 potentially explosive area. It fulfills the requirements of EN 60079-0:2009 and EN 60079-15:2010.
- Installation, operation, and maintenance may only be carried out by qualified electricians. Follow the installation instructions described. When installing and operating the device, the applicable regulations and safety directives (including national safety directives), as well as general technical regulations, must be observed. The technical data is provided in this package slip and on the certificates (conformity assessment, additional approvals where applicable).
- It is not permissible to open or modify the device. Do not repair the device yourself but replace it with an equivalent device. Repairs may only be carried out by the manufacturer. The manufacturer is not liable for damage resulting from violation.
- The IP20 degree of protection (IEC 60529/EN 60529) of the device is intended for use in a clean and dry environment. Do not subject the device to any load that exceeds the described limits.
- The device is not designed for use in atmospheres with a danger of dust explosions.

5.2 Installation in the Ex area (zone 2)

- Observe the specified conditions for use in potentially explosive areas.
- The device must be installed in a housing (control or distributor box) which meets the requirements of EN 60079-15 and provides at least IP54 (EN 60529) degree of protection.
- During installation and when connecting the supply and signal circuits, observe the requirements of EN 60079-14. Devices may only be connected to circuits in zone 2 if they are suitable for operation in Ex zone 2 and for the prevailing conditions at the place of use.
- In potentially explosive areas, terminals may only be snapped onto or off the DIN rail connector and wires may only be connected or disconnected when the power is switched off.
- The device must be stopped and immediately removed from the Ex area if it is damaged, has been subjected to an impermissible load, has been stored incorrectly, or if it malfunctions.
- You can download the latest documents for these devices from www.phoenixcontact.net/catalog.

6 Installation

6.1 Connection notes



Attention: Electrostatic discharge!

The device contains components that can be damaged or destroyed by electrostatic discharge. When handling the device, observe the necessary safety precautions against electrostatic discharge (ESD) according to EN 61340-5-1 and EN 61340-5-2.

6.2 Structure

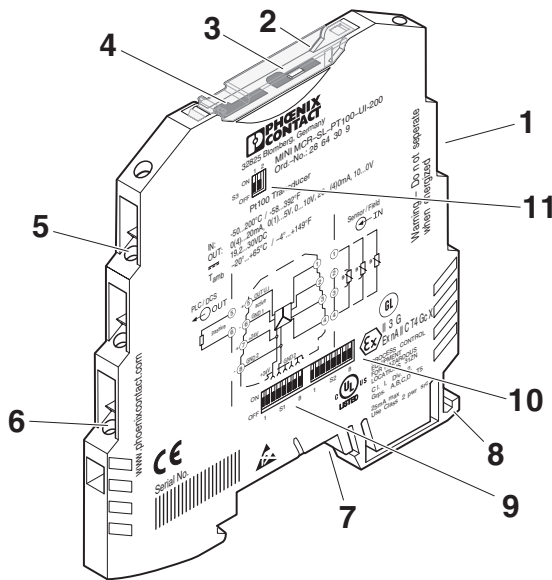

Figure 1 Structure

1. Input: PT100 resistance thermometer
2. Cover
3. Diagnostics LED
4. Groove for ZBF 6 zack marker strip
5. Output: Standard signals
6. Supply voltage
7. Connection option for DIN rail connector
8. Universal snap-on foot for EN DIN rails
9. DIP switch S1
10. DIP switch S2
11. DIP switch S3

6.3 Block diagram

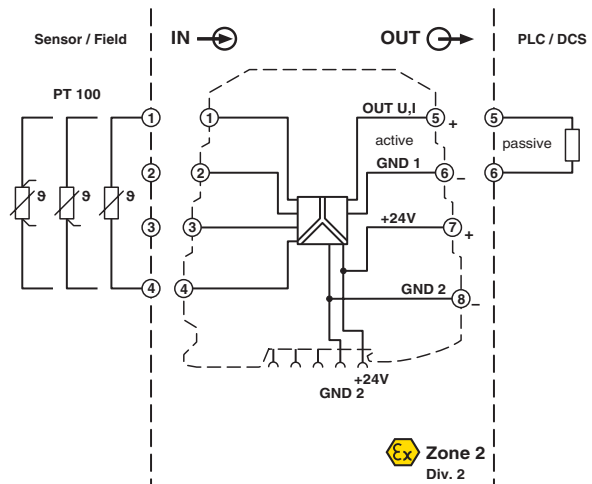

Figure 2 Block diagram

6.4 Power supply



ATTENTION:

Never connect the supply voltage directly to the DIN rail connector. It is not permitted to draw power from the DIN rail connector or from individual modules.

Supply via the module

Where the total current consumption of the aligned modules does not exceed 400 mA, the power can be supplied directly at the connection terminal blocks of the module.

A 400 mA fuse should be connected upstream.

Supply via a power terminal block

The MINI MCR-SL-PTB power terminal block (Order No. 2864134) or the MINI MCR-SL-PTB-SP power terminal block (Order No. 2864147), which are the same shape, are used to feed the supply voltage to the DIN rail connector.

A 2 A fuse should be connected upstream.

Supply via a system power supply unit

The system power supply unit with 1.5 A output current connects the DIN rail connector to the supply voltage and can therefore be used to supply several modules from the mains.

- MINI-SYS-PS-100-240AC/24DC/1.5 (Order No. 2866983)
- Potentially explosive areas:
MINI-PS-100-240AC/24DC/1.5/EX (Order No. 2866653)

6.5 Assembly

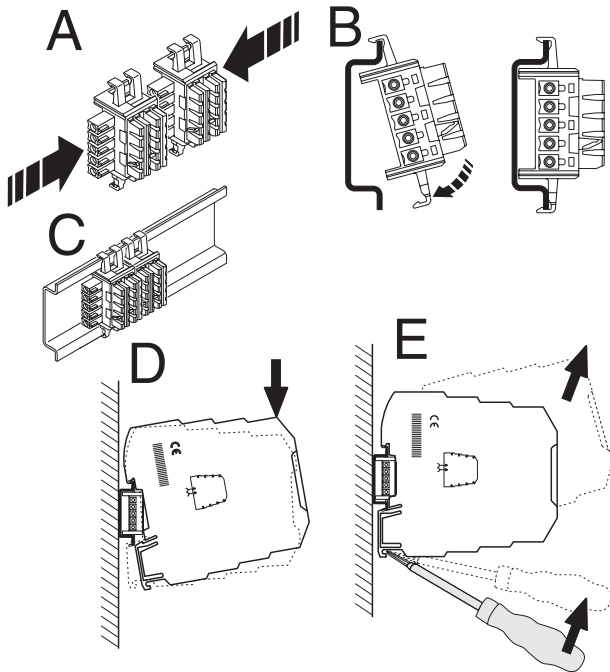

Figure 3 Mounting and removing

- Mount the module on a 35 mm DIN rail according to EN 60715.
- When using the DIN rail connector, first place it into the DIN rail (see A – C). It is used to bridge the power supply. It is also absolutely vital that you snap the module and the DIN rail connector into position in the correct direction: the snap-on foot should be at the bottom and the connector on the left.

6.6 Connecting the wires

The MINI MCR-SL-PT100-UI-200... is available with two types of connection:

- Screw terminal blocks (MINI MCR-SL-PT100-UI-200)
- Spring-cage terminal blocks (MINI MCR-SL-PT100-UI-200-SP)

Screw connection:

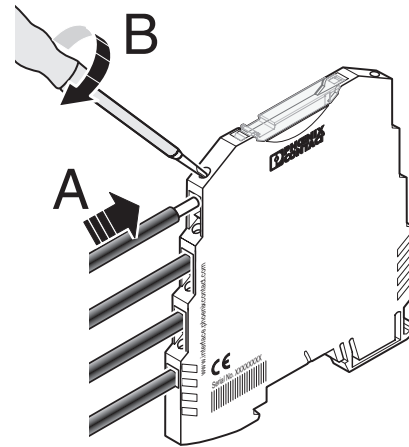

Figure 4 Screw connection

- Insert the wire into the corresponding connection terminal block.
- Use a screwdriver to tighten the screw in the opening above the connection terminal block.

Spring-cage connection:

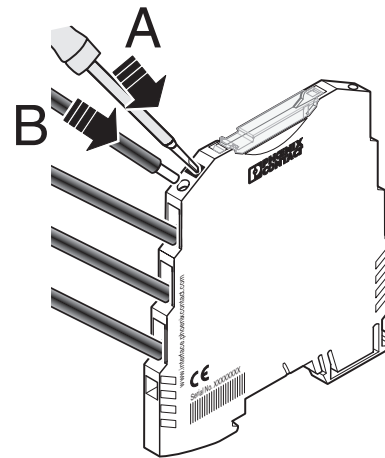

Figure 5 Spring-cage connection

- Insert a screwdriver into the opening above the connection terminal block.
- Insert the wire into the corresponding connection terminal block.

7 Configuration

NC version

If a device has not been configured ("NC type": MINI MCR-SL-PT100-UI-200-NC or MINI MCR-SL-PT100-UI-200-SP-NC), all DIP switches will be set to position 0. The device only has a defined function once the DIP switches have been set.

DIP switch S1

DIP switch S1 is used to specify the connection method, the output signal range, and the measuring range start value.

DIP switch S2

DIP switch S2 is used to specify the measuring range final value and fault evaluation.

DIP switch S3

DIP switch S2 can be used to select the voltage and current output.

7.1 Configuration table

DIP S1		Connection method		Output signal range OUT			Start temperature			
1	2	3	4	5	6	7	8	[°C]	[°F]	
								0	32	
•								-5	23	
	•							-10	14	
•	•							-15	5	
				•				-20	-4	
				•	•			-30	-22	
				•	•	•		-40	-40	
				•	•	•		-50	-58	
								0 ... 20 mA		
								20 ... 0 mA		
								4 ... 20 mA		
								20 ... 4 mA		
								0 ... 10 V		
								10 ... 0 V		
								0 ... 5 V		
								1 ... 5 V		

DIP S2						Final temperature	
1	2	3	4	5	6	[°C]	[°F]
						0	32
•						5	41
	•					10	50
•	•					15	59
		•				20	68
•	•	•				25	77
		•	•			30	86
•	•	•	•			35	95
			•			40	104
•		•				45	113
	•	•				50	122
•	•	•				55	131
		•	•			60	140
•	•	•	•			65	149
		•	•	•		70	158
•	•	•	•			75	167
			•			80	176
•			•			85	185
	•		•			90	194
•	•		•			95	203
		•	•			100	212
•	•	•	•			105	221
		•	•	•		110	230
•	•	•	•			115	239
		•	•	•		120	248
•	•	•	•			125	257
		•	•	•		130	266
•	•	•	•			135	275
		•	•	•		140	284
•	•	•	•			145	293
		•	•	•		150	302
•	•	•	•			155	311
			•			160	320
•			•			165	329
	•					170	338
•	•					175	347
		•				180	356
•	•	•				185	365
		•	•			190	374
•	•	•				195	383
		•	•	•		200	392

DIP S2		7	8	Cable break	Measuring range overrange	Measuring range underrange	Short circuit
A				Measuring range final value +5%	Measuring range final value +2.5%	Measuring range start value	Measuring range start value
B	•			Measuring range final value +5%	Measuring range final value +2.5%	Measuring range start value -12.5%	Measuring range start value -25%
C		•		Measuring range final value +5%	Measuring range final value	Measuring range start value	Measuring range final value +5%
D	•	•		Measuring range start value	Measuring range final value	Measuring range start value	Measuring range start value

DIP S3		1	2	OUT
•				0 ... 20 mA, 4 ... 20 mA, 20 ... 0 mA, 20 ... 4 mA
	•			0 ... 10 V, 10 ... 0 V, 0 ... 5 V, 1 ... 5 V

- ≙ ON
- ≙ OFF

8 Diagnostics LED

The LED which is visible on the front displays the following faults:

- LED flashing: Measuring range span less than 50 K
- LED ON: Open circuit on the sensor side
- LED ON: Short-circuit on the sensor side
- LED ON: Measuring range overrange
- LED ON: Measuring range underrange

9 Connection/application example

2-wire connection method

- For short distances (< 10 m)
- Cable resistances $RL1$ and $RL2$ are incorporated in the measurement result directly and falsify the result accordingly.

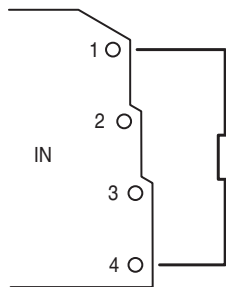

Figure 6 2-wire connection

4-wire connection method

- For longer distances between PT100 sensor and MINI analog module and differing cable resistances ($RL1 \neq RL2 \neq RL3 \neq RL4$).

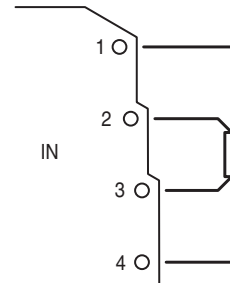

Figure 8 4-wire connection

3-wire connection method

- For long distances between PT100 sensor and MINI analog module
- The value of all cable resistances must be exactly the same ($RL1 = RL2 = RL3$) in order to balance out the sensor cable resistances.

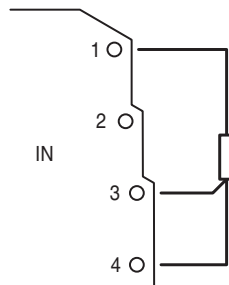

Figure 7 3-wire connection