



Chipsmall Limited consists of a professional team with an average of over 10 year of expertise in the distribution of electronic components. Based in Hongkong, we have already established firm and mutual-benefit business relationships with customers from,Europe,America and south Asia,supplying obsolete and hard-to-find components to meet their specific needs.

With the principle of “Quality Parts,Customers Priority,Honest Operation,and Considerate Service”,our business mainly focus on the distribution of electronic components. Line cards we deal with include Microchip,ALPS,ROHM,Xilinx,Pulse,ON,Everlight and Freescale. Main products comprise IC,Modules,Potentiometer,IC Socket,Relay,Connector.Our parts cover such applications as commercial,industrial, and automotives areas.

We are looking forward to setting up business relationship with you and hope to provide you with the best service and solution. Let us make a better world for our industry!



Contact us

Tel: +86-755-8981 8866 Fax: +86-755-8427 6832

Email & Skype: info@chipsmall.com Web: www.chipsmall.com

Address: A1208, Overseas Decoration Building, #122 Zhenhua RD., Futian, Shenzhen, China



Temperature measuring transducer - MINI MCR-SL-PT100-UI-200-NC - 2864370

Please be informed that the data shown in this PDF Document is generated from our Online Catalog. Please find the complete data in the user's documentation. Our General Terms of Use for Downloads are valid (<http://phoenixcontact.com/download>)



MCR temperature transducer, configurable, for Pt 100 temperature sensors, with screw-connection, not configured

Why buy this product

- ✓ Power supply possible via the foot element (TBUS)
- ✓ Optimized temperature measuring range of -50°C to +200°C for increased accuracy
- ✓ For 2, 3 or 4-wire Pt 100 sensors according to IEC 60751
- ✓ Error indication via diagnostic LED and analog signal
- ✓ Pt 100 signals to create standard signals
- ✓ 3-way isolation
- ✓ Highly-compact temperature transducer for electrical isolation, conversion, amplification, and filtering of
- ✓ Input and output signals can be configured via DIP switches



Key Commercial Data

Packing unit	1 STK
GTIN	 4 046356 046480
GTIN	4046356046480

Technical data

Note

Utilization restriction	EMC: class A product, see manufacturer's declaration in the download area
-------------------------	---

Dimensions

Width	6.2 mm
Height	93.1 mm
Depth	102.5 mm

Temperature measuring transducer - MINI MCR-SL-PT100-UI-200-NC - 2864370

Technical data

Ambient conditions

Ambient temperature (operation)	-20 °C ... 65 °C
Ambient temperature (storage/transport)	-40 °C ... 85 °C

Input data

Sensor types (RTD) that can be used	Pt 100 (IEC 60751/EN 60751)
Sensor input current	1 mA (constant)
Temperature measuring range	-50 °C ... 200 °C
Connection technology	2, 3, 4-wire

Output data

Number of outputs	1
Configurable/programmable	Yes
Voltage output signal	0 V ... 10 V
	10 V ... 0 V
	0 V ... 5 V
	1 V ... 5 V
Current output signal	0 mA ... 20 mA
	4 mA ... 20 mA
	20 mA ... 0 mA
	20 mA ... 4 mA
Max. output voltage	approx. 12.5 V
Max. output current	23 mA
Short-circuit current	approx. 10 mA
Load/output load voltage output	> 10 kΩ
Load/output load current output	< 500 Ω (at 20 mA)
Ripple	< 20 mV _{PP} (at 500 Ω)
	< 20 mV _{PP} (at 10 kΩ)

Power supply

Nominal supply voltage	24 V DC
Supply voltage range	19.2 V DC ... 30 V DC (The DIN rail bus connector (ME 6,2 TBUS-2 1,5/5-ST-3,81 GN, Order No. 2869728) can be used to bridge the supply voltage. It can be snapped onto a 35 mm DIN rail according to EN 60715))
Max. current consumption	< 21 mA (at 24 V DC)
Power consumption	< 500 mW

Connection data

Connection method	Screw connection
Conductor cross section solid min.	0.2 mm ²
Conductor cross section solid max.	2.5 mm ²
Conductor cross section AWG min.	26

Temperature measuring transducer - MINI MCR-SL-PT100-UI-200-NC - 2864370

Technical data

Connection data

Conductor cross section AWG max.	12
Conductor cross section flexible min.	0.2 mm ²
Conductor cross section flexible max.	2.5 mm ²
Stripping length	12 mm
Screw thread	M3

General

Transmission error in the set measuring range	((50 K / Δ Temp)+ 0.05)%
Transmission error in the full measuring range	≤ 0,25 %
Maximum temperature coefficient	< 0.02 %/K
Protective circuit	Transient protection
Electrical isolation	Basic insulation according to EN 61010
Overvoltage category	II
Degree of pollution	2
Rated insulation voltage	50 V AC/DC
Test voltage, input/output/supply	1.5 kV (50 Hz, 1 min.)
Electromagnetic compatibility	Conformance with EMC directive
Noise emission	EN 61000-6-4
Noise immunity	EN 61000-6-2 When being exposed to interference, there may be minimal deviations.
Color	green
Housing material	PBT
Mounting position	any
Conformance	CE-compliant
ATEX	# II 3 G Ex nA IIC T4 Gc X
UL, USA/Canada	UL 508 Recognized
	Class I, Div. 2, Groups A, B, C, D T5
GL	GL EMC 2 D
Fire protection for rail vehicles (DIN EN 45545-2) R22	HL 1 - HL 2
Fire protection for rail vehicles (DIN EN 45545-2) R23	HL 1 - HL 2
Fire protection for rail vehicles (DIN EN 45545-2) R24	HL 1 - HL 2

EMC data

Designation	Electromagnetic RF field
Standards/regulations	EN 61000-4-3
Typical deviation from the measuring range final value	10 %
Designation	Fast transients (burst)
Standards/regulations	EN 61000-4-4
Typical deviation from the measuring range final value	10 %
Designation	Conducted interferences
Standards/regulations	EN 61000-4-6

Temperature measuring transducer - MINI MCR-SL-PT100-UI-200-NC - 2864370

Technical data

EMC data

Typical deviation from the measuring range final value	10 %
--	------

Standards and Regulations

Electromagnetic compatibility	Conformance with EMC directive
Noise emission	EN 61000-6-4
Connection in acc. with standard	CUL
Standards/regulations	EN 61000-4-2
Designation	Electromagnetic RF field
Standards/regulations	EN 61000-4-3
	EN 61000-4-4
	EN 61000-4-5
Designation	Conducted interferences
Standards/regulations	EN 61000-4-6
Electrical isolation	Basic insulation according to EN 61010
Conformance	CE-compliant
ATEX	# II 3 G Ex nA IIC T4 Gc X
UL, USA/Canada	UL 508 Recognized
	Class I, Div. 2, Groups A, B, C, D T5
GL	GL EMC 2 D
Fire protection for rail vehicles (DIN EN 45545-2) R22	HL 1 - HL 2 HL 1 - HL 2 HL 1 - HL 2
Fire protection for rail vehicles (DIN EN 45545-2) R23	HL 1 - HL 2 HL 1 - HL 2 HL 1 - HL 2
Fire protection for rail vehicles (DIN EN 45545-2) R24	HL 1 - HL 2 HL 1 - HL 2 HL 1 - HL 2
Fire protection for rail vehicles (DIN EN 45545-2) R26	HL 1 - HL 2 HL 1 - HL 2 HL 1 - HL 2

Environmental Product Compliance

China RoHS	Environmentally Friendly Use Period = 50
	For details about hazardous substances go to tab "Downloads", Category "Manufacturer's declaration"

Drawings

Temperature measuring transducer - MINI MCR-SL-PT100-UI-200-NC - 2864370

Block diagram

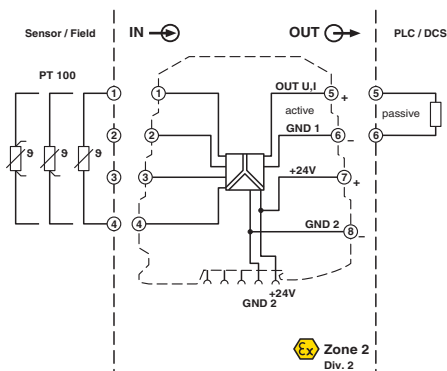

Dimensional drawing

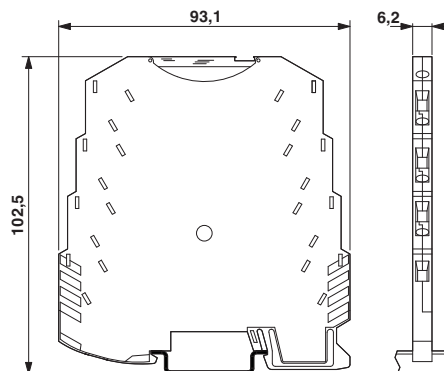

Approvals

Approvals

Approvals

UL Recognized / cUL Recognized / GL / cULus Recognized

Ex Approvals

UL Listed / cUL Listed / EAC Ex / ATEX / cULus Listed

Approval details

UL Recognized		http://database.ul.com/cgi-bin/XYV/template/LISEXT/1FRAME/index.htm	FILE E 238705
cUL Recognized		http://database.ul.com/cgi-bin/XYV/template/LISEXT/1FRAME/index.htm	FILE E 238705
GL		http://exchange.dnv.com/tari/	24917-05 HH
cULus Recognized		http://database.ul.com/cgi-bin/XYV/template/LISEXT/1FRAME/index.htm	

Phoenix Contact 2018 © - all rights reserved
<http://www.phoenixcontact.com>

PHOENIX CONTACT GmbH & Co. KG
Flachmarktstr. 8
32825 Blomberg
Germany
Tel. +49 5235 300
Fax +49 5235 3 41200
<http://www.phoenixcontact.com>