



Chipsmall Limited consists of a professional team with an average of over 10 year of expertise in the distribution of electronic components. Based in Hongkong, we have already established firm and mutual-benefit business relationships with customers from,Europe,America and south Asia,supplying obsolete and hard-to-find components to meet their specific needs.

With the principle of “Quality Parts,Customers Priority,Honest Operation,and Considerate Service”,our business mainly focus on the distribution of electronic components. Line cards we deal with include Microchip,ALPS,ROHM,Xilinx,Pulse,ON,Everlight and Freescale. Main products comprise IC,Modules,Potentiometer,IC Socket,Relay,Connector.Our parts cover such applications as commercial,industrial, and automotives areas.

We are looking forward to setting up business relationship with you and hope to provide you with the best service and solution. Let us make a better world for our industry!



## Contact us

Tel: +86-755-8981 8866 Fax: +86-755-8427 6832

Email & Skype: info@chipsmall.com Web: www.chipsmall.com

Address: A1208, Overseas Decoration Building, #122 Zhenhua RD., Futian, Shenzhen, China



# MACX MCR-PTB(-SP)



## Power and error message module

### INTERFACE

Data sheet  
103618\_en\_00

© PHOENIX CONTACT - 10/2008

## 1 Description

The power module MACX MCR-PTB(-SP) enables the supply voltage on the foot elements (DIN rail connectors) to be provided on either a redundant or a non-redundant basis.

The module MACX MCR-PTB(-SP) has integrated error evaluation. An auxiliary supply failure or fuse error is registered to a relay contact and displayed via a flashing LED.

With MACX MCR-EX-SL-(2)NAM... devices connected via DIN rail connectors, a collection line fault is signaled.

The devices can be installed in zone 2 with the "n" (EN 60079-15) protection type.

### 1.1 Properties

- Power and error message module
- Supply of 24 V DC supply voltage on the DIN rail connector
- Redundant or non-redundant supply, decoupling via diodes
- Protected against polarity reversal
- Supply current up to 3.75 A
- Relay output for error message
- Replaceable fuse
- Installation in Zone 2 permissible
- With screw (MACX MCR-PTB) or spring-cage connection (MACX MCR-PTB-SP)



#### **WARNING: Explosion hazard**

**The device is an associated item of electrical equipment for intrinsically safe circuits. It is designed for use in zone 2, if specific conditions are observed.**

When installing and operating the device, the applicable safety directives (including national safety directives), accident prevention regulations, as well as general technical regulations, must be observed.



#### **WARNING: Explosion hazard**

**Be sure to observe the safety regulations and installation notes on page 4.**



Make sure you always use the latest documentation.  
It can be downloaded at [www.download.phoenixcontact.com](http://www.download.phoenixcontact.com).  
A conversion table is available on the Internet at  
[www.download.phoenixcontact.com/general/7000\\_en\\_00.pdf](http://www.download.phoenixcontact.com/general/7000_en_00.pdf).



This data sheet is valid for all products listed on the following page:

## Table of contents

1	Description.....	1
2	Ordering data.....	2
3	Technical data .....	2
4	Safety regulations and installation notes.....	4
5	Installation .....	5

## 2 Ordering data

### Power and error message module

Description	Type	Order No.	Pcs./Pkt.
Power and error message module, including the relevant DIN rail connector ME 17.5 TBUS 1.5/5-ST-3.81 GN with screw connection	MACX MCR-PTB	2865625	1
Power and error message module, including the relevant DIN rail connector ME 17.5 TBUS 1.5/5-ST-3.81 GN with spring-cage connection	MACX MCR-PTB-SP	2924184	1

## 3 Technical data

### Input

Input signal	19.2 V DC ... 30 V DC
Redundant supply	Decoupling via diodes
Protection against polarity reversal and surge protection	Yes

### Output

Maximum output current	$I_{OUT} = 3.75 \text{ A}$
Output voltage for $I_{OUT}$	$U_{IN} - 0.8 \text{ V}$

### Switching output

Contact type	1 x PDT
Contact material	Au
Maximum switching voltage	50 V AC (2 A)

### General data

Current consumption	3.75 A
Ambient temperature	
Operation	-20°C ... +60°C
Storage/transport	-40°C ... +80°C
Permissible humidity (operation)	10% ... 95% (no condensation)
Fuse	Replaceable, 5 A (slow-blow 250 V AC)
Status indicator	2 LEDs green (supply voltage PWR 1 and PWR 2) LED red (error)
Housing material	Polyamide
Color	Green
Degree of protection	IP20
Width x length x height	17.5 mm x 114.5 mm x 104 mm (with connection terminal block)
Inflammability class according to UL 94	V0
Design	Terminal block housing for mounting on DIN rails

**Conformance**

EMC directive 2004/108/EC	EN 61000-6-2, EN 61000-6-4, EN 61326-1
Ex directive (ATEX)	EN 60079-0, EN 60079-11, EN 60079-15

**Certificates**

ATEX	Ⓔ II 3 G Ex nAC II T4 X
IECEX	Ex nAC IIC T4 X IECEx IBE 08.0004X
UL USA/Canada	UL applied for

**Connection data MACX MCR-PTB**

Conductor cross-section	
Solid (minimum/maximum)	0.75 mm <sup>2</sup> /2.5 mm <sup>2</sup>
Stranded (minimum/maximum)	0.75 mm <sup>2</sup> /2.5 mm <sup>2</sup>
AWG/kcmil (minimum/maximum)	18/14
Stripping length	7 mm
Connection method	Pluggable screw connection
Tightening torque	0.5 Nm, minimum/0.6 Nm, maximum

**Connection data MACX MCR-PTB-SP**

Conductor cross-section	
Solid (minimum/maximum)	0.75 mm <sup>2</sup> /1.5 mm <sup>2</sup>
Stranded (minimum/maximum)	0.75 mm <sup>2</sup> /1.5 mm <sup>2</sup>
AWG/kcmil (minimum/maximum)	18/16
Stripping length	8 mm
Connection method	Spring-cage connection

## 4 Safety regulations and installation notes

### 4.1 Installation and operation

Follow the installation instructions.



**NOTE:** Installation, operation, and maintenance may only be carried out by qualified specialist personnel.

When installing and operating the device, the applicable safety directives (including national safety directives), accident prevention regulations, as well as general technical regulations must be observed.



**NOTE:** The circuits inside the device must not be accessed.

Do not repair the device yourself, but replace it with an equivalent device. Repairs may only be carried out by the manufacturer.



**NOTE:** The device is designed to meet IP20 protection when:

- It is installed outside potentially explosive areas.
- The environment is clean and dry.

Install the device in a suitable housing with a suitable degree of protection in accordance with IEC 60529 in order to protect it from mechanical and electrical damage.

For the safety data, please refer to the operating instructions and certificates and other approvals, if necessary.

### 4.2 Safety regulations for installation in the potentially explosive area

#### Installation in zone 2



**WARNING: Explosion hazard**

The device is classed as category 3 electrical equipment and is suitable for installation in zone 2.

Observe the specified conditions for use in potentially explosive areas.



**WARNING: Explosion hazard**

Install the device in suitable **housing with a minimum of IP54 degree of protection**. Observe the requirements of IEC 60079-14/ EN 60079-14, e.g., steel housing with a wall thickness of 3 mm.



**WARNING: Explosion hazard**

Disconnect the block **power supply before:**

- Snapping it on or disconnecting it
- Connecting or disconnecting cables
- Changing the fuse



**WARNING: Explosion hazard**

Use the specified fuse type only (see page 2).



**WARNING: Explosion hazard**

Only use category 3G modules (ATEX 94/9/EC).

## 5 Installation



**NOTE: Electrostatic discharge**

The device contains components that can be damaged or destroyed by electrostatic discharge. When handling the device, observe the necessary safety precautions against electrostatic discharge (ESD) according to EN 61340-5-1 and EN 61340-5-2.



**NOTE: Electrostatic discharge**

Take protective measures against electrostatic discharge before opening the front cover.

### 5.1 Basic circuit diagram

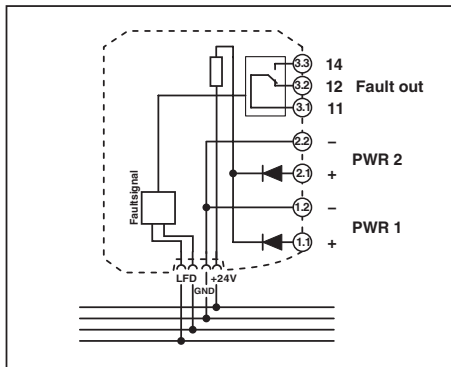

Figure 1 Basic circuit diagram with connection terminal blocks

### 5.2 Design

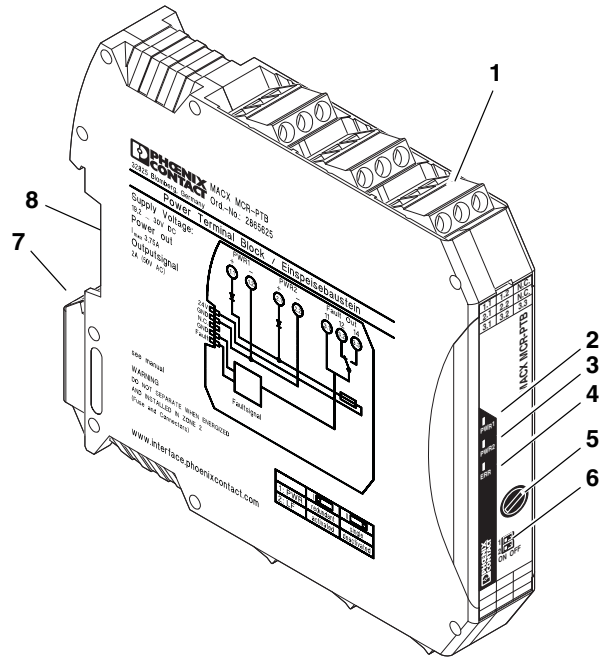

Figure 2 Design

- 1 Pluggable COMBICON connection terminal blocks
- 2 LED PWR 1, supply voltage 1
- 3 LED PWR 2, supply voltage 2
- 4 LED ERR, error
- 5 Fuse
- 6 DIP switches
- 7 Metal lock for fixing on the DIN rail
- 8 Connection option for DIN rail connector

### 5.3 Dimensions

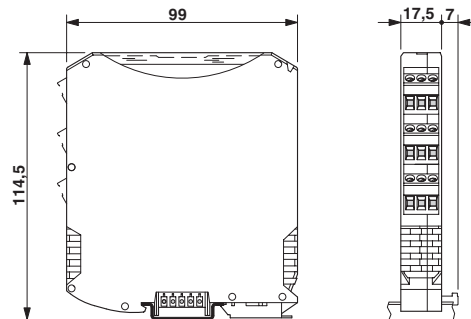

Figure 3 Dimensions (in mm)

### 5.4 Mounting

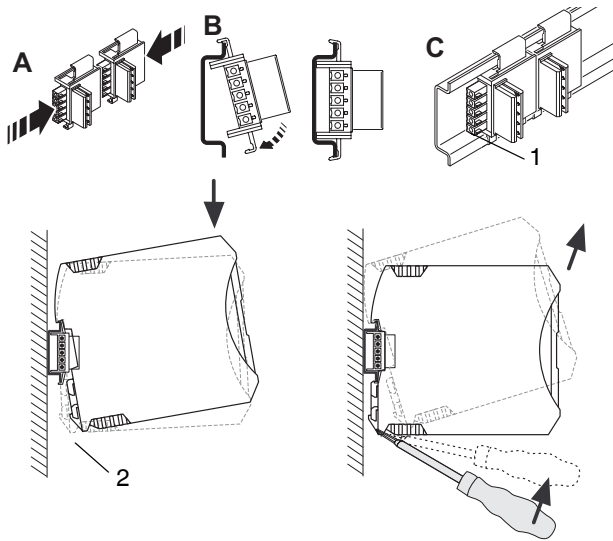

Figure 4 Assembly and removal

- Mount the module on a 35 mm DIN rail according to EN 60715.
- First insert the ME 17.5 TBUS DIN rail connector (included in the scope of supply) into the DIN rail (see A – C, Figure 4).
- Please also ensure you observe the direction of the module and DIN rail connector when snapping into position:  
Snap-on foot below (2) and connector left (1).
- Install the module in suitable housing to meet the requirements for the protection class.
- Before startup, check that the repeater power supply is operating and wired correctly, especially with regard to the wiring and labeling of the intrinsically safe circuits.

### 5.5 Connecting the cables

- Pluggable screw terminal blocks (on MACX MCR-PTB); litz wires provided with ferrules. Permissible cable cross-section: 0.75 mm<sup>2</sup> to 2.5 mm<sup>2</sup>.
- Pluggable spring-cage terminal blocks (on MACX MCR-PTB-SP); litz wires provided with ferrules. Permissible cable cross-section: 0.75 mm<sup>2</sup> to 1.5 mm<sup>2</sup>.
- **Screw connection:**
  - Insert the wire into the corresponding connection terminal block.
  - Use a screwdriver to tighten the screw in the opening above the connection terminal block.
- **Spring-cage connection:**
  - Insert a screwdriver in the opening above the connection terminal block.
  - Insert the wire into the corresponding connection terminal block.

### 5.6 Voltage supply



**NOTE:** It is not permitted to draw power from the DIN rail connector or from individual modules.

### 5.7 Configuration

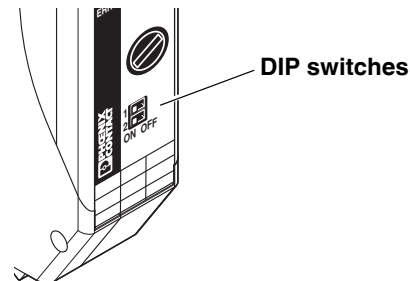

Figure 5 DIP switches

If the supply for the MACX MCR-PTB(-SP) is non-redundant (as opposed to redundant), the relevant error message can be disabled via the DIP switch (switch 1= II).

Similarly, the group error message for the connected devices can also be enabled or disabled (switch 2).

	I	II
1	Redundancy operation	Single power
2	Error message on	Error message off