



Chipsmall Limited consists of a professional team with an average of over 10 year of expertise in the distribution of electronic components. Based in Hongkong, we have already established firm and mutual-benefit business relationships with customers from,Europe,America and south Asia,supplying obsolete and hard-to-find components to meet their specific needs.

With the principle of “Quality Parts,Customers Priority,Honest Operation,and Considerate Service”,our business mainly focus on the distribution of electronic components. Line cards we deal with include Microchip,ALPS,ROHM,Xilinx,Pulse,ON,Everlight and Freescale. Main products comprise IC,Modules,Potentiometer,IC Socket,Relay,Connector.Our parts cover such applications as commercial,industrial, and automotives areas.

We are looking forward to setting up business relationship with you and hope to provide you with the best service and solution. Let us make a better world for our industry!



Contact us

Tel: +86-755-8981 8866 Fax: +86-755-8427 6832

Email & Skype: info@chipsmall.com Web: www.chipsmall.com

Address: A1208, Overseas Decoration Building, #122 Zhenhua RD., Futian, Shenzhen, China



Uninterruptible Power Supply Unit for Universal Use QUINT-DC-UPS/24DC/40

1. Short Description

Uninterruptible Power Supply Units for Buffering Long-Term Power Interruptions

- Saves space thanks to the compact, uniform design
- Integrated diode saves money through isolation of loads
- Maximum system availability through optimum battery management and reliable signaling
- Minimum installation time due to ready-to-use plug-in bridges and integrated timeout

QUINT-DC-UPS uninterruptible power supply units with long-life lead-acid batteries provide long buffer times at high currents. Even in the event of a longer supply voltage failure, the units ensure that all connected devices continue to operate without interruption.

The devices have a narrow and uniform design, which makes them ideal for use on the DIN rail where space is limited. In addition, short wiring paths ensure order and clarity in the control cabinet.

The high level of availability and the particularly long service life of the battery modules are achieved through professional battery management. An automatic presence check (every minute), automatic quality test (once a week), temperature-determined charging, and electronic overcurrent protection ensure the battery modules are ready to operate at all times. Power is therefore available in the event of an error and the service life of the battery module is maximized.

The actual state must be determined quickly so that the right decision can be made in an emergency. Optimum signaling is thus required for maximum system availability. Three floating PDT contacts and three LEDs are provided for function monitoring, which indicate all the operating states clearly.

So that relay signaling is more reliable and more durable than before, an additional positive supply output has been provided. The contact, which is current-limited and resistant to continued short circuits, is located next to the relay connections and enables easy bridging. In the event of wiring errors, the short-circuit protection prevents any welding of the relay contacts. This ensures that the user can rely on an OK signal. Even in the event of connection errors, currents remain below 100 mA, which prevents damage to the relay contacts.



A system is switched off after a specific time that can be set on the device or by an external signal. No additional installation is required for shutdown. In addition, ready-to-use plug-in bridges minimize the installation time.

The connected devices can be divided into buffered and unbuffered loads using the isolated input. This extends the buffer time, which depends on the output current. If only critical devices are protected using fuses, smaller battery modules can be used that save money and space in the control cabinet. In addition, the isolated input protects the connected devices against errors in the internal network.

2. Technical Data

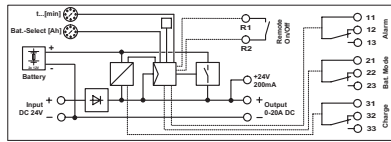

QUINT-DC-UPS/24DC/40

	Solid	Stranded	AWG	Torque	
	[mm ²]	[mm ²]		[Nm]	[lb in]
Input	0.5 - 16	0.5 - 10	20 - 6	1.2 - 1.5	10.6 - 13.3
Output	0.5 - 16	0.5 - 10	20 - 6	1.2 - 1.5	10.6 - 13.3
Signal	0.2 - 2.5	0.2 - 2.5	25 - 14	0.5 - 0.6	4.5 - 5.3

Description

Uninterruptible power supply unit
 3.4 Ah battery module
 7.2 Ah battery module
 12 Ah battery module

Technical Data

Input Data

Nominal input voltage
 Input voltage range
 Current consumption (No load/charging/maximum)
 Switching threshold
 Buffer time Can be configured
 Input fuse
 Maximum power dissipation (Ready/buffer mode)

Output Data

Can be connected in parallel (battery module)

Output Data in Normal Operation

Nominal output voltage
 Output voltage
 Output current
 Current limit
 Overload fuse

Output Data in Buffer Mode

Nominal output voltage
 Output voltage Maximum
 Output current
 Current limit
 Overload fuse
 Level of efficiency Typical
 Remote shutdown

Charging

Charge characteristic curve
 End-of-charge voltage
 Charge current
 Battery/presence check/time interval
 Battery/quality test/time interval

Memory Medium

Nominal voltage
 Nominal capacity
 Charge current

DC UPS Module



10 mm (0.39 in.)



7 mm (0.28 in.)



Type

QUINT-DC-UPS/24DC/40
 QUINT-BAT/24DC/3,4Ah
 QUINT-BAT/24DC/7,2Ah
 QUINT-BAT/24DC/12Ah

Order No.

28 66 24 2
 28 66 34 9
 28 66 35 2
 28 66 36 5

Pcs. Pkt.

1

24 V DC
 22.5 - 30 V DC
 0.1 A/2.5 A/42.5 A
 $U_a < 22 V$; dynamic $U_{in} - 1 V/0.1 s$
 0.5; 1; 2; 3; 10; 15; 20; 30; continuous
 Internal, 50 A
 20 W/30 W

Yes, to increase the buffer time

24 V DC
 U_{in}
 40 A
 None
 Internal, 50 A

24 V DC
 27.9 V DC
 40 A (25 A for 3.4 Ah battery module)
 45 A
 Electronic
 98%
 Yes

I/U characteristic curve
 Temperature compensated
 $< 2.5 A$
 60 seconds
 180 hours

External
 24 V DC
 3.4 Ah, 7.2 Ah, 12 Ah
 $< 2.5 A$

Uninterruptible Power Supply Unit for Universal Use – QUINT-DC-UPS/24DC/40

Signaling		
Power In OK		Green LED
Alarm		Red LED, floating PDT, 30 V AC/DC, maximum; 1 A, maximum
Battery Mode		Yellow LED, floating PDT, 30 V AC/DC, maximum; 1 A, maximum
Battery Charge		Yellow LED, flashing, floating PDT, 30 V AC/DC, maximum; 1 A, maximum
Approvals/Standards		
Electrical equipment of machines		EN 60 204 (Surge Voltage Category III)
Electrical safety (of IT equipment)		EN 60950/VDE 0805, UL/C-UL Recognized UL 60 950
Industrial control equipment		UL/C-UL Listed UL 508
Shipbuilding		Germanischer Lloyd
Electronic equipment for use in electrical power installations		EN 50 178/VDE 0160
General Data		
Insulation voltage	Input/output to housing:	1 kV AC type test 1 kV AC routine test
Mounting position		On a horizontal 35 mm (1.378 in.) DIN rail EN 60 715 1 kV/1 kV
Degree of protection		IP20
Class of protection		II
MTBF	According to IEC 1709 (SN 29 500)	> 500,000 h
Housing version		AluNox (AlMg1), closed
Dimensions (W x H x D) default upon delivery		(66 x 130 x 125 mm [2.598 x 5.118 x 4.921 in.])
Dimensions (W x H x D) rotated 90°		(122 x 130 x 69 mm [4.803 x 5.118 x 2.717 in.])
Weight	Approximately	0.9 kg
Climatic Data		
Ambient temperature	Operation/storage	-25°C to +70°C (-13°F to +158°F)/-40°C to +85°C (-40°F to +185°F)
Humidity	At +25°C (+77°F)	95%, no condensation
Vibration	According to IEC 68-2-6	15 - 150 Hz, 2.3g, 90 minutes
Shock (in all space directions)	According to IEC 68-2-6	30g
Pollution degree	According to EN 50 178	2
Climatic category	According to EN 60 721	3K3



Conformance With EMC Directive 89/336/EEC and Low Voltage Directive 73/23/EEC

EMC (Electromagnetic Compatibility)	Requirements	QUINT-DC-UPS/24DC/40
Noise Immunity According to EN 61000-6-2:	EN 61 000-6-2	
Noise Immunity According to EN 61000-6-2		
• EN 61000-4-2 ³⁾ Electrostatic discharge (ESD)	Housing Contact discharge: Air discharge:	Level 4 8 kV 15 kV
• EN 61000-4-3 ²⁾ Electromagnetic HF field	Housing Frequency: Field strength:	Level 3 80 - 1000 MHz/1.4 - 2.0 GHz 10 V/m
• EN 61000-4-4 ³⁾ Fast transients (burst):	Input: Output: Signal:	2 kV 2 kV 1 kV asymmetrical ⁵⁾ asymmetrical ⁵⁾ asymmetrical ⁵⁾
• EN 61000-4-5 ³⁾ Surge current loads (surge):	Input: Output: Signal:	2 kV 2 kV 0.5 kV 0.5 kV 1 kV asymmetrical ⁵⁾ symmetrical ⁴⁾ asymmetrical ⁵⁾ symmetrical ⁴⁾ asymmetrical ⁵⁾
• EN 61000-4-6 ²⁾ Conducted interference	I/O/S: Frequency: U ₀ :	asymmetrical ⁵⁾ Level 3 0.15 - 80 MHz 10 V
• EN 61000-4-11 ³⁾ Voltage dips	Input:	30% reduction of the input voltage for 0.5 periods See Input Data: Mains buffering > 20 ms
Noise Emission According to EN 50081-2		
• Radio interference emission	EN 55011	EN 55011 (EN 55022) Class B ⁷⁾
• Radio interference voltage	EN 55011	EN 55011 (EN 55022) Class B ⁷⁾

EN 55011 corresponds to CISPR11/EN 55022 corresponds to CISPR22/EN 61000 corresponds to IEC 1000

²⁾ Criterion A: Normal operating characteristics within the specified limits.

³⁾ Criterion B: Temporary adverse effects on the operating characteristics that the device corrects automatically.

⁴⁾ Symmetrical: Cable to cable.
⁵⁾ Asymmetrical: Cable to ground.
⁶⁾ Class A: Industrial applications
⁷⁾ Class B: Industrial and domestic applications

3. Device View, Connections, and Control Elements

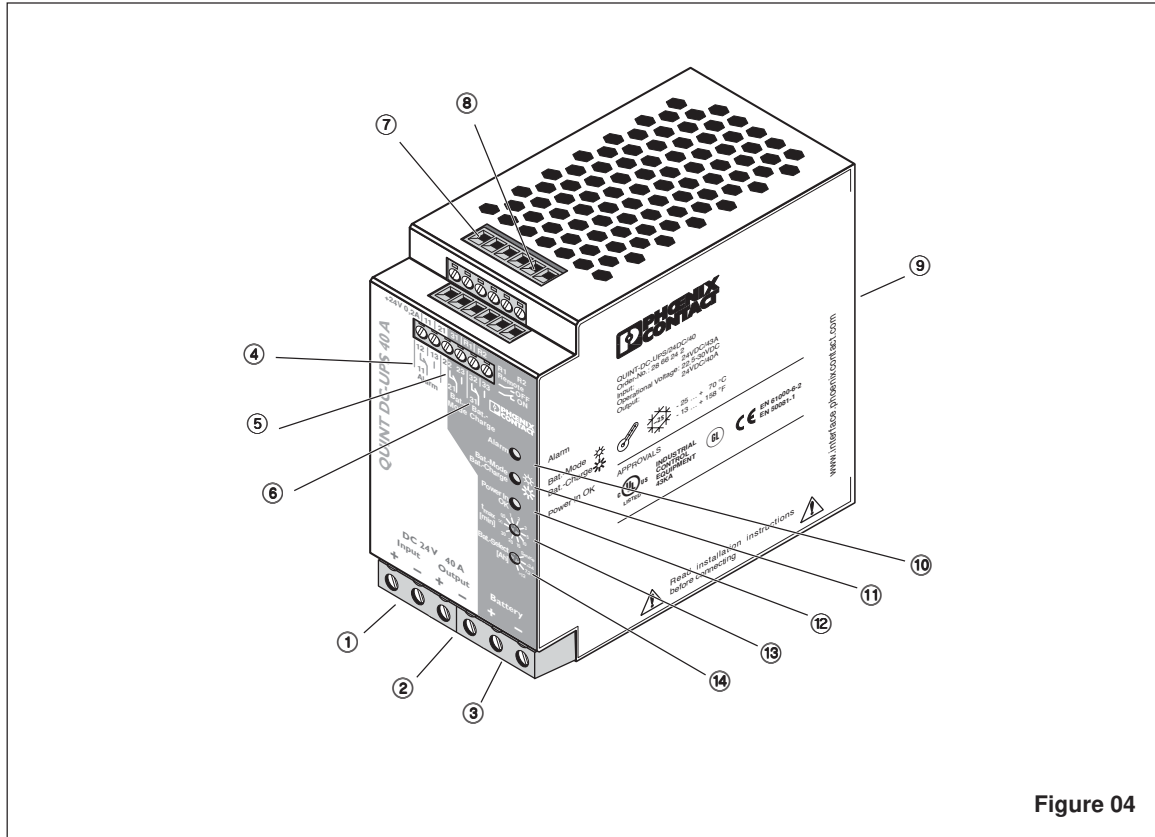

Figure 04

- ① **DC input, unbuffered**
24 V DC input voltage
(0.5 mm² to 16 mm² solid)
(0.5 mm² to 10 mm² stranded)
(20 - 6 AWG)
Internal fuse 50 AT
- ② **DC output, buffered**
24 V DC output voltage
(0.5 mm² to 16 mm² solid)
(0.5 mm² to 10 mm² stranded) (20 - 6 AWG)
The device is idling-proof and short-circuit-proof.
- ③ 24 V battery module connection
- ④ Floating PDT (11,12,13): Alarm
- ⑤ Floating PDT (21,22,23): Battery Mode
- ⑥ Floating PDT (31,32,33): Battery Charge
- ⑦ 24 V supply voltage, maximum current limit 0.2 A for grouped contacts 11, 21, 31
- ⑧ Remote shutdown (R1, R2)
- ⑨ Universal DIN rail adapter UTA 107
- ⑩ Red LED: Alarm
- ⑪ Yellow LED: Battery Mode/Battery Charge
- ⑫ Green LED: Power In OK
- ⑬ Buffer time setting 0.5 - 30 minutes
- ⑭ Battery module/Service setting selection

4. Safety Notes and Warning Instructions

To ensure that the device can be operated safely and all functions can be used, please read these instructions carefully.

The QUINT-DC-UPS is a built-in device. **Installation and startup** must only be carried out by qualified personnel. The relevant country-specific regulations (e.g., VDE, DIN) must also be observed.

Before startup it is particularly important to ensure that:

- All supply lines have sufficient fuse protection and are the correct size.
- All output cables are the correct size for the maximum device output current or have separate fuse protection.
- Sufficient convection is ensured.
- The fuse on the battery module is always removed when carrying out any work.

5. Installation

5.1. Mounting

The uninterruptible power supply unit together with the battery module can be snapped onto all DIN rails according to EN 60715 and should be mounted horizontally (input terminal blocks facing downwards).

Installation Dimensions



No minimum spacing to other modules is required for proper operation of the device.

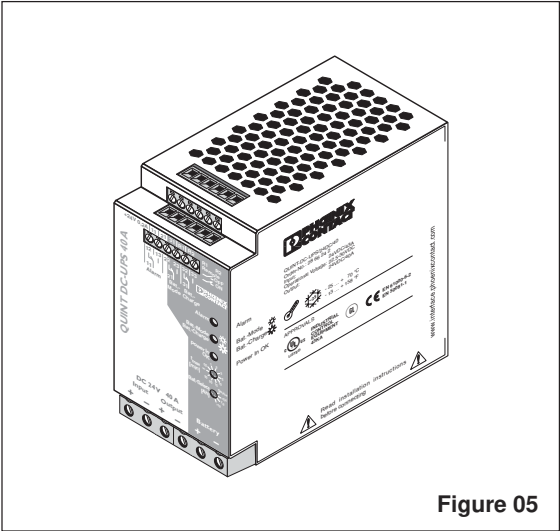

Figure 05

5.2. Narrow Mounting Position

The device is supplied ex works for a narrow mounting position.

Mounting:

Place the module with the DIN rail guideway on the **top edge** of the DIN rail and then snap it **downwards**.

Removal:

Release the snap-on catch using a screwdriver and then detach the module from the **bottom edge** of the DIN rail.

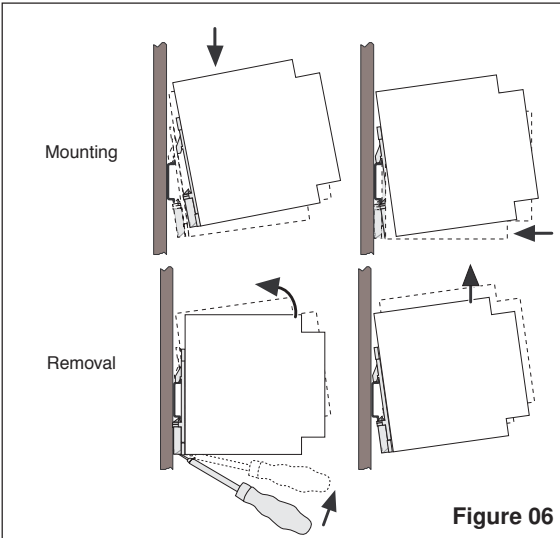

Figure 06

5.3. Flat Mounting Position

A flat mounting position can be achieved by mounting the module onto the DIN rail at a 90° angle. To do this, mount the DIN rail adapter (UTA 107) ⑦ as shown in Figure 07. No additional assembly material is required. Mounting screws: Torx T10 (torque 0.8 - 0.9 Nm).

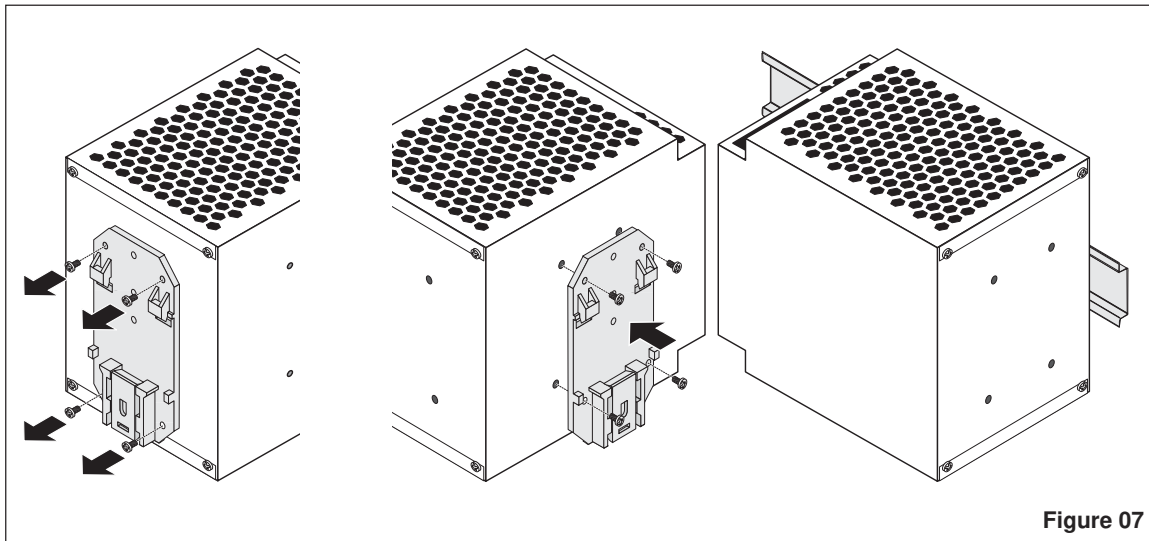

Figure 07

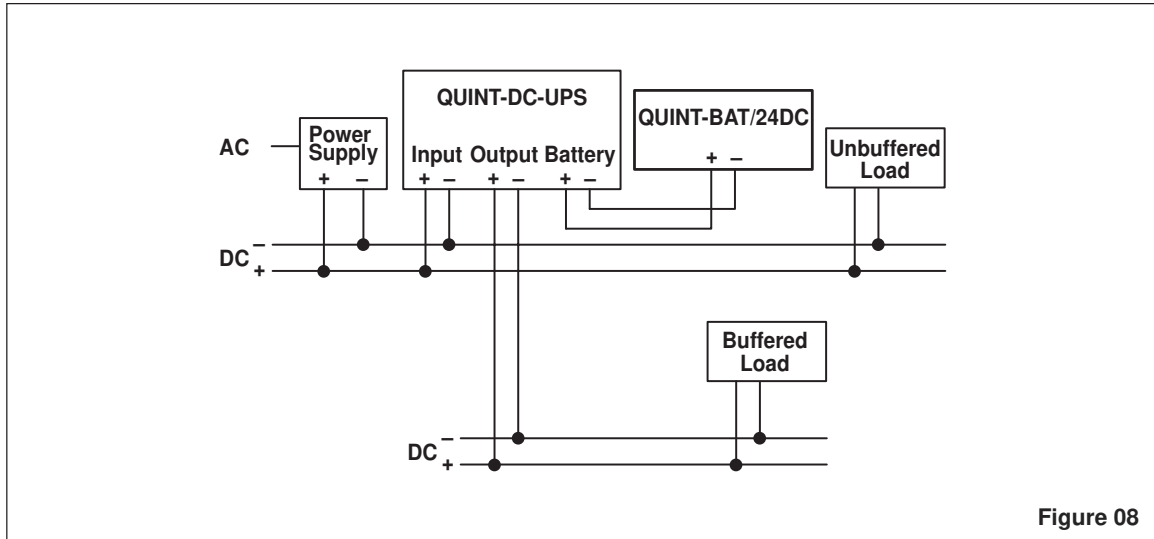

Figure 08

5.4. Connection

The following cable cross sections can be connected:

	Solid [mm ²]	Stranded [mm ²]	AWG	Torque [Nm]
① Input:	0.5 - 16	0.5 - 10	20 - 6	1.2 - 1.5
② Output:	0.5 - 16	0.5 - 10	20 - 6	1.2 - 1.5
③ Battery:	0.5 - 16	0.5 - 10	20 - 6	1.2 - 1.5
④-⑧ Signal:	0.2 - 4	0.2 - 2.5	25 - 14	0.5 - 0.6

For reliable and safe-to-touch connections: Strip 10 mm (0.39 in.) from the input and output side connector ends and 7 mm (0.28 in.) from the signal connector ends.

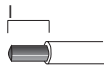

To maintain UL approvals, use copper cables, which are designed for operating temperatures > +75°C (+167°F). To meet GL requirements, unused terminal compartments should be closed.

5.5. Input (①, Figure 04, Figure 08)

The QUINT-DC-UPS is connected to the 24 V DC output of the power supply via the "Input +" and "Input -" terminal blocks. The output is isolated from the input by the internal diode. The stored power is only supplied to the output. The device is protected against overcurrent and short circuit by an internal input fuse.

Fuse

Further device protection is not required, as an internal fuse is present.



If the internal fuse is blown, this is most probably due to a device fault. In this case, the device should be checked in the factory.

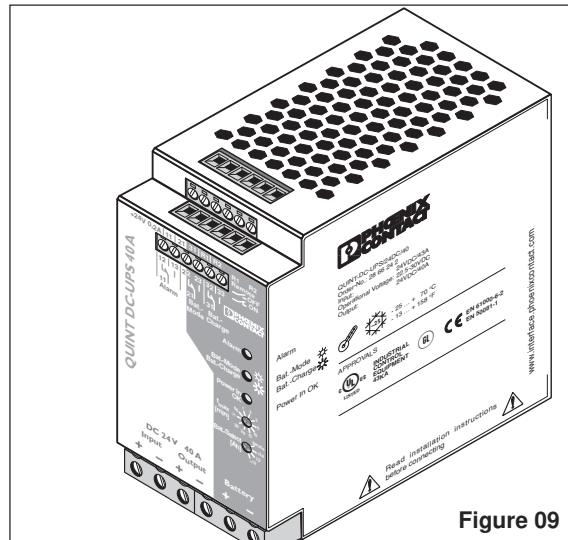

Figure 09

5.6. Output

All devices that must be supplied without interruption in the event of a supply voltage failure ("Buffered Load"), are connected to the "Output +" and "Output -" terminal blocks of the DC output (Fig. 08). It is recommended that all other loads, which do not require buffering ("Unbuffered Load"), are connected to the 24 V DC output of the power supply.

This increases the buffer time, as this time depends on the output current (see Fig. 10). The internal diode ensures that the buffered loads are isolated from the unbuffered loads.

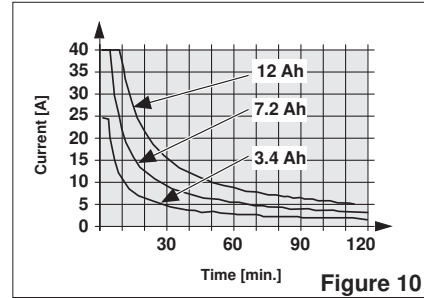

Figure 10

5.7. Battery Module

The battery module is connected to the QUINT-DC-UPS via the "Battery +" and "Battery -" terminal blocks. To interrupt the charge/discharge current of the battery module, the "Battery module selection" selector switch (14) must be set to "Service".



The fuse on the battery module must be removed when installing or replacing the battery module.

The QUINT-DC-UPS is optimized for use with QUINT-BAT/24DC type battery modules.

The following battery modules are recommended:

QUINT-BAT/24DC/3,4AH (Order No. 2866349)

QUINT-BAT/24DC/7,2AH (Order No. 2866352)

QUINT-BAT/24DC/12AH (Order No. 2866365)

When using QUINT-BAT/24DC/3,4AH, the maximum output current of 25 A must not be exceeded.

Following successful installation, the capacity of the connected battery module must be selected using the "Battery module selection" rotary switch (14).

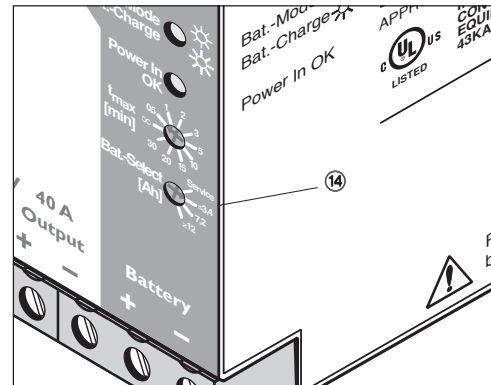

Figure 11

5.8. Signaling Outputs

The signal outputs are connected via terminal blocks 11/12/13 (4), 21/22/23 (5) or 31/32/33 (6). The contacts are floating contacts. The plug-in bridge provided can be used to supply +24 V to grouped contacts 11,21,31. This means that N/C contacts 12,22,32 and N/O contacts 13,23,33 can be evaluated as switching outputs with 0 V and +24 V voltage levels.

5.9. Remote Shutdown ("Remote", Fig. 12)

The device has a UPS remote shutdown function for specific shutdown.

Remote shutdown must be deactivated for the device to switch to buffer mode in the event of a supply voltage failure.

Remote Shutdown Off

- The "Remote shutdown R1" and "Remote shutdown R2" terminal points are short circuited (e.g., with a plug-in bridge) OR The "Remote shutdown R2" terminal point is supplied with a 24 V DC voltage
- The QUINT-DC-UPS switches to buffer mode in the event of a supply voltage failure

Remote Shutdown On

- The "Remote shutdown R1" and "Remote shutdown R2" terminal points are not connected
- All LEDs are off
- The QUINT-DC-UPS does not switch to buffer mode in the event of a supply voltage failure, instead the device is shut down. When the supply voltage is reapplied, the battery module is charged and the device remains off until remote shutdown is deactivated.
- Connected loads are supplied as long as the supply voltage is present

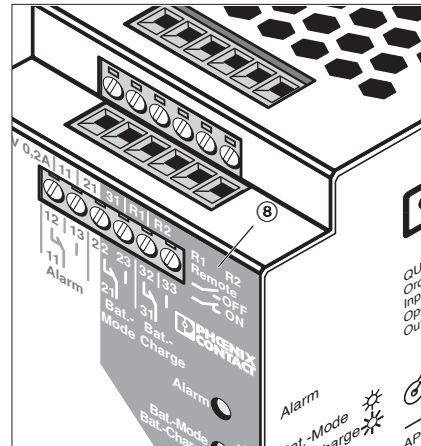

Figure 12

6. Setting Options on the Device

(Fig. 13)

6.1. Buffer Time Setting

Buffer mode can be exited after a predefined time has elapsed or by external shutdown (see 6.9).

If the device is to be shut down after a specific time has elapsed, the time can be set via the selector switch ⑬ on the front of the device. When the supply voltage is reapplied, the device can switch to buffer mode again.

6.2. Battery Module Setting

Before startup, the capacity of the battery module used must be set on the device via the selector switch ⑭. When replacing the battery, the selector switch must be set to "Service" (see also 6.7).

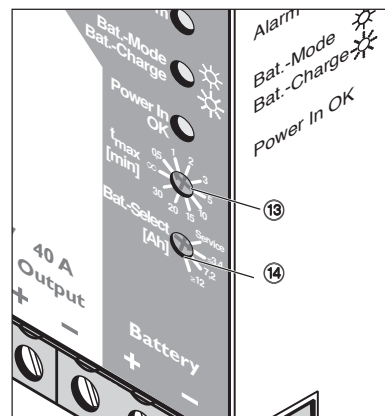

Figure 13

7. Method of Operation

In the event of a power failure at the output, the QUINT-DC-UPS supplies all connected devices with a 24 V DC voltage without interruption at a load current up to 40 A. When the 24 V supply voltage is applied, the connected battery module is charged. In the event of a supply voltage failure, the battery module is connected to the output, and the stored power ensures that all connected devices continue to operate without interruption. The professional signaling via function LEDs and floating PDT contacts enables reliable evaluation of all the main operating states.

7.1. Output Voltage

In normal operation, the QUINT-DC-UPS output voltage corresponds to the usual supply voltage. If the supply voltage drops more than 1 V in the space of 0.1 seconds or falls below the minimum threshold of 22 V, the device switches to buffer mode.

If the output voltage drops below 20.4 V in buffer mode, this is indicated by the Alarm indicator.

If the output voltage drops to 19.2 V because the battery module is flat, the device is shut down completely. When the supply voltage is reapplied, the device automatically switches on again. The device is electronically short-circuit-proof and idling-proof.

7.2. Signaling

Three floating PDT contacts and three indicators are provided for function monitoring.

Key/Indicators	Green ¹² Power IN OK	Yellow ¹¹ Bat. Mode/Charge	Red ¹⁰ Alarm
Supply voltage OK, battery module charging	ON	Flashing	OFF
Supply voltage OK, battery module charged (normal operation)	ON	OFF	OFF
Buffer mode	OFF	ON	OFF
Battery module flat	OFF	OFF	ON
- Battery module quality test negative - No battery module - Service	ON	OFF	ON
- Buffer time elapsed - Remote shutdown activated	OFF	OFF	OFF

xx - xx: Contact closed,
 1x Alarm, 2x Battery Mode, 3x Battery Charge
 x1 group contact, x2 N/C contact, x3 N/O contact

Key/Output	Bat. Charge ⁶	Bat. Mode ⁵	Alarm ⁴
Supply voltage OK, battery module charging	31 - 33	21 - 22	
Supply voltage OK, battery module charged (normal operation)	31 - 32	21 - 22	
Buffer mode	31 - 32	21 - 23	
Battery module flat	31 - 32	21 - 22	11 - 13
- Battery module quality test negative - No battery module - Service	31 - 32	21 - 22	11 - 13
- Buffer time elapsed - Remote shutdown activated		21 - 22	11 - 13

7.3. Temperature Response

The charging rate of the connected battery module depends on the temperature.

7.4. Testing the Battery Module

A quality test is carried out on the battery module once a week and its presence is verified every minute. A negative test result is indicated by the Alarm indicator.