



Chipsmall Limited consists of a professional team with an average of over 10 year of expertise in the distribution of electronic components. Based in Hongkong, we have already established firm and mutual-benefit business relationships with customers from,Europe,America and south Asia,supplying obsolete and hard-to-find components to meet their specific needs.

With the principle of “Quality Parts,Customers Priority,Honest Operation,and Considerate Service”,our business mainly focus on the distribution of electronic components. Line cards we deal with include Microchip,ALPS,ROHM,Xilinx,Pulse,ON,Everlight and Freescale. Main products comprise IC,Modules,Potentiometer,IC Socket,Relay,Connector.Our parts cover such applications as commercial,industrial, and automotives areas.

We are looking forward to setting up business relationship with you and hope to provide you with the best service and solution. Let us make a better world for our industry!



## Contact us

Tel: +86-755-8981 8866 Fax: +86-755-8427 6832

Email & Skype: info@chipsmall.com Web: www.chipsmall.com

Address: A1208, Overseas Decoration Building, #122 Zhenhua RD., Futian, Shenzhen, China



## IBS IL 24 RB-LK (-2MBD)

**Inline Branch Terminal  
for an INTERBUS Remote Bus;  
Connections Using Fiber Optics**

### AUTOMATIONWORX

#### Data Sheet

© PHOENIX CONTACT - 08/2005

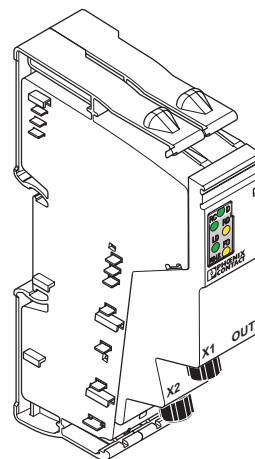

#### Description

The branch terminal is designed for use within an Inline station. The terminal offers the possibility of expanding the INTERBUS network by additional system levels. In total up to 15 levels can be operated in the network.

Snapping on the branch terminal to an INTERBUS bus coupler, a control terminal or a branch terminal opens a remote bus branch at this preconnected terminal. The IBS IL 24 RB-LK (-2MBD) terminal is the first terminal in the remote bus branch.

The branch terminal has an outgoing fiber optic remote bus interface and a combined remote bus branch/local bus interface (Inline data jumper) additionally. If an additional branch terminal (IBS IL 24 RB-LK or IBS IL 24 RB-T) is snapped onto this interface, it opens a remote bus branch. If any other device is snapped on, the interface opens a local bus.

The functions of the IBS IL 24 RB-LK and IBS IL 24 RB-LK-2MBD terminals are identical. The essential difference between them is the transmission speed.

IBS IL 24 RB-LK: 500 kBaud

IBS IL 24 RB-LK-2MBD: 2 MBaud

Further differing technical data are particularly identified. For greater clarity, the designation IBS IL 24 RB-LK is used throughout this document.



This data sheet is only valid in association with the "Configuring and Installing the INTERBUS Inline Product Range" user manual IB IL SYS PRO UM E.



Please note the "Configuration Notes" on page 5 to avoid configuration errors.



Make sure you always use the latest documentation.  
It can be downloaded at [www.download.phoenixcontact.com](http://www.download.phoenixcontact.com).  
A conversion table is available on the Internet at  
[www.download.phoenixcontact.com/general/7000\\_en\\_00.pdf](http://www.download.phoenixcontact.com/general/7000_en_00.pdf).



This data sheet is valid for the terminals listed under "Ordering Data" on page 11.

## Local Diagnostic and Status Indicators and Remote Bus Connections

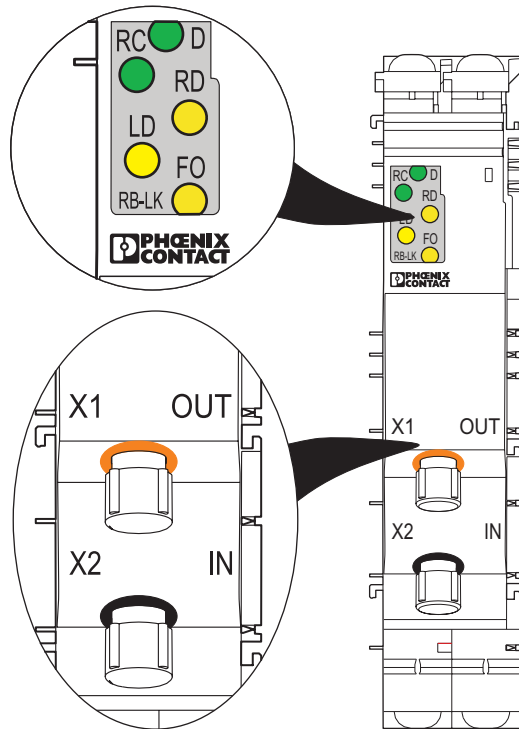

7181A002

Figure 1 Local diagnostic and status indicators and remote bus connections

### Local Diagnostic Indicators

Des.	Color	Meaning
<b>D</b>	Green	Diagnostics
<b>RC</b>	Green	Remote bus cable check
<b>RD</b>	Yellow	Remote bus disabled
<b>LD</b>	Yellow	Remote bus branch/local bus disconnected
<b>LD</b>	Red	Isolated disconnection of remote bus branch/local bus disconnected after error
<b>FO</b>	Yellow	Status of the outgoing fiber optic path

**RD ON:** The fiber optic remote bus is disabled.

Possible causes:

- This interface or a preconnected interface has been switched off.
- INTERBUS is not running (is not in the RUN state).



If, in the event of an error, the preconnected bus terminal disconnects its remote bus branch/local bus interface in isolation, the RD and LD LEDs light up on this RB-LK.



For the function description of all other LEDs, please refer to the "Configuring and Installing the INTERBUS Inline Product Range" user manual.

### Remote Bus Connections

Designation	Connection
X1 OUT	Transmit data of outgoing remote bus
X2 IN	Receive data of outgoing remote bus

### Function Identification

Gray

2 MBaud: white stripe in the vicinity of the D LED

## Connecting the Remote Bus Cables

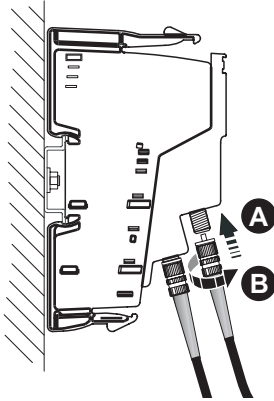

Figure 2 Connecting the remote bus cables



Please refer to the Fiber Optic Installation Guidelines DB EN IBS SYS FOC ASSEMBLY (Part No. 94 23 43 9) when assembling optical fibers.

Connect the fiber optic remote bus cable to the terminal using F-SMA connectors.

- Fit the corresponding F-SMA connectors to the fiber optic cables.
- Place the connectors into the appropriate connections.
- Secure the connections with the cap nuts.



The label for the fiber optic connections (black/orange) corresponds to the color of the fiber optics for the polymer fiber cable, which are specified under "Fiber Optic Interface" on page 10. Connect the individual fiber optic cables between adjacent terminals according to their color (e.g., orange cable to orange connections).

## Internal Circuit Diagram

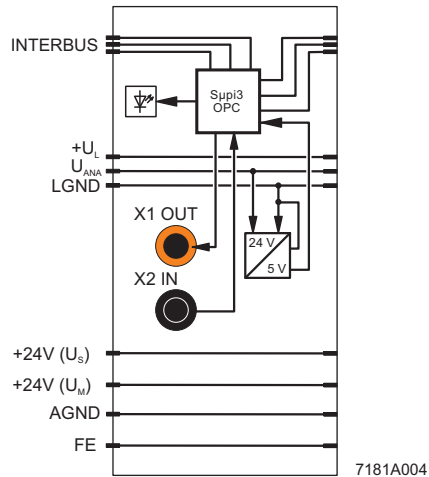

Figure 3 Internal circuit diagram

Key:



LED



INTERBUS protocol chip (bus logic including voltage conditioning)



Fiber optic connections



Power supply unit with electrical isolation



Other symbols used are explained in the IBS IL SYS PRO UM E user manual.

### Connection Example

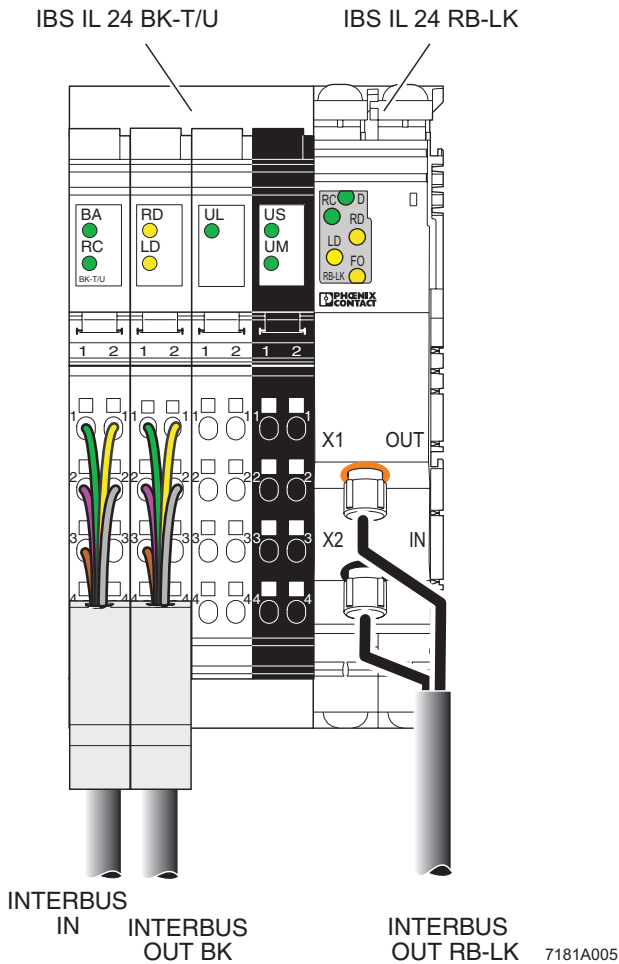



Figure 4 Typical connection of the INTERBUS cables

- INTERBUS IN Incoming remote bus
- INTERBUS OUT BK Outgoing remote bus BK-T/U
- INTERBUS OUT RB-LK Outgoing remote bus RB-LK

 In terms of topology, the remote bus branch, which is opened at the IBS IL 24 BK-T/U, is located between the bus coupler and the branch terminal (B in Figure 5).

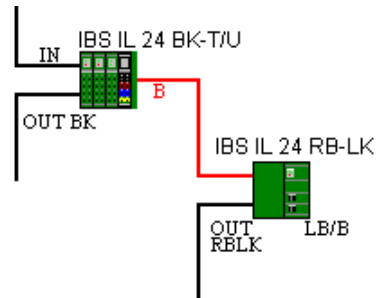

Figure 5 Bus coupler/branch terminal topology

- IN Incoming remote bus
- OUT BK Outgoing remote bus BK-T/U
- B Remote bus branch (internal interface)
- OUT RBLK Outgoing remote bus RB-LK
- LB/B **Local bus** (LB; in the event of subsequent I/O terminals) **or Remote bus branch** (B; in the event of a subsequent branch terminal)

### Configuration Notes



When working on an INTERBUS system, only use **one** transmission speed (500 kBaud or 2 MBaud).

The IBS IL 24 RB-LK branch terminal can only be installed directly after a bus coupler, a control terminal or a branch terminal (e.g., IBS IL 24 RB-LK).



This means that no INTERBUS device (terminal with protocol chip) must be present between the preconnected terminal and the relevant branch terminal. Power terminals or segment terminals without protocol chip (e.g., IB IL 24 PWR IN) may be present between the preconnected terminal and the relevant branch terminal.

You can use up to **15 branch terminals** after the bus couplers and control terminals from the current Phoenix Contact catalog.



Observe the restrictions and notes provided in the terminal-specific data sheet for you particular application.

#### Restrictions/Special Features:

##### IBS IL 24 BK-T (discontinued item)

Only use **one** IBS IL 24 RB-LK branch terminal in an Inline station with an IBS IL 24 BK-T.

##### ILC 350 ETH / ILC 370 ETH-IB

In terms of topology, the **first** branch terminal after the Inline Controller opens a **remote bus**.

If **additional branch terminals** are used after the first branch terminal, these branches topologically are **remote bus branches** with the branch terminal being the first device in the relevant remote bus branch.

### Isolated Connection and Disconnection



Please note that isolated connection and disconnection in the event of an error is only possible with remote bus branch and local bus interfaces. Isolated connection and disconnection in the event of an error is not possible with an outgoing remote bus interface.

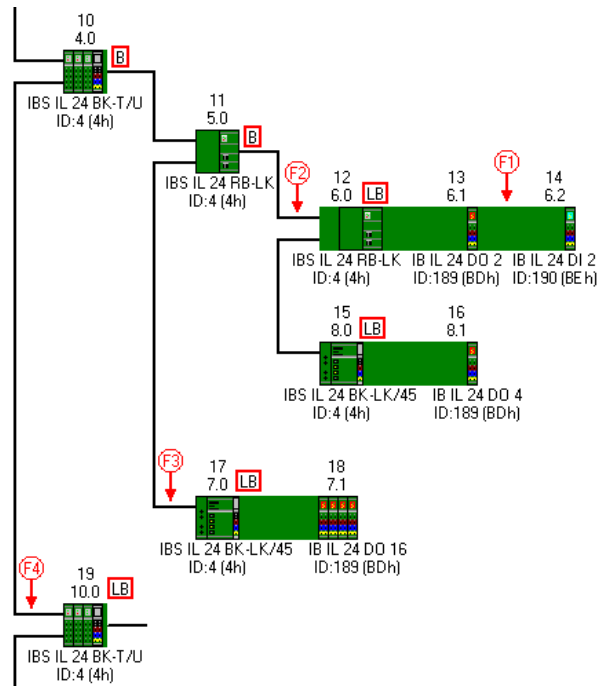

Figure 6 Example for isolated connection and disconnection in the event of an error

You can parameterize isolated connection and disconnection in the event of an error on all shown bus couplers and branch terminals.

Isolated disconnection in the event of an error is performed at the following positions:

- B** (Remote bus branch): **Remote bus branch**
- LB** (Local bus): **Local bus**

The following happens if the corresponding error occurs:

#### F1: Error in the local bus of an Inline station:

The local bus interface is disconnected in isolation at the preconnected branch terminal (parameterized for this purpose) or the preconnected bus coupler (parameterized for this purpose).

**Example F1:** Error on local bus of station 6:  
Local bus interface of the branch terminal 6.0 is disconnected. The entire bus continues to run except for the local bus disconnected (6.1, 6.2).

**F2/F3: Error on a remote bus branch or a remote bus topologically located in a branch:**

The remote bus branch interface is disconnected in isolation at the preconnected branch terminal (parameterized for this purpose) or the preconnected bus coupler (parameterized for this purpose).

**Example F2:**

Error between **5.0 and 6.0** (remote bus branch) or error between **6.0 and 8.0** (remote bus topologically located in a branch):

The remote bus branch interface at 5.0 is disconnected in isolation. This disconnects **devices 6.x and 8.x**.

**Example F3:**

Error between **5.0 and 7.0** (remote bus topologically located in a branch):

The remote bus branch interface at 4.0 is disconnected in isolation. This disconnects devices 5.0, 6.x, 8.x and 7.x.

**F4: Error on remote bus:**

Isolated disconnection of an outgoing remote bus interface is not possible in the event of an error. A bus error causes a bus failure.

**Example F4:**

Error between 4.0 and 10.0:  
Bus error which causes bus failure.

## Programming Data

ID code	04 <sub>hex</sub> (04 <sub>dec</sub> )
Length code	00 <sub>hex</sub>
Input address area	0 bytes
Output address area	0 bytes
Parameter channel (PCP)	0 bytes
Register length (bus)	0 bytes

## Technical Data

### General Data

Housing dimensions (width x height x depth)	24.4 mm x 120 mm x 71.5 mm
Weight	89 g
Permissible temperature (operation)	-25°C to +55°C
Permissible temperature (storage/transport)	-25°C to +85°C
Permissible humidity (operation)	75% on average, 85% occasionally



In the range from - 25°C to + 55°C appropriate measures against increased humidity (> 85%) must be taken.

Permissible humidity (storage/transport)	75% on average, 85% occasionally
--	----------------------------------



For a short period, slight condensation may appear on the outside of the housing if, for example, the terminal is brought into a closed room from a vehicle.

Permissible air pressure (operation)	80 kPa to 106 kPa (up to 2000 m above sea level)
Permissible air pressure (storage/transport)	70 kPa to 106 kPa (up to 3000 m above sea level)
Degree of protection	IP20 according to IEC 60529
Class of protection	Class 3 according to VDE 0106, IEC 60536

### Interfaces (INTERBUS)

#### Remote Bus

Incoming remote bus	Through data routing
Outgoing remote bus	Polymer fiber 980 µm/1000 µm; HCS fiber 200 µm/230 µm Connection using F-SMA connector



The IBS IL 24 RB-LK does not count as an Inline station device (63, maximum).

Remote bus branch/local bus	Through data routing
Recommended cable lengths	See INTERBUS system data

#### Local Bus

Connection	Through data routing
Level	5 V CMOS signal level
Number of Inline terminals that can be connected	
Limitation through software	63, maximum
Limitation through power supply unit	
– Maximum current consumption of the connected local bus modules at the communications power:	$I_{\max} \leq 2 \text{ A DC}$
– Maximum current consumption of the connected local bus modules at the analog supply:	$I_{\max} \leq 0.5 \text{ A}$



#### Observe current consumption of the terminals

Observe the current consumption of each device when configuring an Inline station! It is specified in every terminal-specific data sheet. The current consumption can differ depending on the individual terminal. The permissible number of devices that can be connected therefore depends on the specific station structure.



**Transmission Speed**

IBS IL 24 RB-LK	500 kBaud
IBS IL 24 RB-LK-2MBD	2 MBaud

**Power Consumption (IBS IL 24 RB-LK)**

Communications power $U_L$	–
Current consumption from $U_L$	–
Power consumption from $U_L$	–
Analog supply voltage $U_{ANA}$	24 V DC (nominal value)
Nominal current consumption at $U_{ANA}$	42 mA (nominal value); 51 mA (maximum; at $U_{ANA} = 19.2$ V)
Power consumption from $U_{ANA}$	1.00 W (nominal value); 1.05 W (maximum; at $U_{ANA} = 30.0$ V)

**Power Consumption (IBS IL 24 RB-LK-2MBD)**

Communications power $U_L$	–
Current consumption from $U_L$	–
Power consumption from $U_L$	–
Analog supply voltage $U_{ANA}$	24 V DC (nominal value)
Nominal current consumption at $U_{ANA}$	47 mA (nominal value); 57 mA (maximum; at $U_{ANA} = 19.2$ V)
Power consumption from $U_{ANA}$	1.13 W (nominal value); 1.20 W (maximum; at $U_{ANA} = 30.0$ V)

**Supply of the Module Electronics Through the Bus Coupler ( $U_{ANA}$ )**

Connection method	Through potential routing
-------------------	---------------------------

**Power Dissipation****Formula to Calculate the Power Dissipation of the Electronics**

$$P_{EL} = U_{ANA} \times I_{TOT}$$

Where

$P_{EL}$	Total power dissipation in the terminal
$U_{ANA}$	Analog voltage
$I_{TOT}$	Total current consumption in the branch terminal at $U_{ANA}$

Example:

$$P_{EL} = 24 \text{ V} \times 42 \text{ mA}$$

$$P_{EL} = 1.008 \text{ W}$$

**Power Dissipation of the Housing  $P_{HOU}$** 

$P_{HOU} = 1.2$  W in the total permissible ambient temperature range

**Derating**

Up to an ambient temperature of 55°C	For this temperature range, insert at least one Inline terminal that is not an INTERBUS device (e.g., segment/power terminal without protocol chip) between bus coupler/controller and the first IBS IL 24 RB-LK.
Up to an ambient temperature of 50°C	No restrictions

**Error Messages to the Higher-Level Control or Computer System**

None

**Safety Equipment**

None

**Electrical Isolation/Isolation of the Voltage Areas****Common Potentials**

The 7.5 V communications power, 24 V analog supply, 24 V bus coupler supply, and 5 V communications power of the branch terminal share a common potential.

**Separate Potentials**

The communications power ground is jumpered to the ground of the 7.5 V communications power for the bus coupler power supply unit.

The I/O supply is always electrically isolated from the interface supplies.

**Electrical Isolation/Isolation of the Voltage Areas When Combining a Bus Coupler and the IBS IL 24 RB-LK Branch Terminal****Test Distance****Test Voltage****5 V supply of incoming remote bus (bus coupler) electrically isolated from**

5 V supply of outgoing remote bus (bus coupler)

500 V AC, 50 Hz, 1 min

7.5 V communications power, 24 V analog supply, 24 V bus coupler supply, 5 V communications power of branch terminal

500 V AC, 50 Hz, 1 min

24 V main supply, 24 V segment supply

500 V AC, 50 Hz, 1 min

Functional earth ground

500 V AC, 50 Hz, 1 min

**5 V supply of outgoing remote bus (bus coupler) electrically isolated from**

5 V supply of incoming remote bus (bus coupler)

500 V AC, 50 Hz, 1 min

7.5 V communications power, 24 V analog supply, 24 V bus coupler supply, 5 V communications power of branch terminal

500 V AC, 50 Hz, 1 min

24 V main supply, 24 V segment supply

500 V AC, 50 Hz, 1 min

Functional earth ground

500 V AC, 50 Hz, 1 min

**7.5 V communications power, 24 V analog supply, 24 V bus coupler supply, 5 V communications power of branch terminal electrically isolated from**

5 V supply of incoming remote bus (bus coupler)

500 V AC, 50 Hz, 1 min

5 V supply of outgoing remote bus (bus coupler)

500 V AC, 50 Hz, 1 min

24 V main supply, 24 V segment supply

500 V AC, 50 Hz, 1 min

Functional earth ground

500 V AC, 50 Hz, 1 min

**24 V main supply, 24 V segment supply electrically isolated from**

5 V supply of incoming remote bus (bus coupler)

500 V AC, 50 Hz, 1 min

5 V supply of outgoing remote bus (bus coupler)

500 V AC, 50 Hz, 1 min

7.5 V communications power, 24 V analog supply, 24 V bus coupler supply, 5 V communications power of branch terminal

500 V AC, 50 Hz, 1 min

Functional earth ground

500 V AC, 50 Hz, 1 min



<b>Fiber Optic Interface</b>			
	<b>Polymer Fibers</b>		<b>HCS Fibers</b>
Minimum optical output power at 25°C (control level 15)	> -5.3 dBm		>-16.0 dBm, typical
Maximum optical output power at 25°C (control level 15)	-3.0 dBm		-9.0 dBm
Laser protection class according to DIN EN 60825-1:1994 + A11:1996	1		1
Minimum optical power at 25°C after module power up (control level 14)	> -6.8 dBm		>-17.5 dBm, typical
Optical output power (-25°C to 55°C) (control level 15)	> -6.2 dBm		> -16.9 dBm, typical
Minimum optical receiver responsivity (-25°C to 55°C)	< -21.6 dBm		< -23.0 dBm
Optical overrange at 25°C	> -2.0 dBm		> -4.0 dBm
<b>Available attenuation (-25°C to 55°C)</b>	<b>&gt; 15.4 dB</b>		<b>&gt; 6.1 dB</b>
Maximum wavelength (-25°C to 55°C)	660 nm		660 nm
System reserve	3 dB		3 dB
<b>Available attenuation for optical fibers (-25°C to 55°C)</b>	<b>&gt; 12.4 dB</b>		<b>&gt; 3.1 dB</b>
Cable type	PSM-LWL-RUGGED; PSM-LWL-KDHEAVY	PSM-LWL-RUGGED-FLEX	PSM-LWL-HCS
Maximum attenuation at 660 nm LED measurement	230 dB/km	280 dB/km	10 dB/km
Typical attenuation at 660 nm LED measurement	200 dB/km	250 dB/km	8 dB/km
Guaranteed maximum transmission distance	50 m	35 m	> 100 m (300 m, typical)

## Ordering Data

### Terminals

Description	Order Designation	Order No.	Pcs./Pkt.
Inline branch terminal for an INTERBUS remote bus; connections using fiber optics; transmission speed: 500 kBaud	IBS IL 24 RB-LK	28 78 11 7	1
Inline branch terminal for an INTERBUS remote bus; connections using fiber optics; transmission speed: 2 MBaud	IBS IL 24 RB-LK-2MBD	28 78 15 9	1

### Accessories

Description	Order Designation	Order No.	Pcs./Pkt.
 Four F-SMA connectors are required for connecting INTERBUS.			
F-SMA connector set for polymer fibers, for self-assembly, consisting of four quick mountable connectors with bending protection	PSM-SET-FSMA/4-KT	27 99 72 0	1
F-SMA connector set for HCS fibers, for self-assembly, consisting of four quick mountable connectors with bending protection	PSM-SET-FSMA/4-HCS	27 99 48 7	1
 Ordering data for fiber optic cables and additional accessories for assembling fiber optic cables can be found in the "INTERFACE" catalog.			

### Documentation

Description	Order Designation	Order No.
"Configuring and Installing the INTERBUS Inline Product Range" user manual	IB IL SYS PRO UM E	27 43 04 8
Fiber Optic Installation Guidelines	DB GB IBS SYS FOC ASSEMBLY	94 23 43 9

© PHOENIX CONTACT 08/2005