



Chipsmall Limited consists of a professional team with an average of over 10 year of expertise in the distribution of electronic components. Based in Hongkong, we have already established firm and mutual-benefit business relationships with customers from,Europe,America and south Asia,supplying obsolete and hard-to-find components to meet their specific needs.

With the principle of “Quality Parts,Customers Priority,Honest Operation,and Considerate Service”,our business mainly focus on the distribution of electronic components. Line cards we deal with include Microchip,ALPS,ROHM,Xilinx,Pulse,ON,Everlight and Freescale. Main products comprise IC,Modules,Potentiometer,IC Socket,Relay,Connector.Our parts cover such applications as commercial,industrial, and automotives areas.

We are looking forward to setting up business relationship with you and hope to provide you with the best service and solution. Let us make a better world for our industry!



Contact us

Tel: +86-755-8981 8866 Fax: +86-755-8427 6832

Email & Skype: info@chipsmall.com Web: www.chipsmall.com

Address: A1208, Overseas Decoration Building, #122 Zhenhua RD., Futian, Shenzhen, China



ILB IB 24 DI16-DSUB

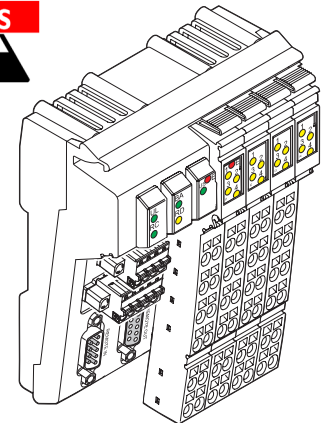

**Inline Block IO Module
for INTERBUS With 16 Digital Inputs;
Bus Connection via D-SUB Connectors**

AUTOMATIONWORX

Data Sheet
7118_en_02

© PHOENIX CONTACT - 03/2007

Description

The ILB IB 24 DI16-DSUB module is designed for use within an INTERBUS network. It is used to acquire digital signals.

INTERBUS Features

- Remote bus connection via D-SUB connector
- 500 kbps transmission speed
- Diagnostic and status indicators

Input Features

- Connections for 16 digital sensors
- Connection of sensors in 2 and 3-wire technology
- Maximum permissible load current per sensor: 125 mA
- Maximum permissible load current from the sensor supply: 2.0 A
- Diagnostic and status indicators



Please refer to the "Mounting and Removing Inline Block IO Modules" application note (see "Ordering Data" on page 2).



Make sure you always use the latest documentation.
It can be downloaded at www.download.phoenixcontact.com.

A conversion table is available on the Internet at
www.download.phoenixcontact.com/general/7000_en_00.pdf.

Ordering Data

Product

Description	Type	Order No.	Pcs./Pkt.
Inline Block IO module for INTERBUS with 16 digital inputs; bus connection via D-SUB connectors	ILB IB 24 DI16-DSUB	2878421	1

Accessories: Connectors

Description	Type	Order No.	Pcs./Pkt.
D-SUB connector (female connector), solder connection	SUBCON 9/F-SH	2761499	1
D-SUB connector (male connector), solder connection	SUBCON 9/M-SH	2761509	1

Accessories: Connectors as Replacement Item

Description	Type	Order No.	Pcs./Pkt.
Connector for the supply (4-pos. MINI COMBICON)	FK-MCP 1,5/5-STF-3,81	1851258	50
Connector for the supply (5-pos. MINI COMBICON)	FK-MCP 1,5/6-STF-3,81	1851261	50
Connector for digital 4-channel or 16-channel Inline input terminals, with color print	IB IL SCN-12-ICP	2727611	10

Accessories: Other

Description	Type	Order No.	Pcs./Pkt.
Recommended end clamp; placed both to the right and left of the module to secure it on the DIN rail	CLIPFIX 35-5	3022276	50

Documentation

Description	Type	Order No.	Pcs./Pkt.
"Mounting and Removing Inline Block IO Modules" application note	AH ILB INSTALLATION	9014931	1
"INTERBUS Addressing" data sheet	DB GB IBS SYS ADDRESS	9000990	1
"Addressing of 16-Channel ILB Modules" application note	AH ILB 24 DI/DO 16 ADDRESS	9014962	1
"General Introduction to the INTERBUS System" user manual	IBS SYS INTRO G4 UM E	2745211	1
"Configuring and Installing INTERBUS" user manual	IBS SYS PRO INST UM E	2743802	1

Technical Data

General Data

Housing dimensions with connectors (width x height x depth)	95 mm x 55 mm x 141 mm
Weight	254 g (with connectors)
Operating mode	Process data mode with 1 word
Transmission speed	500 kbps
Connection method for sensors	2 and 3-wire technology

Housing Dimensions

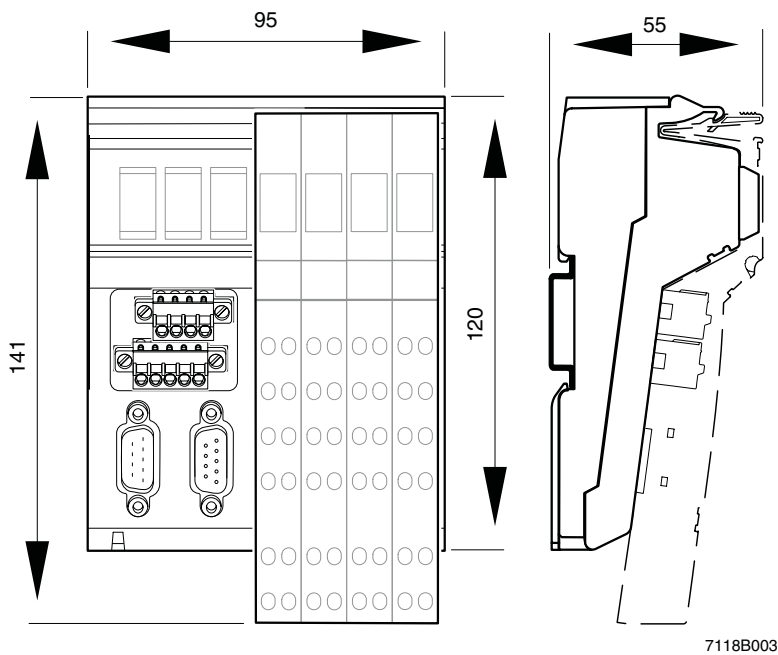

Figure 1 Housing dimensions of the module (dimensions in mm)

Ambient Conditions

Regulations	Developed according to VDE 0160/EN 50178/IEC 62103, UL 508
Ambient temperature (operation)	-25°C to +60°C
Ambient temperature (storage/transport)	-25°C to +85°C
Humidity (operation/storage/transport)	10% to 95%, according to EN 61131-2
Air pressure (operation)	80 kPa to 108 kPa (up to 2000 m above sea level)
Air pressure (storage/transport)	66 kPa to 108 kPa (up to 3500 m above sea level)
Degree of protection according to IEC 60529	IP20
Class of protection	Class 3 according to VDE 0106/IEC 60536
Air and creepage distances	According to DIN VDE 0110/IEC 60664, IEC 60664A, DIN VDE 0160/EN 50178/IEC 62103
Housing material	Plastic, PVC-free, PBT, self-extinguishing (V0)
Pollution degree according to EN 60664-1/IEC 60664-1, EN 61131-2/IEC 61131-2	2; condensation not permitted during operation
Surge voltage class	II

Electrical Isolation/Isolation of the Voltage Areas

Test Distance	Test Voltage
Incoming remote bus / outgoing remote bus	500 V AC, 50 Hz, 1 min
Incoming remote bus / I/O	500 V AC, 50 Hz, 1 min
Incoming remote bus / functional earth ground	500 V AC, 50 Hz, 1 min
Outgoing remote bus / I/O	500 V AC, 50 Hz, 1 min
Outgoing remote bus / functional earth ground	500 V AC, 50 Hz, 1 min
I/O / functional earth ground	500 V AC, 50 Hz, 1 min

Mechanical Requirements

Vibration test, sinusoidal vibrations according to EN 60068-2-6/IEC 60068-2-6	5g load, 2.5 hours in each space direction
Shock test according to EN 60068-2-27/IEC 60068-2-27	25g load for 11 ms, half sinusoidal wave, 3 shocks in each space direction and orientation
Broadband noise according to EN 60068-2-64/IEC 60068-2-64	0.78g load, 2.5 hours in each space direction

Conformance With EMC Directive 89/336/EEC

Noise Immunity Test According to EN 61000-6-2

Electrostatic discharge (ESD)	EN 61000-4-2 IEC 61000-4-2	Criterion B 6 kV contact discharge 8 kV air discharge
Electromagnetic fields	EN 61000-4-3 IEC 61000-4-3	Criterion A Field strength: 10 V/m
Fast transients (burst)	EN 61000-4-4/ IEC 61000-4-4	Criterion B Remote bus: 2 kV Power supply: 2 kV I/O cables: 2 kV Criterion A All interfaces: 1 kV
Surge voltage	EN 61000-4-5 IEC 61000-4-5	Criterion B DC supply lines: ± 0.5 kV/± 1.0 kV (symmetrical/asymmetrical) Signal lines: ± 0.5 kV/± 0.5 kV (symmetrical/asymmetrical)
Conducted interference	EN 61000-4-6 IEC 61000-4-6	Criterion A Test voltage 10 V

Noise Emission Test According to EN 61000-6-4

Noise emission of housing	EN 55022	Class B (residential)
---------------------------	----------	-----------------------

Interface: INTERBUS

Incoming remote bus	Copper cable (RS-422), connected via 9-pos. D-SUB connector; supply electrically isolated; shielding connected with a capacitor to functional earth ground
Outgoing remote bus	Copper cable (RS-422), connected via 9-pos. D-SUB connector; supply electrically isolated; shielding directly connected to functional earth ground
Recommended cable lengths	See INTERBUS system data in the IBS SYS INTRO G4 UM E user manual

24 V Module Supply (Communications Power and Sensor Supply; U_L and U_S)

Nominal value	24 V DC
Tolerance	-15%/+20% according to EN 61131-2
Ripple	±5% according to EN 61131-2
Permissible range	19.2 V DC to 30.0 V DC
Current consumption at U _L	60 mA
Current consumption at U _S	4 A
Safety equipment for communications power	Surge protection and protection against polarity reversal
Safety equipment for sensor supply	Surge, overload and short-circuit protection
Connection	Via MINI-COMBICON connector

Digital Inputs

Number	16
Connection method for sensors	2 and 3-wire technology
Input design	According to EN 61131-2 Type 1
Definition of switching thresholds	
Maximum low-level voltage	U _{Lmax} < 5 V
Minimum high-level voltage	U _{Hmin} > 15 V
Common potentials	Sensor supply U _S , ground
Nominal input voltage U _{IN}	24 V DC
Permissible range	-30 V < U _{IN} < +30 V DC
Nominal input current for U _{IN}	5 mA, typical
Current flow	Linear in the range 1 V < U _{IN} < 30 V
Delay time	≤ 500 μs
Permissible cable length to the sensor	100 m
Use of AC sensors	AC sensors in the voltage range < U _{IN} are limited in application

Power Dissipation

Formula to Calculate the Power Dissipation of the Electronics

$P_{TOT} = 1.44 \text{ W} + I_S^2 \times 0.06 \text{ W} + \sum_{i=1}^n 0.12 \text{ W}$	<p>Where</p> <p>P_{TOT} Total power dissipation of the module</p> <p>I_S Current from the sensor supply</p> <p>i Continuous index</p> <p>n Number of set inputs (n = 1 to 16)</p>
--	---

Limitation of Simultaneity, Derating

No limitation of simultaneity, no derating

Approvals

For the latest approvals, please visit www.download.phoenixcontact.com.

Internal Circuit Diagram

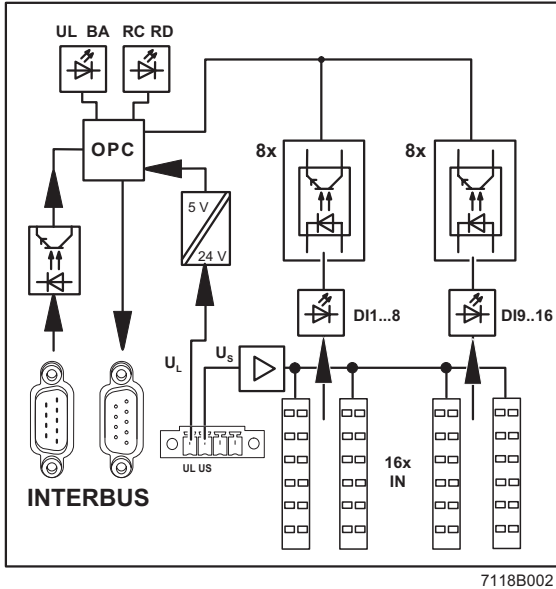







Figure 2 Internal wiring of the terminal points

Key:

-  LED
-  Protocol chip (bus logic)
-  Power supply unit with electrical isolation
-  Optocoupler
-  Short-circuit-proof sensor supply

Local Diagnostic and Status Indicators

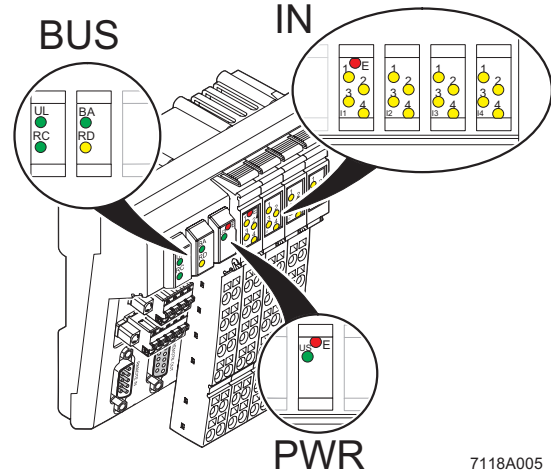

Figure 3 Diagnostic and status indicators of the ILB IB 24 DI16-DSUB module

Designation	Color	Meaning
BUS		
UL	Green	Communications power
RC	Green	Remote bus cable check
BA	Green	Bus active
RD	Yellow	Outgoing remote bus disabled
PWR		
E	Red	Undervoltage of the sensor supply U_S
US	Green	Sensor supply
IN		
E	Red	Short circuit or overload of the sensor supply
1 to 4	Yellow	Status indicators of the inputs

Connecting INTERBUS, the Supply, and Sensors

Terminal Point Assignment of the MINI-COMBICON Connectors for the Connection of the Supply Voltages (Connectors X1 and X2 in Figure 4 on page 7).

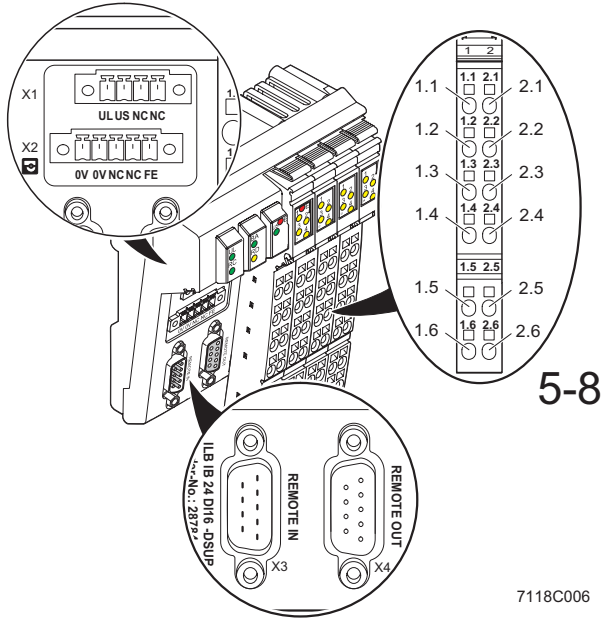

Figure 4 Terminal point assignment of the connectors

Terminal Point	Assignment
UL	24 V communications power U_L
US	24 V sensor supply U_S
NC	Not used
NC	Not used

Terminal Point	Assignment
0V	GND
0V	GND
NC	Not used
NC	Not used
FE	Functional earth ground



The terminal points for GND (0V) can have a total current of 8 A per terminal point. The maximum current carrying capacity of 8 A must not be exceeded.



The supply points have the same ground potential. All ground supplies on a module are electrically connected with one another. The communications power is also electrically connected via all contacts. In this way it can supply all potentials with just one supply without the need for additional terminals, see "Connection example" on page 9.

Terminal Point Assignment of the INTERBUS Connectors (Connectors X 3 and X4 in Figure 4 on page 7)

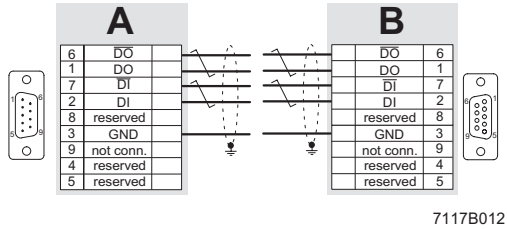

7117B012

Figure 5 Assignment of the remote bus interfaces (D-SUB connector)

- A Remote OUT (outgoing remote bus)
- B Remote IN (incoming remote bus)

Assignment	Remark/Wire Color in the INTERBUS Standard Cable	
DO	Receive	Green
DO	Receive	Yellow
DI	Transmit	Pink
DI	Transmit	Gray
GND	Reference potential	Brown
Shield (incoming remote bus)	Shield potential is connected with a capacitor to functional earth ground (FE) of the potential jumper.	
Shield (outgoing remote bus)	Shield potential is directly connected to functional earth ground (FE) of the potential jumper.	



In order to assemble the connectors, proceed as described in the IBS SYS PRO INST UM E user manual.

Terminal Point Assignment of the Input Connectors (Connectors 5 to 8 in Figure 4 on page 7)

Terminal Point				Assignment
Connector 5 (I1)	Connector 6 (I2)	Connector 7 (I3)	Connector 8 (I4)	
1.1, 2.1	1.1, 2.1	1.1, 2.1	1.1, 2.1	Signal input (IN)
1.2, 2.2	1.2, 2.2	1.2, 2.2	1.2, 2.2	Sensor supply for 2 and 3-wire termination
1.3, 2.3	1.3, 2.3	1.3, 2.3	1.3, 2.3	Ground contact (GND) for 3-wire termination
1.4, 2.4	1.4, 2.4	1.4, 2.4	1.4, 2.4	Signal input (IN)
1.5, 2.5	1.5, 2.5	1.5, 2.5	1.5, 2.5	Sensor supply for 2 and 3-wire termination
1.6, 2.6	1.6, 2.6	1.6, 2.6	1.6, 2.6	Ground contact (GND) for 3-wire termination

Connection Example

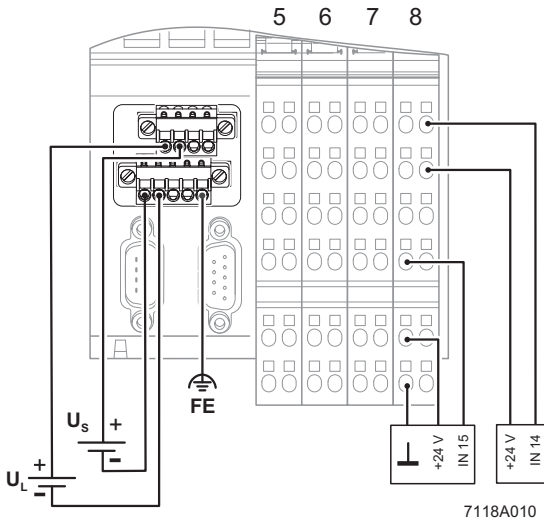

Figure 6 Connection example



The numbers above the module illustration identify the connector slots.



When connecting the sensors observe the assignment of the terminal points to the process data (see "Process Data" on page 10).



The module has an FE spring (metal clip) on the bottom of the electronics base. This spring creates an electrical connection to the DIN rail. Use grounding terminals to connect the DIN rail to protective earth ground. The module is grounded when it is snapped onto the DIN rail. To ensure reliable functional earth grounding of the module even when the DIN rail is dirty or the metal clip is damaged, Phoenix Contact also recommends grounding the module via one of the FE terminal points.

Programming Data

ID code	02 _{hex} (02 _{dec})
Length code	01 _{hex}
Process data channel	16 bits
Input address area	1 word
Output address area	0 words
Parameter channel (PCP)	0 words
Register length (bus)	1 word

Process Data



For the assignment of the illustrated (byte.bit) view to your control or computer system, please refer to the DB GB IBS SYS ADDRESS data sheet.
 Please refer to the application note for addressing 16-channel ILB modules.
 The documentation can be downloaded at www.download.phoenixcontact.com.

Assignment of the Terminal Points to the IN Process Data Word (Slots 5 to 8)

(Word.bit) view	Word	Word 0															
	Bit	15	14	13	12	11	10	9	8	7	6	5	4	3	2	1	0
(Byte.bit) view	Byte	Byte 0								Byte 1							
	Bit	7	6	5	4	3	2	1	0	7	6	5	4	3	2	1	0
Module	Slot	6 (I2)				5 (I1)				8 (I4)				7 (I3)			
	Terminal point (signal)	2.4	1.4	2.1	1.1	2.4	1.4	2.1	1.1	2.4	1.4	2.1	1.1	2.4	1.4	2.1	1.1
	Terminal point (+24 V)	2.5	1.5	2.2	1.2	2.5	1.5	2.2	1.2	2.5	1.5	2.2	1.2	2.5	1.5	2.2	1.2
	Terminal point (GND)	2.6	1.6	2.3	1.3	2.6	1.6	2.3	1.3	2.6	1.6	2.3	1.3	2.6	1.6	2.3	1.3
Status indicator	Slot	6				5				8				7			
	LED	4	3	2	1	4	3	2	1	4	3	2	1	4	3	2	1

Diagnostics

Error Table With Diagnostic Data and Status Indicators

Error Type	Diagnostic Data	Status Indicators
Sensor voltage U_S too low	I/O error message	US LED is OFF E (PWR) LED is red
Sensor supply short circuit	I/O error message	E (IN) LED of the sensor supply is red