



Chipsmall Limited consists of a professional team with an average of over 10 year of expertise in the distribution of electronic components. Based in Hongkong, we have already established firm and mutual-benefit business relationships with customers from,Europe,America and south Asia,supplying obsolete and hard-to-find components to meet their specific needs.

With the principle of "Quality Parts,Customers Priority,Honest Operation,and Considerate Service",our business mainly focus on the distribution of electronic components. Line cards we deal with include Microchip,ALPS,ROHM,Xilinx,Pulse,ON,Everlight and Freescale. Main products comprise IC,Modules,Potentiometer,IC Socket,Relay,Connector.Our parts cover such applications as commercial,industrial, and automotives areas.

We are looking forward to setting up business relationship with you and hope to provide you with the best service and solution. Let us make a better world for our industry!



## Contact us

Tel: +86-755-8981 8866 Fax: +86-755-8427 6832

Email & Skype: info@chipsmall.com Web: www.chipsmall.com

Address: A1208, Overseas Decoration Building, #122 Zhenhua RD., Futian, Shenzhen, China



# IB IL SGI 2/P-PAC

Inline analog strain gauge input terminal,  
two precise inputs, 4, 6-wire connection method

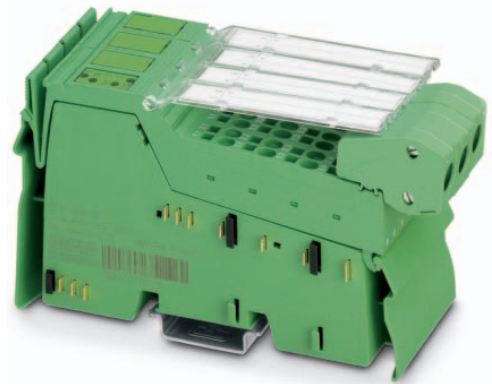

Data sheet  
7647\_en\_04

© PHOENIX CONTACT 2013-01-17

## 1 Description

The terminal is designed for use within an Inline station.

This terminal provides a precision input module to connect weighing cells, force transducers, mass force transducers and comparable, based on the strain gauges.

The strain gauges can be connected using 6 or 4-wire technology.

Thanks to a serial interface the measured value can be output directly on a weight display.

There are two options for data exchange:

- Via process data
- Via PCP (both inputs in the "Analog Values" PCP object)

The measured values are represented by standardized 16-bit values.

### Features

- Two high-precision inputs for the strain gauges
- Measuring ranges adjusted with nominal characteristic values upon delivery  $\pm 1$  mV/V,  $\pm 2$  mV/V,  $\pm 3$  mV/V,  $\pm 3.33$  mV/V,  $\pm 4$  mV/V and  $\pm 5$  mV/V
- Path adjustment in the process environment
- Connection of the strain gauges with 6- and 4-wire technology
- Sensor supply voltage provided by the terminal, no external power supply required
- For each channel: Low-resistance, floating N/O contact for the 80% calibration (shunt calibration)
- Serial interface for external weight displays
- Channels are configured independently of one another using the bus system.
- Tare weight adjustment
- Status message when zero point is reached and resting of measured value
- Diagnostic indicators
- Hardware version 01 or later:  
Approved for use in zone 2 potentially explosive areas



**WARNING: Explosion hazard when used in potentially explosive areas**

When using the terminal in potentially explosive areas, observe the corresponding notes.



This data sheet is only valid in association with the IL SYS INST UM E user manual.



Make sure you always use the latest documentation.  
It can be downloaded from the product at [www.phoenixcontact.net/products](http://www.phoenixcontact.net/products).

---

<b>2</b>	<b>Table of contents</b>	
1	Description .....	1
2	Table of contents .....	2
3	Ordering data .....	3
4	Technical data .....	4
5	Additional tables .....	7
6	Internal circuit diagram .....	8
7	Local diagnostic indicators .....	9
8	Terminal point assignment.....	10
9	Electrical isolation.....	10
10	Installation instructions .....	10
11	Connection notes .....	11
12	Notes on using the terminal block in potentially explosive areas .....	12
13	Connection examples .....	13
14	Display devices .....	15
15	Configuration .....	17
16	Process data.....	17
17	OUT process data words .....	17
18	Process data input words IN .....	19
19	PCP communication .....	21
20	PCP object description .....	22
21	PCP mode error messages.....	28
22	Startup and measuring jumper detuning .....	28

### 3 Ordering data

Description	Type	Order No.	Pcs. / Pkt.
Inline analog strain gauge input terminal, complete with accessories (connector and labeling field), two precise inputs, 4, 6-conductor connection method	IB IL SGI 2/P-PAC	2884907	1
<b>Accessories</b>			
Inline shield connector (Plug/Adapter)	IB IL SCN-6 SHIELD	2726353	5
Connector, for digital 1, 2 or 8-channel Inline terminals (Plug/Adapter)	IB IL SCN-8	2726337	10
Labeling field, width: 12.2 mm (Marking)	IB IL FIELD 2	2727501	10
Insert strip, Sheet, white, Unlabeled, Can be labeled with: Office-Drucksysteme, Plotter: Laser printer, Mounting type: Insert, Lettering field: 62 x 10 mm (Marking)	ESL 62X10	0809492	1
Shield connection clamp, for shield on busbars, contact resistance < 1 mOhm (Assembly)	SK 8	3025163	10
Shield connection clamp, for shield on busbars, contact resistance < 1 mOhm (Assembly)	SK 14	3025176	10
Shield connection clamp, for shield on busbars, contact resistance < 1 mOhm (Assembly)	SK 20	3025189	10
Shield connection clamp, for shield on busbars, contact resistance < 1 mOhm (Assembly)	SK 35	3026463	10
Support for busbars (Assembly)	AB-SK	3025341	10
Support, Length: 95.5 mm, Width: 6.2 mm, Color: gray (Assembly)	AB-SK 65	3026489	10
Support, Length: 10 mm, Width: 56 mm, Height: 20 mm, Color: silver (Assembly)	AB-SK/E	3026476	10
PEN conductor busbar, 3mm x 10 mm, length: 1000 mm (Assembly)	NLS-CU 3/10 SN 1000MM	0402174	10
Power terminal block, Connection method Screw connection, Load current : 41 A, Cross section: 0.5 mm <sup>2</sup> - 6 mm <sup>2</sup> , Width: 7 mm, Color: silver	AK 4	0404017	50
Connection terminal block, Connection method Screw connection, Load current : 41 A, Cross section: 0.5 mm <sup>2</sup> - 6 mm <sup>2</sup> , Width: 7 mm, Color: green-yellow	AKG 4 GNYE	0421029	50
Connection terminal block, Connection method Screw connection, Load current : 41 A, Cross section: 0.5 mm <sup>2</sup> - 6 mm <sup>2</sup> , Width: 7 mm, Color: black	AKG 4 BK	0421032	50
Software CD for FDT container for integrating device DTMs (free download)	AX+ BASIC	2985068	1
DTM library	AX DTM LIB	2988065	1
<b>Documentation</b>			
User manual, English, Automation terminals of the Inline product range	IL SYS INST UM E	-	-
Application note, English, Inline terminals for use in zone 2 potentially explosive areas	AH EN IL EX ZONE 2	-	-
User manual, English, for the Peripherals Communication Protocol (PCP), only available as a download.	IBS SYS PCP G4 UM E	2745169	1
User manual, English, Porting using PCP compact	IBS PCP COMPACT UM E	-	-

## 4 Technical data

### Dimensions (nominal sizes in mm)

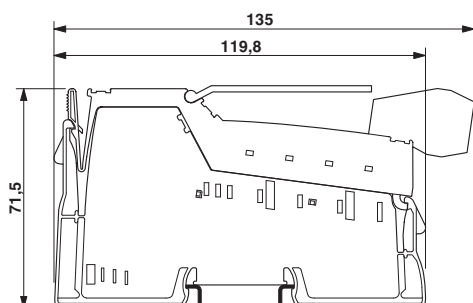

Width	48.8 mm
Height	136 mm
Depth	71.5 mm

### General data

Color	green
Weight	220 g
Operating mode	Process data operation with 3 words, PCP with 1 word
Ambient temperature (operation)	-25 °C ... 55 °C
Ambient temperature (storage/transport)	-25 °C ... 85 °C
Permissible humidity (operation)	10 % ... 95 % (according to DIN EN 61131-2)
Permissible humidity (storage/transport)	10 % ... 95 % (according to DIN EN 61131-2)
Air pressure (operation)	70 kPa ... 106 kPa (up to 3000 m above sea level)
Air pressure (storage/transport)	70 kPa ... 106 kPa (up to 3000 m above sea level)
Degree of protection	IP20
Protection class	III, IEC 61140, EN 61140, VDE 0140-1

### Connection data Inline connectors

Connection method	Spring-cage connection
Conductor cross section, solid	0.08 mm <sup>2</sup> ... 1.5 mm <sup>2</sup>
Conductor cross section, stranded	0.08 mm <sup>2</sup> ... 1.5 mm <sup>2</sup>
Conductor cross section [AWG]	28 ... 16

### Interface Inline local bus

Connection method	Inline data jumper
Transmission speed	500 kBit/s
Transmission physics	Copper

### Inline potential routing / Power consumption

Communications power $U_L$	7.5 V DC
Current consumption from $U_L$	max. 100 mA, typ. 85 mA

**Inline potential routing / Power consumption**

I/O supply voltage $U_{ANA}$	24 V DC
Current consumption from $U_{ANA}$	max. 100 mA 25 mA (in case of typical load of 350 Ohm per channel) 7 mA (for no-load operation without strain gauge or display) 80 mA (For a maximum load of 55 $\Omega$ and display)
Power consumption	Typ. 1.2 W (Device in nominal operation) max. 3.2 W (Device with maximum load)

**Voltage output**

Number of outputs	2
Impedance	> 55 $\Omega$ (per channel)
Output voltage	typ. 5 V
Output current	max. 90 mA (per channel)
Short-circuit protection of the voltage outputs	Yes, at least 1 minute through temperature monitoring

**Floating N/O contact**

Quantity	2 ( $K_{a1}$ - $K_{b1}$ , $K_{a2}$ - $K_{b2}$ )
Volume resistance	< 1 $\Omega$ (typical)
Volume resistance	5 $\Omega$ (maximum)
Typical response time	100 ms (typical)

**Serial interface**

Name	V.24 (RS-485) serial interface
Network	Yes
Addressing	Address 1 = Measured gross/net value Address 2 = Measured tare value
Termination resistor	120 $\Omega$
Transmission protocol	STX/ETX

**Input channels for strain gauge**

Number of inputs	2
Connection method	6 or 4-wire, twisted pair shielded cable
Characteristics	$\pm 1$ mV/V, $\pm 2$ mV/V, $\pm 3$ mV/V, $\pm 3.33$ mV/V, $\pm 4$ mV/V, $\pm 5$ mV/V
Bridge difference $U_d$	Measuring range specified by selecting the characteristic
Bridge voltage $U_0$	5 V
Measured value representation	15 bits + sign bit (process data); 15 bits + sign bit and measured display value in the ASCII character set (PCP)
Process data update	typ. 100 ms (12.5 ms, depends on the configuration)
Resolution A/D	24 bit
A/D conversion time	Typ. 100 ms (12.5 ms, depends on the configuration)
Averaging	Can be parameterized: None or using 4, 16 or 32 measured values; default setting: using 16 measured values
Limit frequency	0.3 Hz (with default setting)

**Programming Data**

ID code (hex)	DF
ID code (dec.)	223
Length code (hex)	03
Length code (dec.)	03
Process data channel	48 Bit
Input address area	6 Byte

**Programming Data**

Output address area	6 Byte
Parameter channel (PCP)	2 Byte
Register length (bus)	64 Bit

**PROFIBUS telegram data**

Required parameter data	23 Byte
Need for configuration data	5 Byte

**Error messages to the higher level control or computer system**

Failure of the power supply at $U_{ANA}$	Error message in the process data
Failure of or insufficient communications power $U_L$	I/O error message sent to the bus coupler
Peripheral fault	Error message in the process data

**Electrical isolation/isolation of the voltage areas**

Logic/analog I/O (digital isolator)	500 V AC, 50 Hz, 1 min
RS-485/analog I/O (isolating distance)	500 V AC, 50 Hz, 1 min
N/O contact $K_{a1} - K_{b1}$ / analog I/O (isolating distance)	500 V AC, 50 Hz, 1 min
N/O contact $K_{a2} - K_{b2}$ / analog I/O (isolating distance)	500 V AC, 50 Hz, 1 min
Functional earth ground/analog I/O (isolating distance)	500 V AC, 50 Hz, 1 min
Logic/RS-485 (digital isolator)	500 V AC, 50 Hz, 1 min
N/O contact $K_{a1} - K_{b1}$ / RS-485 (isolating distance)	500 V AC, 50 Hz, 1 min
N/O contact $K_{a2} - K_{b2}$ / RS-485 (isolating distance)	500 V AC, 50 Hz, 1 min
Functional earth ground/RS-485 (isolating distance)	500 V AC, 50 Hz, 1 min
Logic / N/O contact $K_{a1} - K_{b1}$ (optocoupler)	500 V AC, 50 Hz, 1 min
N/O contact $K_{a2} - K_{b2}$ /N/O contact $K_{a1} - K_{b1}$ (isolating distance)	500 V AC, 50 Hz, 1 min
Functional earth ground / N/O contact $K_{a1} - K_{b1}$ (isolating distance)	500 V AC, 50 Hz, 1 min
Logic / N/O contact $K_{a2} - K_{b2}$ (optocoupler)	500 V AC, 50 Hz, 1 min
Functional earth ground / N/O contact $K_{a2} - K_{b2}$ (isolating distance)	500 V AC, 50 Hz, 1 min
Logic/functional earth ground (isolating distance)	500 V AC, 50 Hz, 1 min

**Approvals**

For the latest approvals, please visit [www.phoenixcontact.net/products](http://www.phoenixcontact.net/products).

## 5 Additional tables

Tolerances at $T_A = 25^\circ\text{C}$		
Nominal characteristic value	Relative deviation in % related to the measuring range final value	
	Typical	Maximum
$\pm 1 \text{ mV/V}, \pm 2 \text{ mV/V}, \pm 3 \text{ mV/V}, \pm 3.33 \text{ mV/V}, \pm 4 \text{ mV/V}, \pm 5 \text{ mV/V}$	$\pm 0.01\%$	$\pm 0.05\%$

The typical values contain the typical offset error, gain error and linearity error in the respective configuration related to the positive measuring range up to 100% of the nominal characteristic value.

This data is valid for nominal operation (preferred mounting position,  $U_S = 24 \text{ V}$ ) with a conversion time of 100 ms and a 16-sample average value.

The maximum tolerance values represent the worst case measurement inaccuracy. Besides the maximum offset error, the gain error and the linearity error, the maximum tolerance values also comprise the longtime drift as well as the maximum tolerances of the test and calibration equipment.

Please also observe the values for temperature drift and the tolerances under influences of electromagnetic interferences.

Additional tolerances influenced by electromagnetic fields	
Type of electromagnetic interference	Typical deviation in % related to the measuring range final value
Electromagnetic fields; field strength 10 V/m according to EN 61000-4-3/ IEC 61000-4-3	$< \pm 0.1\%$
Conducted interference, Class 3 (10 V test voltage) according to EN 61000-4-6/IEC 61000-4-6	-
Fast transients (burst) up to an interference voltage of $\pm 2.2 \text{ kV}$ in acc. with EN 61000-4-4 / IEC 61000-4-4	-

The values refer to nominal operation with default settings.

Temperature and drift response ( $T_A = -25^\circ\text{C} \dots +55^\circ\text{C}$ )		
	Relative drift in ppm/K related to the measuring range final value	
	Typical	Maximum
$\pm 1 \text{ mV/V}, \pm 2 \text{ mV/V}, \pm 3 \text{ mV/V}, \pm 3.33 \text{ mV/V}, \pm 4 \text{ mV/V}, \pm 5 \text{ mV/V}$	5 ppm/K	15 ppm/K

The typical value contain the typical offset value and gain value in the respective configuration in the temperature range from  $-25^\circ\text{C}$  up to  $+55^\circ\text{C}$  related to the positive measuring range up to 100% of the nominal characteristic value.

This data is valid for nominal operation (preferred mounting position,  $U_S = 24 \text{ V}$ ) with a conversion time of 100 ms and a 16-sample average value.

The maximum tolerance values represent the worst case measurement inaccuracy. Besides maximum offset and gain drift, they also comprise longtime drift as well as the maximum tolerances of the test and calibration equipment.



## 6 Internal circuit diagram

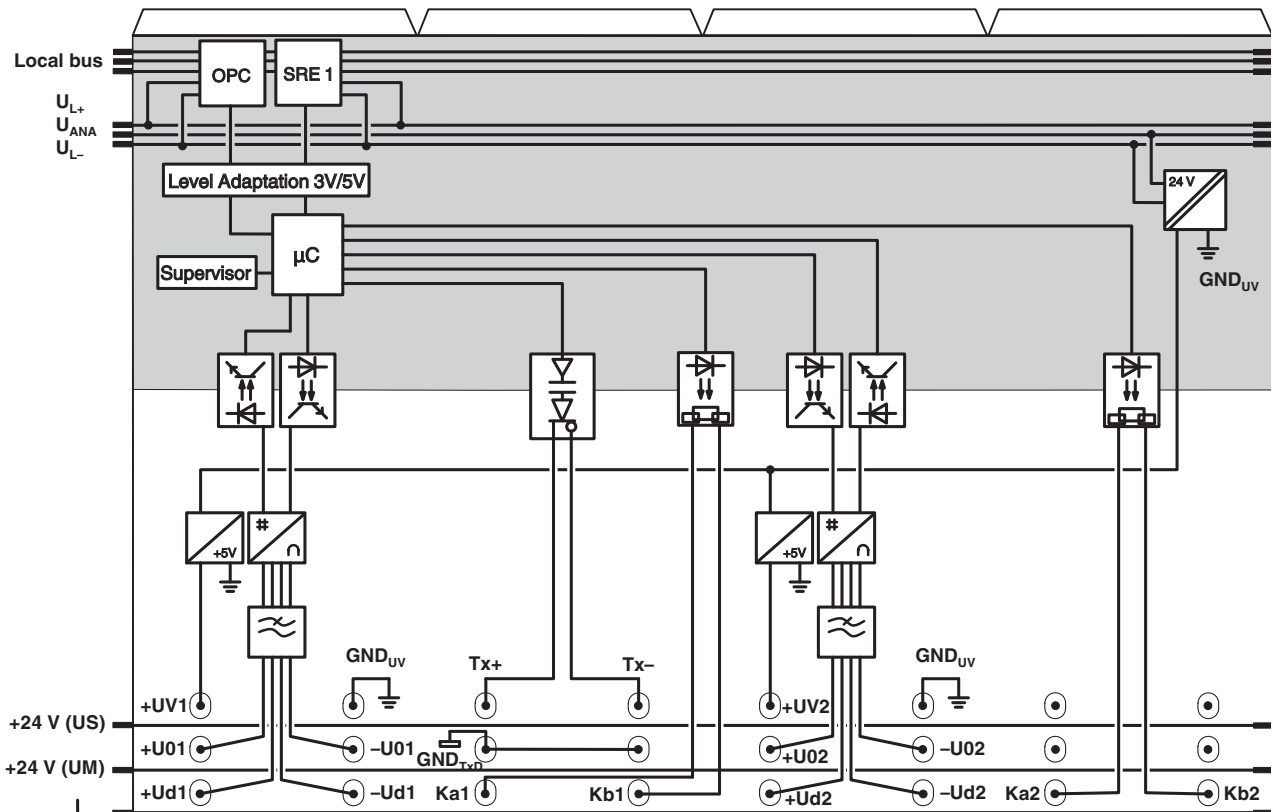















Figure 1 Internal wiring of the terminal points

Key:

	Protocol chip		Low pass filter
	Register expansion		DC/DC converter
	Level adaptation		DC/DC converter with electrical isolation
	Hardware monitoring		RS-485 interface with electrical isolation
	Microprocessor		Photomos relay
	Optocoupler with bipolar buffer		Electrically isolated area
	Analog/digital converter		Explanation for other used symbols has been provided in the IL SYS INST UM E user manual.

## 7 Local diagnostic indicators

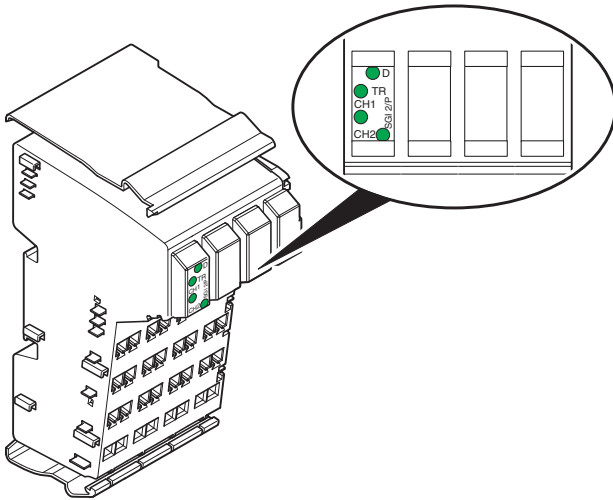

Figure 2 Local diagnostic indicators

Designation	Color	Meaning
D	green	Diagnostics (bus and logic voltage)
TR	green	PCP communication
CH 1	green	Diagnostics of channel 1
	Green ON	Channel 1 is OK
	green OFF	Channel 1 not connected or not supplied or open circuit
CH 2	green	Diagnostics of channel 2
	Green ON	Channel 2 is OK
	green OFF	Channel 2 not connected or not supplied or open circuit

An open circuit is detected according to the following table:

Faulty sensor cable	Open-circuit message in diagnostics
+U <sub>V</sub>	No
GND <sub>UV</sub>	Yes
+U <sub>0</sub>	Yes
-U <sub>0</sub>	Yes
+U <sub>d</sub>	Yes
-U <sub>d</sub>	Yes

### Note regarding open circuit message

During power up or configuration the system does not detect whether a sensor is connected or if a cable break has occurred (all cables disconnected) due to the measuring principle.

In this case, you will not obtain any valid data. As such, take the time to ensure that the sensor is fully connected.

If an open circuit message is output, first remove the cause prior to resetting the message.

If you do not remove the cause of the open circuit message and perform a voltage reset or configure the module, the module itself will behave according to the following table.

Open circuit message triggered by	Behavior following voltage reset or configuration
No sensor connected/cable break	Malfunction not detected and not reported
Defective sensor cable (GN-D <sub>UV</sub> , +U <sub>0</sub> , -U <sub>0</sub> , +U <sub>d</sub> , -U <sub>d</sub> )	Malfunction is detected and reported

### Function identification

Green

## 8 Terminal point assignment

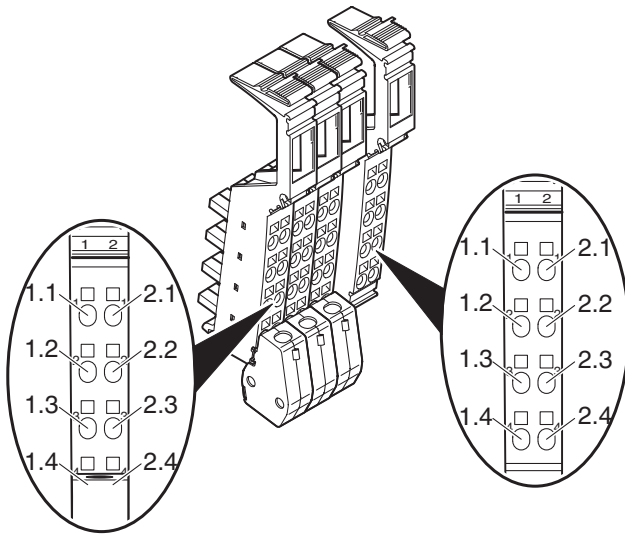

Figure 3 Terminal point assignment

Terminal point	Signal	Assignment
<b>Connector 1</b>		
1.1 / 2.1	+U <sub>V1</sub> /GND <sub>UV</sub>	Jumper supply U <sub>V1</sub>
1.2 / 2.2	+U <sub>01</sub> /-U <sub>01</sub>	Jumper voltage U <sub>01</sub>
1.3 / 2.3	+U <sub>d1</sub> /-U <sub>d1</sub>	Jumper difference U <sub>d1</sub>
1.4 / 2.4	FE	Shield connection
<b>Connector 2</b>		
1.1 / 2.1	Tx+ / Tx-	RS-485 interface
1.2 / 2.2	GND <sub>Tx</sub>	Reference potential of the RS-485 interface
1.3 / 2.3	K <sub>a1</sub> /K <sub>b1</sub>	N/O contact for shunt calibration of channel 1
1.4 / 2.4	FE	Shield connection
<b>Connector 3</b>		
1.1 / 2.1	+U <sub>V2</sub> /GND <sub>UV</sub>	Jumper supply U <sub>V2</sub>
1.2 / 2.2	+U <sub>02</sub> /-U <sub>02</sub>	Jumper voltage U <sub>02</sub>
1.3 / 2.3	+U <sub>d2</sub> /-U <sub>d2</sub>	Jumper difference U <sub>d2</sub>
1.4 / 2.4	FE	Shield connection
<b>Connector 4</b>		
1.1 / 2.1	-	Not used
1.2 / 2.2	-	Not used
1.3 / 2.3	K <sub>a2</sub> /K <sub>b2</sub>	N/O contact for shunt calibration of channel 2
1.4 / 2.4	FE	Shield connection



No definition is available for the designations of sensor cables. For this reason, the designations used in data sheets may deviate from those used by sensor manufacturers.

Examples:

Bridge voltage U<sub>0x</sub> = sense input U<sub>S</sub>

Bridge difference U<sub>dx</sub> = signal or output

## 9 Electrical isolation

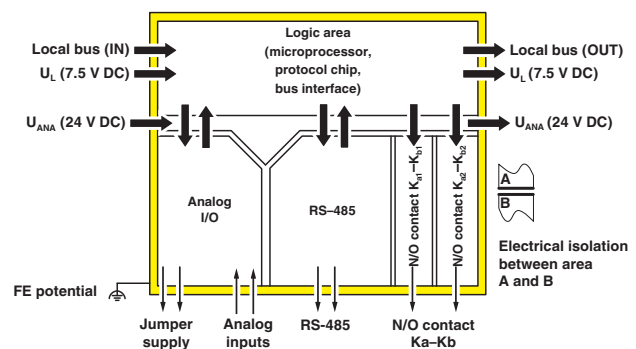

Figure 4 Electrical isolation of the individual function areas

## 10 Installation instructions

High current flowing through potential jumpers U<sub>M</sub> and U<sub>S</sub> leads to a temperature rise in the potential jumpers and inside the terminal. To keep the current flowing through the potential jumpers of the analog terminals as low as possible, always place the analog terminals after all the other terminals at the end of the main circuit (for the sequence of the Inline terminals: see also IL SYS INST UM E user manual).

## 11 Connection notes

### Connecting the strain gauges



Connect the strain gauges using shielded twisted pair cables.

### Connecting the shield



Only connect the shield at one point, preferably at the terminal. If the shield is securely connected to the sensor, insulate the shield on the terminal side.

### Unused channels



If a channel (connector 1 or connector 3) is not used, connect the following terminal points on this connector with each other: 1.1, 1.2 and 1.3 as well as 2.1, 2.2 and 2.3.

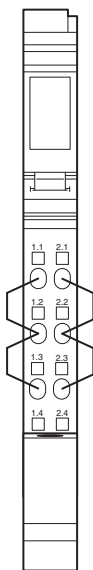

Figure 5 Jumpering the terminal points of unused channels

## 12 Notes on using the terminal block in potentially explosive areas



### **WARNING: Explosion hazard**

Please make sure that the following notes and instructions are observed.

### **Approval according to EC directive 94/9/EC**

Ⓢ II 3 G Ex nA IIC T4 Gc X

### **Installation notes**

1. This Inline terminal is a category 3 device and is suitable for installation in the potentially explosive areas of zone 2.  
The device meets the requirements of EN 60079-0:2009 and EN 60079-15:2010.
2. The Inline terminal must only be installed, operated, and maintained by qualified personnel.
3. Please follow the installation instructions given in the IL SYS INST UM E user manual and the package slip.
4. When installing and operating the device, the applicable safety directives (including national safety directives), accident prevention regulations, as well as general technical regulations, must be observed.
5. Please refer to the corresponding documentation (user manual, data sheet, package slip) and the certificates (declaration of conformity and other approvals, if applicable) for safety-related data.
6. Access to the circuits inside the Inline terminal is not permitted. Do not repair the Inline terminal by yourself but replace it with a terminal of the same type.  
Repairs may only be performed by the manufacturer. The manufacturer is not liable for damage resulting from non-compliance.
7. The IP20 degree of protection (EN 60529) of the device is intended for a clean and dry environment.
8. Do not subject the Inline terminal to mechanical strain and/or thermal loads, which exceed the limits specified in the product documentation.
9. The Inline terminal has not been designed for use in potentially dust-explosive atmospheres.

### **Installation in zone 2**

1. Observe the specified conditions for use in potentially explosive areas.
2. Install the device in a suitable approved housing (with at least IP54 degree of protection) that meets the requirements of EN 60079-15. Observe the requirements of EN 60079-14.
3. In potentially explosive areas, the Inline terminal may only be snapped on or off and cables may only be connected when the power is switched off.
4. In zone 2, only connect devices to the supply and signal circuits that are suitable for operation in potentially explosive areas of zone 2 and the conditions at the installation location.

### **Restrictions/limit values**

1. **Only Inline terminals that are approved for use in potentially explosive areas may be assembled on this Inline terminal.**  
Before using an Inline terminal in a zone 2 potentially explosive area, check whether it has been approved for installation within this area.  
For a list of terminals that are approved for the potentially explosive areas of zone 2, please refer to the AH EN IL EX ZONE 2 application note.
2. The maximum permissible current for each tension spring contact is 2 A.

### 13 Connection examples

#### 13.1 6-wire connection (a strain gauge load cell per channel) with two indicators

The RS-485 interface has bus capability and can operate several devices. When an address is selected, the current measured value of channel 1 or channel 2 can be displayed.

Use a twisted-pair, shared and shielded data line to connect the displays. Fit a termination resistor to the data cable at the most remote point of the RS-485 network. Use the integrated termination resistors of the display for this purpose.

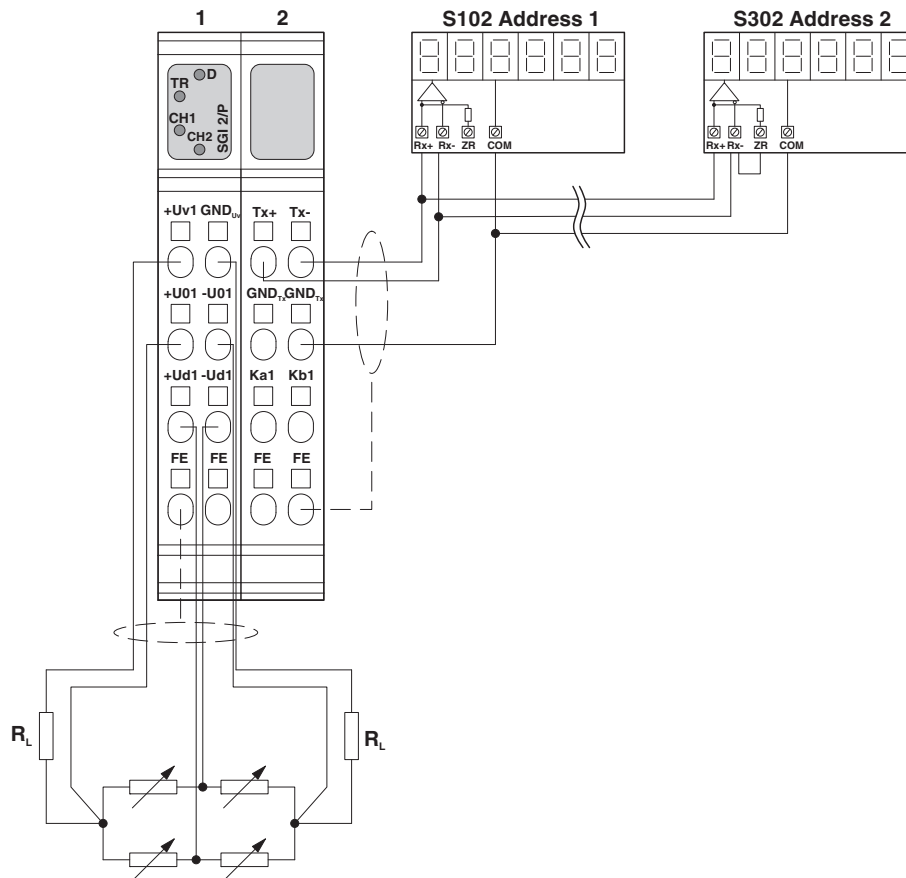

Figure 6 Connection of strain gauges in 6-wire technology

Key:

- $R_L$ : Cable resistance
- Address 1: Displays the measured value of channel 1
- Address 2: Displays the measured value of channel 2



The RS-485 interface transmits a special weighing protocol.

### 13.2 6-wire connection (several strain gauge load cells per channel)

Each channel can supply a current of up to 90 mA. For instance, 6 load cells with a basic resistance of 350 Ω may be connected in parallel.

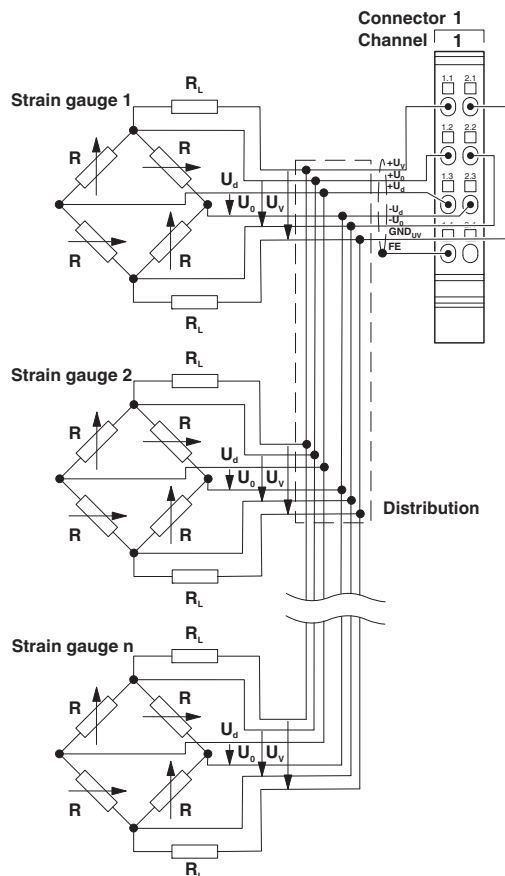

Figure 7 Connection of several strain gauges in 6-wire technology

Key:  
 $R_L$ : Cable resistance

### 13.3 4-wire connection with a shunt resistor

The following figure shows the connection of a resistive pressure sensor with an 80% calibration. This sensor is typically used for injection molding of plastics.

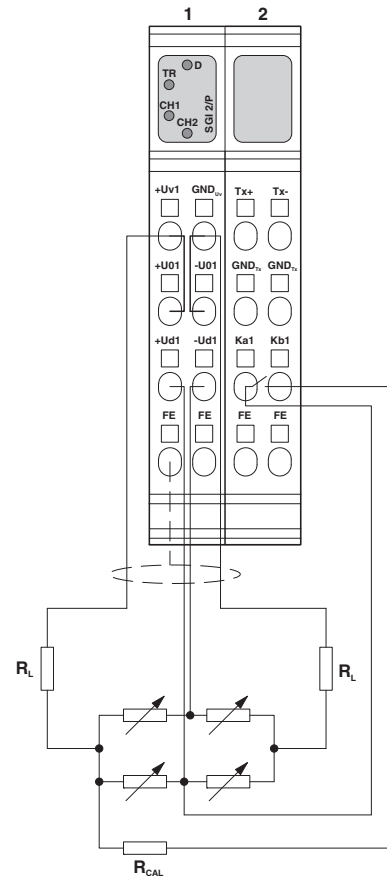

Figure 8 Connection of strain gauges in 4-wire technology with a shunt resistor

Key:  
 $R_L$ : Cable resistance

**Channel 1/channel 2:** Strain gauges can also be connected to the terminal in 4-wire technology. In this case connect  $+U_V$  with  $+U_0$  and  $GND_{UV}$  with  $-U_0$ . There is no temperature and long-term drift compensation for the connecting cable in 4-wire technology.

## 14 Display devices

A digital display from Siebert Industrieelektronik GmbH may be connected to the RS-485 interface of the terminal (see following table).

Siebert Industrieelektronik GmbH

Siebertstrasse, 66571 Eppelborn, Germany

Postfach 1180, 66571 Eppelborn, Germany

Phone: +49 (0) 6806/980-0

Fax: +49 (0) 6806/980-999

Internet: www.siebert.de

E-mail: info@siebert.de

Ordering types are, for example:

- Character height: 14 mm, 57 mm, 100 mm, 160 mm, or 250 mm
- Character color: Red, white, green
- Display: Single or double-sided
- Dimension symbols (fixed on strips, specify when ordering):  
F101 for g, F102 for kg, F103 for t
- Degree of protection: IP40, IP54, IP65
- Assembly: Panel, wall and suspended mounting
- Operating voltage: 24 V DC, 230 V DC
- ...



Please contact Siebert Industrieelektronik GmbH for further information or ordering types.

Feature	Digital display S102 for panel mounting	Large size display S302 for indoor installation	Large size display S302 for outdoor installation
Order designation	S102-W6/14/0R-000/0B-SL with dimension symbol F102	S302-F6/10/0R-100/0A-SL with dimension symbol F102	S302-F6/10/0R-114/0A-SL with dimension symbol F102 and weather protection hood -1011
Dimensions (W x H x D)	96 mm x 48 mm x 70 mm	870 mm x 245 mm x 145 mm	870 mm x 245 mm x 145 mm
Character height	14 mm	100 mm	100 mm
Reading distance		Up to 40 m	Up to 40 m
Character color	Bright red LED display	Bright red LED display for indoors	Red "super bright" LED display for outdoors
Display	6 digits	6 digits, single-sided	6 digits, single-sided
Dimension symbol	kg (F102)	kg (F102)	kg (F102)
Interface	Serial (RS-485)	Serial (RS-485)	Serial (RS-485)
Degree of protection	IP40	IP54	IP54 with climate compensation, heating and weather protection hood
Assembly	Panel mounting	Wall mounting, cable entry at bottom	Wall mounting, cable entry at bottom
Operating voltage	24 V DC	230 V AC	230 V AC
Other			Steel sheet housing, double-layer painting



Display dimensions

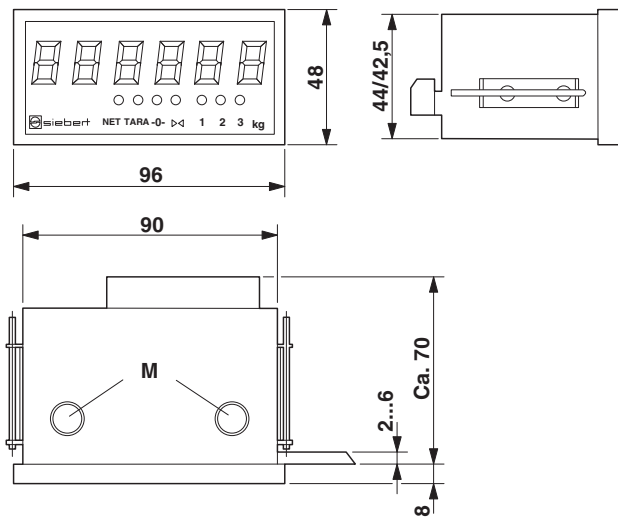

Figure 9 Dimensions of display S102 ... (dimensions in mm)

M: Menu button

Panel cutout 92 mm x 45 mm

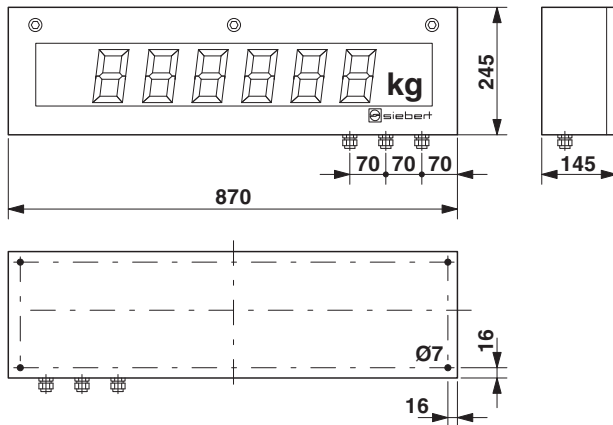

Figure 10 Dimensions of display S302 ... (dimensions in mm)

Connector pin assignment of the displays



For the connector pin assignment of the displays, please refer to the documentation of the displays.

Measured value representation on the display

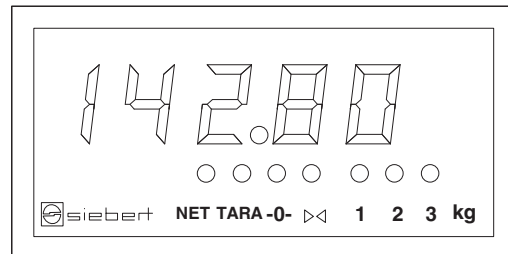

Figure 11 Example of a display

LEDs on the display

Designation	Meaning
NET	Net, LED lights up after a tare weight adjustment
TARA	Not supported
-0-	Zero point reached
><	Standstill reached
1	Channel 1
2	Channel 2
3	Not supported

The display is updated every 500 ms.

## 15 Configuration

Terminal configuration is only required if at least one of the channels is to be operated outside the default values.

You can configure the terminal either using process data or using PCP and transmit the analog values accordingly.



For easy terminal configuration a function block can be downloaded at [www.phoenixcontact.net/products](http://www.phoenixcontact.net/products)

The configuration options differ for configuration using process data (PD) and configuration using PCP.

The following configurations are possible:

Configuration	Short designation	Default	PD	PCP
Selection of mean-value generation	Mean-value	16-sample mean-value	X	X
Conversion time of the A/D converter	Conversion time	100 ms	X	X
Nominal characteristic value of the connected sensor	Nominal characteristic value	$\pm 2$ mV/V	X	X
Nominal load of the connected sensor	Nominal load	0	-	X
Adjustment value of the connected sensor	Adjustment value	0	-	X

## 16 Process data

The terminal occupies three process data words and one PCP word.

Order of the process data words:

OUT0 (control word)	OUT1	OUT2
------------------------	------	------

IN0 (status word)	IN1	IN2
----------------------	-----	-----

## 17 OUT process data words

Three OUT process data words are available.

The terminal is configured using the OUT process data words.

Where:

- Output word OUT0 contains the command
- Output word OUT1 contains the parameters for channel 1
- Output word OUT2 contains the parameters for channel 2

Configuration errors are indicated in the status word. The configuration settings are stored in a volatile memory.

If you change the configuration, the message "Measured value invalid" appears (diagnostic code 8004<sub>hex</sub>), until new measured values are available.

**17.1 Output word OUT0 (control word)**

		OUT0							
Bit	15 ... 8	7	6	5	4	3	2	1	0
Assignment	Command code	0	0	0	0	0	0	0	0

Bit 15 to bit 8 (command code):

Bit 15 ... 8	OUT0 [hex]	Command function
00000000	0000	Reading measured values
0001000C	1x00	Read configuration in IN1 channel-by-channel. C = Channel number; 0 = Channel 1, 1 = Channel 2)
00110000	3000	Read minimum value; IN1: Minimum value channel 1 IN2: Minimum value channel 2
00110001	3100	Read maximum value; IN1: Maximum value channel 1, IN2: Maximum value channel 2
00110010	3200	Delete minimum and maximum value of channel 1
00110011	3300	Delete minimum and maximum value of channel 2
00111100	3C00	Read firmware version and module ID in IN1.
01000000	4000	Configure device; configuration for channel 1 in OUT1 and for channel 2 in OUT2



During the transient response (e.g., following a configuration command), the fluctuating measured values may exceed the minimum and maximum values. Therefore, at the start of acquisition delete the minimum and maximum values using command 3200<sub>hex</sub> and/or 3300<sub>hex</sub>. The minimum value is set to the largest positive number (7FF<sub>hex</sub> = 32767<sub>dec</sub>) when deleting. The maximum value is set to the largest negative number (8000<sub>hex</sub> = -32768<sub>dec</sub>).

**17.2 Output words OUT1 and OUT2 (parameter words)**

For command 4000<sub>hex</sub> the parameters must be specified in OUT1 and OUT2. This parameter word is only evaluated for this command.

		OUT1 and OUT2														
Bit	15	14	13	12	11	10	9	8	7	6	5	4	3	2	1	0
Assignment	0	0	0	0	0	0	M	0	0	0	W				N	

Where:

M	Mean-value	Selects mean-value generation. After every conversion, the measured value is saved in a mean-value memory via which the mean-value is generated. The memory size can be selected with the mean-value option. E.g., for a 16-sample mean-value, the mean-value is generated using the last 16 measured values.
W	Conversion time	Conversion time of the analog/digital converter
N	Nominal characteristic value	Selects the measuring range



Set all unused bits to 0.



If invalid parameters are specified in the parameter word, the command will not be executed. The command is acknowledged in the input words with the set error bit.

**Parameters for configuration**

The values displayed in bold are pre-settings.

Bits 10 to 9:

Code		M: Mean-value
dec	bin	
<b>0</b>	<b>00</b>	<b>16-sample mean-value</b>
1	01	No mean-value
2	10	4-sample mean-value
3	11	32-sample mean-value

Bit 4:

Code		C: Conversion time of the analog-digital converter
dec	bin	
<b>0</b>	<b>0</b>	<b>100 ms</b>
1	1	12.5 ms

Bit 3 to bit 0:

Code		N: Nominal specific value
dec	bin	
0	0000	±1 mV/V
<b>1</b>	<b>0001</b>	<b>±2 mV/V</b>
2	0010	±3 mV/V
3	0011	±3.33 mV/V
4	0100	±4 mV/V
5	0101	±5 mV/V
Other		Invalid

**Step response and limit frequencies**

The following table specifies the time for the step response and the limit frequency depending on the settings for conversion time and mean-value.

Conversion time	Mean-value	Step response from 0% to 100% (typical)	Limit frequency (typical)
100 ms	32-sample	3.4 s	0.15 Hz
<b>100 ms</b>	<b>16-sample</b>	<b>1.8 s</b>	<b>0.3 Hz</b>
100 ms	4-sample	600 ms	1 Hz
100 ms	None	200 ms	2.5 Hz
12.5 ms	32-sample	425 ms	1 Hz
12.5 ms	16-sample	225 ms	2.5 Hz
12.5 ms	4-sample	75 ms	10 Hz
12.5 ms	None	25 ms	20 Hz

**18 Process data input words IN**

**18.1 Input word IN0 (status word)**

Input word IN0 performs the task of a status word.

		IN0									
Bit		15	14 ... 8	7	6	5	4	3	2	1	0
Assignment		EB	SP		0	0	0	0	0	0	0

**EB: Error Bit**

- EB = 0 No error has occurred.
- EB = 1 An error has occurred.

The error bit indicates whether a command could be executed without errors or not.

For the command code 4000hex (configure device), a set error bit indicates an invalid configuration. Possible reasons:

- At least one of reserved bits is set.
- An invalid value was specified for the nominal characteristic value.

For the command code 0000<sub>hex</sub> (read measured values), the error bit indicates a group error message. When the error bit is set, there is an error message on one or both channels.

**Mirrored command code:**

A command code mirrored from the control word. Here, the MSB is suppressed.

### 18.2 Input words IN1 and IN2

The measured values, configuration or firmware version are transmitted to the controller board or the PC via process data input words IN1 and IN2 according to the configuration.

For control word 3C00<sub>hex</sub>, IN1 provides the firmware version and the module ID.

The module ID for the terminal is 3<sub>hex</sub>.

#### Example: Firmware version 1.23

		IN1															
Bit		15	14	13	12	11	10	9	8	7	6	5	4	3	2	1	0
Assignment (hex)		1					2					3			3		
Meaning		Firmware version 1.23													Module ID		

#### Measured values

The measured values are available in IB IL format.

The measured value is represented in bits 14 to 0. An additional bit (bit 15) is available as a sign bit.

15	14	13	12	11	10	9	8	7	6	5	4	3	2	1	0
SB	Analog value														

- Bit 15: Most significant bit (MSB)
- Bit 0: Least significant bit (LSB)
- SB Sign bit

The IB IL format supports extended diagnostics. Values >8000<sub>hex</sub> and <8100<sub>hex</sub> indicate an error.

The following diagnostic codes are possible:

Code (hex)	Error
8001	Measuring range exceeded (overrange)
8002	Open circuit
8004	Measured value invalid/no valid measured value available
8020	Faulty supply voltage
8040	Device faulty
8080	Below measuring range (underrange)

An open circuit is detected according to the following table:

Faulty sensor cable	Open-circuit message in diagnostics
+U <sub>V</sub>	No
GND <sub>UV</sub>	Yes
+U <sub>0</sub>	Yes
-U <sub>0</sub>	Yes
+U <sub>d</sub>	Yes
-U <sub>d</sub>	Yes



Please observe the notes regarding open circuit message under "Local diagnostic indicators"

Typical measured values:

Detuning in % of nominal value [%]	Input word [hex]	Input word [dec]
> 130.048	8001	Overrange
+130.048	7F00	32512
+100.000	61A8	25000
+1.000	00FA	250
+0.004	0001	1
0.0	0000	0
-0.004	FFFF	-1
-100.000	9E58	-25000
-130.048	8100	-32512
< -130.048	8080	Underrange
-	8002	Open circuit

To calculate the detuning as a percentage for other measured values, please use the following formula:

$$\text{Detuning} = \text{Process data value} * 0.004 \text{ or}$$

$$\text{Detuning} = \text{Process data value}/250$$

#### Example:

Nominal characteristic value ±2 mV/V  
 Process data value 10000<sub>dec</sub>

$$\text{Detuning} = 10000/250 = 40\%$$

$$40\% \text{ of } 2 \text{ mV/V} = 0.8 \text{ mV/V}$$

## 19 PCP communication

### 19.1 General information



For information on PCP communication, please refer to the PCP user manuals (see Ordering data).



The programs IBS CMD (for standard controller boards) and PC WorX (for Controllers (ILC), Field Controllers (FC) and Remote Field Controllers (RFC)) are available for the configuration and parameterization of your INTERBUS system.

For additional information, please refer to the documentation of the software used.

By default upon delivery, the terminal is configured according to the default settings (under configuration). The terminal can be configured using process data or PCP to suit your application.

In PCP mode, the terminal is configured with the "Config Table" object.

### 19.2 Object dictionary for PCP communication

Index	Data type	A	L	Meaning	Object name	Rights
0080 <sub>hex</sub>	Record	2	8	Terminal configuration	Config Table	rd/wr
0081 <sub>hex</sub>	Unsigned 16	2	2	Analog values of the channels	Analog Values	rd
0082 <sub>hex</sub>	Record	2	6	Measured values in the extended float format	Measured Value Float	rd
0083 <sub>hex</sub>	Record	2	6	Display value in the extended float format	Display Value Float	rd
0091 <sub>hex</sub>	Unsigned 8	2	1	Dynamic control of tare weight adjustment	Control Dynamic	wr
0092 <sub>hex</sub>	Unsigned 8	2	1	Static control of path adjustment	Control Static	wr
0093 <sub>hex</sub>	Unsigned 8	2	1	Status of the Inline terminal	Status	rd
0097 <sub>hex</sub>	Var of Visible String	1		Display string of channel 1	Display String Channel 1	rd
0098 <sub>hex</sub>	Var of Visible String	1		Display string of channel 2	Display String Channel 2	rd
009A <sub>hex</sub>	Unsigned 8	2	1	Reset to default settings	Default Setting	wr
0018 <sub>hex</sub>	Record	6		Diagnostics	Diag State	rd

A        Number of elements                          rd        Read access permitted  
L        Length of an element in bytes                  wr        Write access permitted

## 20 PCP object description

### 20.1 "Config Table" object

Configure the terminal using this object.

#### Object description:

Object	Config Table	
Access	Read, write	
Data type	Array of Records Record = 4 x Unsigned 16	2 x 8 bytes
Index	0080 <sub>hex</sub>	
Subindex	00 <sub>hex</sub>	Write all elements
	01 <sub>hex</sub>	Configuration of channel 1 Nominal load (MAX) of channel 1 Adjustment value of channel 1 Reserved
	02 <sub>hex</sub>	Configuration of channel 2 Nominal load (MAX) of channel 2 Adjustment value of channel 2 Reserved
Length (bytes)	10 <sub>hex</sub>	Subindex 00 <sub>hex</sub>
	08 <sub>hex</sub>	Subindex 01 <sub>hex</sub> to 02 <sub>hex</sub>
Data	Terminal configuration	

#### Element value range

The "Configuration channel x" elements have the following structure:

		OUT1 and OUT2															
Bit		15	14	13	12	11	10	9	8	7	6	5	4	3	2	1	0
Assignment		0	0	0	0	0	M	0	0	0	0	W				N	

Where:

- M Mean-value
- W Conversion time
- N Nominal characteristic value

Value range: See "Parameters for configuration"  
 Default value: See "Parameters for configuration"

#### Nominal load (MAX) element:

Value range: 0 ... 65535<sub>dec</sub>  
 Default value: 0

#### Adjustment value element:

Value range: 0 ... 32767<sub>dec</sub>  
 Default value: 0

#### Please note for the "Nominal load (MAX)" element:

If MAX = 0, no value is output on the display of the channel. MAX dimensions the maximum value of the display and the display format.

Nominal load (MAX)	Display format
1 ... 9	1.2345
10 ... 99	12.345
100 ... 999	123.45
1000 ... 9999	1234.5
10000 ... 65535	12345

MAX corresponds to a detuning of 100%. The use of MAX provides for the maximum value of a sensor to be input.  
 Example: Sensor with 1 mV/V and MAX = 50 kg. Configuration of the terminal with MAX = 50<sub>dec</sub>. Then the display corresponds directly to the measured weight in kg.

Jumper difference	Process data value	Display
0.5 mV/V	12500 <sub>dec</sub> -> 50%	25.000
1.0 mV/V	25000 <sub>dec</sub> -> 100%	50.000

If an invalid configuration is specified, a negative confirmation is generated with error message 08<sub>hex</sub>, 00<sub>hex</sub> or xx30<sub>hex</sub>. The low byte of the Additional\_Error\_Code is 30<sub>hex</sub> (value is out of range), the high byte contains the number of the affected element.

Example: Config Table is completely written with data (subindex 00) and the entry for channel 2 is invalid. In this case, the Additional\_Error\_Code is equal to 0230<sub>hex</sub>.

#### Please note for the "Adjustment value" element:

The value is specified as a percentage of MAX. An LSB corresponds to 0.004%.

Example:

Sensor with 50 kg nominal load (MAX).  
 It should be adjusted to 25 kg.  
 Then the adjustment value corresponds to 50% of MAX.  
 Determine the adjustment value as follows:  
 50% / 0.004% = 12500.  
 Therefore configure the adjustment value with 12500<sub>dec</sub>.

### 20.2 "Analog Values" object

The elements of this object contain the analog values of the channels in IB IL format.

#### Object description:

Object	Analog Values	
Access	Read	
Data type	Array of Unsigned 16	2 x 2 bytes
Index	0081 <sub>hex</sub>	
Subindex	00 <sub>hex</sub>	Read all elements
	01 <sub>hex</sub>	Analog value of channel 1
	02 <sub>hex</sub>	Analog value of channel 2
Length (bytes)	04 <sub>hex</sub>	Subindex 00 <sub>hex</sub>
	02 <sub>hex</sub>	Subindex 01 <sub>hex</sub> to 02 <sub>hex</sub>
Data	Analog values of the channels	

### 20.3 Extended Float Format for objects 0082<sub>hex</sub> and 0083<sub>hex</sub>

The Extended Float Format is a specially defined format. It consists of the measured value in the float format, a status and a unit code. The construct is defined as a Record.

Status is necessary because the float format defines no patterns providing information on the status of the numerical value.

Status corresponds to the LSB of the Inline diagnostic codes (e.g. overrange: Status = 01, Inline diagnostic code = 8001<sub>hex</sub>). If Status = 0, the measured value is valid.

Record structure:

Element	Data type	Length in bytes	Meaning
1	Float	4	Value in the float format acc. to IEEE 754
2	Unsigned 8	1	Status
3	Unsigned 8	1	Unit code

"Units Code" combines the ASCII characters of the "Config Table" in an 8-bit code.

Code	Unit
57 (39 <sub>hex</sub> )	Percentage (%)
61 (3D <sub>hex</sub> )	Kilograms (kg)

Structure of the float format according to IEEE 754 in the bit representation:

VEEE EEEE	EMMM MMMM	MMMM MMMM	MMMM MMMM
-----------	-----------	-----------	-----------

- SB        1 sign bit, 0: positive, 1: negative
- E        8 bits exponent with offset 7F<sub>hex</sub>
- M        23 bits mantissa

Some example values for conversion from floating point to hexadecimal representation:

Floating point	Hexadecimal representation
1.0	3F 80 00 00
10.0	41 20 00 00
1.03965528	3F 85 13 6D
- 1.0	BF 80 00 00



### 20.4 "Measured Value Float" object

The elements of this object contain the measured values in the highest accuracy of the terminal.

#### Object description:

Object	Measured Value Float	
Access	Read	
Data type	Array of Records	2 x 6 bytes
Index	0082 <sub>hex</sub>	
Subindex	00 <sub>hex</sub>	Read all elements
	01 <sub>hex</sub>	Measured value of channel 1 (Record)
	02 <sub>hex</sub>	Measured value of channel 2 (Record)
Length (bytes)	0C <sub>hex</sub>	Subindex 00 <sub>hex</sub>
	06 <sub>hex</sub>	Subindex 01 <sub>hex</sub> to 02 <sub>hex</sub>
Data	Measured values in the extended float format	

### 20.5 "Display Value Float" object

The elements of this object contain the display values of the channels in the highest accuracy of the terminal.

#### Object description:

Object	Display Value Float	
Access	Read	
Data type	Array of Records	2 x 6 bytes
Index	0083 <sub>hex</sub>	
Subindex	00 <sub>hex</sub>	Read all elements
	01 <sub>hex</sub>	Display value of channel 1 (Record)
	02 <sub>hex</sub>	Display value of channel 2 (Record)
Length (bytes)	0C <sub>hex</sub>	Subindex 00 <sub>hex</sub>
	06 <sub>hex</sub>	Subindex 01 <sub>hex</sub> to 02 <sub>hex</sub>
Data	Display values of the channels in the extended float format	

### 20.6 "Control Dynamic" object

The elements of this object are used for the tare weight adjustment.

#### Object description:

Object	Control Dynamic	
Access	Write	
Data type	Array of Unsigned 8	2 x 1 byte
Index	0091 <sub>hex</sub>	
Subindex	00 <sub>hex</sub>	Write all elements
	01 <sub>hex</sub>	Channel 1
	02 <sub>hex</sub>	Channel 2
Length (bytes)	02 <sub>hex</sub>	Subindex 00 <sub>hex</sub>
	01 <sub>hex</sub>	Subindex 01 <sub>hex</sub> to 02 <sub>hex</sub>
Data	Control of tare weight adjustment; See below for the bit assignment	

"Control Dynamic" for each channel

Bit	7	6	5	4	3	2	1	0
Assignment	0	0	0	0	0	0	0	Tare

Value range:

Tare	0	No action
	1	Make a tare weight adjustment

The tare value is not stored in the EEPROM. After power up, the value = 0.

### 20.7 "Control Static" object

The elements of this object are used for the path adjustment.

#### Object description:

Object	Control Static	
Access	Write	
Data type	Array of Unsigned 8	2 x 1 byte
Index	0092 <sub>hex</sub>	
Subindex	00 <sub>hex</sub>	Write all elements
	01 <sub>hex</sub>	Channel 1
	02 <sub>hex</sub>	Channel 2
Length (bytes)	02 <sub>hex</sub>	Subindex 00 <sub>hex</sub>
	01 <sub>hex</sub>	Subindex 01 <sub>hex</sub> to 02 <sub>hex</sub>
Data	Static control of path adjustment	

"Control Static" for each channel

Bit	7	6	5	4	3	2	1	0
Assignment	0	0	0	0	K <sub>a</sub> -K <sub>b</sub>	J	N	0

Where:

K <sub>a</sub> -K <sub>b</sub>	N/O contact K <sub>a</sub> -K <sub>b</sub>
J	Adjustment
N	Zero point

Value range:

K <sub>a</sub> -K <sub>b</sub>	0	Open N/O contact K <sub>a</sub> -K <sub>b</sub>
	1	Close N/O contact K <sub>a</sub> -K <sub>b</sub>
Adjustment	0	No action
	1	Adjusting
Zero point	0	No action
	1	Determine zero point



Do not carry out the actions "Adjustment" and "Determine zero point" at the same time.

The "Adjustment" and "Determine zero point" actions are used for the path adjustment. The values are stored in a non-volatile way in the EEPROM.

When there is an adjustment to be done and an adjustment value has not yet been determined with "Config Table", a negative Write Confirmation with the error message 08, 00, 0021<sub>hex</sub> is generated. This message means that the service cannot be executed at present.

### 20.8 "Status" object

The elements of this object contain the status of the status LEDs of the display as well as information about the default of the adjustment values.

#### Object description:

Object	Status	
Access	Read	
Data type	Array of Unsigned 8	2 x 1 byte
Index	0093 <sub>hex</sub>	
Subindex	00 <sub>hex</sub>	Read all elements
	01 <sub>hex</sub>	Channel 1
	02 <sub>hex</sub>	Channel 2
Length (bytes)	02 <sub>hex</sub>	Subindex 00 <sub>hex</sub>
	01 <sub>hex</sub>	Subindex 01 <sub>hex</sub> to 02 <sub>hex</sub>
Data	Status of the display LEDs and information about the default setting; see below for the bit assignment	

"Status" of each channel

Bit	7	6	5	4	3	2	1	0
Assignment	0	0	0	Def	0	NET	-0-	><

Value range:

Def (Default)	0	The adjustment values of the path adjustment correspond to the default setting.
	1	The adjustment values of the path adjustment do not correspond to the default setting.
NET, -0-, ><	0	LED OFF
	1	LED ON



The bits NET, -0- and >< are only maintained when the display is active, i.e. the nominal load is unequal 0.