



Chipsmall Limited consists of a professional team with an average of over 10 year of expertise in the distribution of electronic components. Based in Hongkong, we have already established firm and mutual-benefit business relationships with customers from,Europe,America and south Asia,supplying obsolete and hard-to-find components to meet their specific needs.

With the principle of “Quality Parts,Customers Priority,Honest Operation,and Considerate Service”,our business mainly focus on the distribution of electronic components. Line cards we deal with include Microchip,ALPS,ROHM,Xilinx,Pulse,ON,Everlight and Freescale. Main products comprise IC,Modules,Potentiometer,IC Socket,Relay,Connector.Our parts cover such applications as commercial,industrial, and automotives areas.

We are looking forward to setting up business relationship with you and hope to provide you with the best service and solution. Let us make a better world for our industry!



## Contact us

Tel: +86-755-8981 8866 Fax: +86-755-8427 6832

Email & Skype: info@chipsmall.com Web: www.chipsmall.com

Address: A1208, Overseas Decoration Building, #122 Zhenhua RD., Futian, Shenzhen, China



# FL BT SPA

**Serial Bluetooth adapter for a wireless connection of a serial interface to a Bluetooth access point**



## AUTOMATION

Data Sheet  
7660\_en\_01

© PHOENIX CONTACT - 04/2008

### 1 Description

The FL BLUETOOTH Serial Port Adapter (FL BT SPA) is serial Bluetooth device that meets industrial needs. The BT SPA supports Bluetooth specification 2.0. It features a D-SUB 9 port and a Bluetooth interface.

#### Features of the wireless interface

- Bluetooth 2.0, HID profile
- Frequency range 2.4000 GHz to 2.4835 GHz
- ISM band
- The maximum emitted transmission power can be set between 0 dBm/1 mW and 16 dBm/39.8 mW, automatically controlled
- Diagnostic and status indicators

#### Device properties

- RS-232 interface (V.24), RS-422, RS-485
- Secure data transmission thanks to 128-bit encryption
- Support of SPP Bluetooth profile
- Configurable range of 0.1 m to 250 m outdoors

- Automatic transmission power control (AFH)
- Configuration using Bluetooth and the web-based management of the FL BT SPA or AT commands
- Bluetooth qualified as product (Bluetooth version 2.0)
- Wireless LAN co-existence support through channel skipping and low emission mode
- Replaceable antenna

#### Features and fields of application of the FL BT SPA

- Reliable transmission of serial data in harsh industrial environments
- Parallel operation of multiple wireless cells
- Cyclic transmission of serial data
- Operation of up to seven FL BT SPAs at a single access point.
- Point-to-point connection of two FL BT SPAs



**NOTE:** Operation of the wireless system is permitted only when using accessories available from Phoenix Contact. The use of other accessory components invalidates the approval of operation.



Make sure you always use the latest documentation.

It can be downloaded at [www.download.phoenixcontact.com](http://www.download.phoenixcontact.com).

A conversion table is available on the Internet at [www.download.phoenixcontact.com/general/7000\\_en\\_00.pdf](http://www.download.phoenixcontact.com/general/7000_en_00.pdf).



This data sheet is valid for the products listed on the following page:

## 2 Ordering data

### Products

Description	Type	Order No.	Pcs./Pkt.
Serial Bluetooth adapter	FL BT SPA	2884952	1
Factory Line Wireless Bluetooth access point	FL BLUETOOTH AP	2737999	1
<b>DIN rail adapter</b> for mounting the Bluetooth devices on a standard DIN rail	FL BT ADAPTER	2884949	1

### Accessories

Description	Order Designation	Order No.	Pcs./Pkt.	
<b>Antenna with omni-directional characteristics</b> Antenna connection Gain Degree of protection Impedance Horizontal transmission angle Vertical transmission angle	SMA connector 5 dBi IP55 50 Ω 360° 45°	RAD-ISM-2400-ANT-OMNI-5-0	2884923	1
<b>Antenna with omni-directional characteristics and mounting clamp</b> Antenna connection Gain Degree of protection Impedance Horizontal transmission angle Vertical transmission angle	∅ 48 to 95 mm N female connector 6 dBi IP55 50 Ω 360° 30°	RAD-ISM-2400-ANT-OMNI-6-0	2885919	1
<b>Panel antenna with omni-directional characteristics and mounting clamp</b> Antenna connection Gain Degree of protection Dimensions (W x H x D)	∅ 40 to 60 mm SMA 8 dBi IP55 101 x 80 x 20 mm	RAD-ISM-2400-ANT-PAN-8-0	2867610	1
<b>Antenna with omni-directional characteristics and protection against vandalism</b> Antenna connection Gain Degree of protection Impedance Connecting cable length	SMA connector 3 dBi IP55 50 Ω 1.5 m	RAD-ISM-2400-ANT-VAN-3-0-SMA	2885867	1
<b>Mounting support</b> for wall mounting of the OMNI-directional antenna with protection against vandalism		RAD-ANT-VAN-MKT	2885870	1
<b>Coaxial antenna cable</b> Connection Attenuation Impedance	1 m MCX / SMA 2 dBi 50 Ω	RAD-PIG-EF316-MCX-SMA	2867678	1
<b>Coaxial antenna cable</b> Connection Attenuation Impedance	0.3 m N female connector/ SMA 1.5 dBi 50 Ω	RAD-PIG-EF316-N-SMA	2867694	1
<b>Adapter N (female) &gt; N (female)</b>		RAD-ADP-N/F-N/F	2867843	1
<b>Adapter SMA (female) &gt; SMA (female)</b>		RAD-ADP-SMA/F-SMA/F	2884541	1
<b>Adapter RSMA (female) &gt; RSMA (female)</b>		RAD-ADP-RSMA/F-RSMA/F	2884538	1
<b>Surge voltage protection</b> - Total surge current (8/20) μs of 20 kA, insertion attenuation at 2.4 GHz to 2.5 GHz < 0,3 dB, N female connector/N female connector		CN-UB-280DC-BB	2818850	1
<b>Surge voltage protection</b> - Total surge current (8/20) μs of 20 kA, insertion attenuation at 2.4 GHz to 2.5 GHz < 0,3 dB, N male connector/N female connector		CN-UB-280DC-SB	2818148	1
<b>Weather-protection tape</b> - Self-vulcanizing for the protection of adapters, splitters, and cable connections, watertight		RAD-TAPE-SV-25-10	2885812	1

**Accessories**

Description	Order Designation	Order No.	Pcs./Pkt.
<b>Antenna cable</b>			
Antenna cable, 3 m, SMA (male) > SMA (male)	RAD-CAB-EF142-3M	2884512	1
Antenna cable, 5 m, SMA (male) > SMA (male)	RAD-CAB-EF142-5M	2884525	1
Antenna cable, 3 m, N (male) > N (male)	RAD-CAB-EF393-3M	2867649	1
Antenna cable, 5 m, N (male) > N (male)	RAD-CAB-EF393-5M	2867652	1
Antenna cable, 10 m, N (male) > N (male)	RAD-CAB-EF393-10M	2867665	1
Antenna cable, 15 m, N (male) > N (male)	RAD-CAB-EF393-15M	2885634	1
<b>Pigtail</b>			
Pigtail, 1 m, MCX (male) > SMA (male)	RAD-PIG-EF-316-MCX-SMA	2867678	1
Pigtail, 0.5 m, MCX (male) > N (male)	RAD-PIG-EF-316-MCX-N	2867681	1
Pigtail, 0.3 m, N (female) > SMA (male)	RAD-PIG-EF316-N-SMA	2867694	1
Pigtail, 0.5 m, N (female) > N (male)	RAD-PIG-EF316-N-N	2867704	1
Pigtail, 0.5 m, SMA (male) > SMA (male)	RAD-PIG-EF316-SMA-SMA	2885618	1
D-SUB cable as a serial connecting cable	VS-09-DSUB-20-LI-1,0	1656233	1
RS-232 cable, 9-pos. SUB-D female to 9-pos. SUB-D female connector	PSM-KA9SUB9/BB/0,5METER	2708520	1
RS-232 (V.24) null modem connector	PSM-AD-D9-NULMODEM	2708753	1

**Documentation**

Description	Type	Order No.	Pcs./Pkt.
User manual for the FL BLUETOOTH AP	UM EN FL BLUETOOTH AP	2888767	

**3 Technical data**

<b>General data</b>	
Function	Serial Bluetooth adapter
Housing dimensions (width x height x depth) in mm	80 x 25 x 65
Permissible operating temperature	-30°C to 65°C
Permissible storage temperature	-40°C to 85°C
Degree of protection	IP20, DIN 40050, IEC 60529
Class of protection	IEC 61140
Humidity	
Operation	5% to 90%, no condensation
Storage	10% to 95%, no condensation
Air pressure	
Operation	79.5 kPa to 108 kPa, 2000 m above sea level
Storage	70 kPa to 108 kPa, 3000 m above sea level
Mounting position	Any position on a flat mounting surface
Connection to protective earth ground	Not required
Weight	95 g, typical
<b>Supply voltage (US1/US2 redundant)</b>	
Connection	Via COMBICON; conductor cross section = 2.5 mm <sup>2</sup> , maximum
Nominal value	24 V DC (SELV)
Permissible voltage ranges	9 V DC to 30 V DC
Typical current consumption on US at 24 V DC	200 mA
Typical power consumption	5 W

## Interfaces

### Bluetooth interface

Version	Bluetooth according to IEEE 802.15.1; 2.4 GHz to 1 Mbps
Transmission power	16.9 dBm, maximum, can be automatically controlled or set manually
Receiver sensitivity	-85 dBm
Wireless modules that can be connected	1
Supported profiles	SPP
<b>Bluetooth antenna</b>	
Characteristic	Omni-directional antenna (can be replaced)
Gain	0 dBi
Connection	SMA
<b>Bluetooth functions</b>	
Function	Bridge, P2P
Configuration	Using web-based management, serial interface or AT commands via Bluetooth
Security	128-bit data encryption
<b>Serial interface</b>	
Version	D-SUB female connector, 9-pos., RS-232, RS-422 and RS-485 (2-wire)
Transmission speed	300 to 921600 baud, with CTS/RTS flow control or without flow control
Maximum serial cable length	3 m

## Mechanical tests

Shock test according to IEC 60068-2-27	Operation: 25g, 11 ms period, half-sine shock pulse Storage/transport: 50g, 11 ms period, half-sine shock pulse
Vibration resistance according to IEC 60068-2-6	Operation/storage/transport: 5g, 10 - 150 Hz, Criterion 3
Free fall according to IEC 60068-2-32	1 m

## Approvals

FCC/CFR 47 Part 15, ETS 300 328

## Conformance with EMC directives

Noise emission according to EN 55022	Class B
Radio interference field strengths according to EN 55022	Class A
Electrostatic discharge (ESD) according to EN 61000-4-2	Contact discharge: $\pm 4$ kV Air discharge: $\pm 8$ kV
Electromagnetic fields according to IEC 61000-4-3	10 V/m; Criterion A
Conducted interference according to IEC 61000-4-6	10 V <sub>RMS</sub> ; Criterion A
Fast transients (burst) according to IEC 61000-4-4	Data lines: 1 kV; Criterion B Power supply lines: 0.5 kV; Criterion B
Surge voltages according to IEC 61000-4-5	Data lines: $\pm 1$ kV asymmetrical; Criterion B Power supply lines: $\pm 0.5$ kV symmetrical/asymmetrical; Criterion B

## Differences between this version and previous versions

Version 00: First version



## 4 Installation of FL BT SPA



A minimum distance of 50 cm between modules must be observed when mounting the FL BT SPAs.



Make sure that the antenna is not directly located in front of a metal surface. This may deteriorate the wireless features of the antenna in the long term.

### 4.1 Mounting the FL BT SPA on a flat surface

Mount the FL BT SPA onto a level surface and tighten it by using two screws (e.g., 84-M3 X 25-8.8 cylinder head screws). For the required drill hole distances, please refer to Figure 1 on page 5.



If the FL BT SPA is assembled in a control cabinet, the antenna must be led outside. For a list of corresponding accessories, please refer to "Accessories" on page 2.

### Drill hole template and housing dimensions

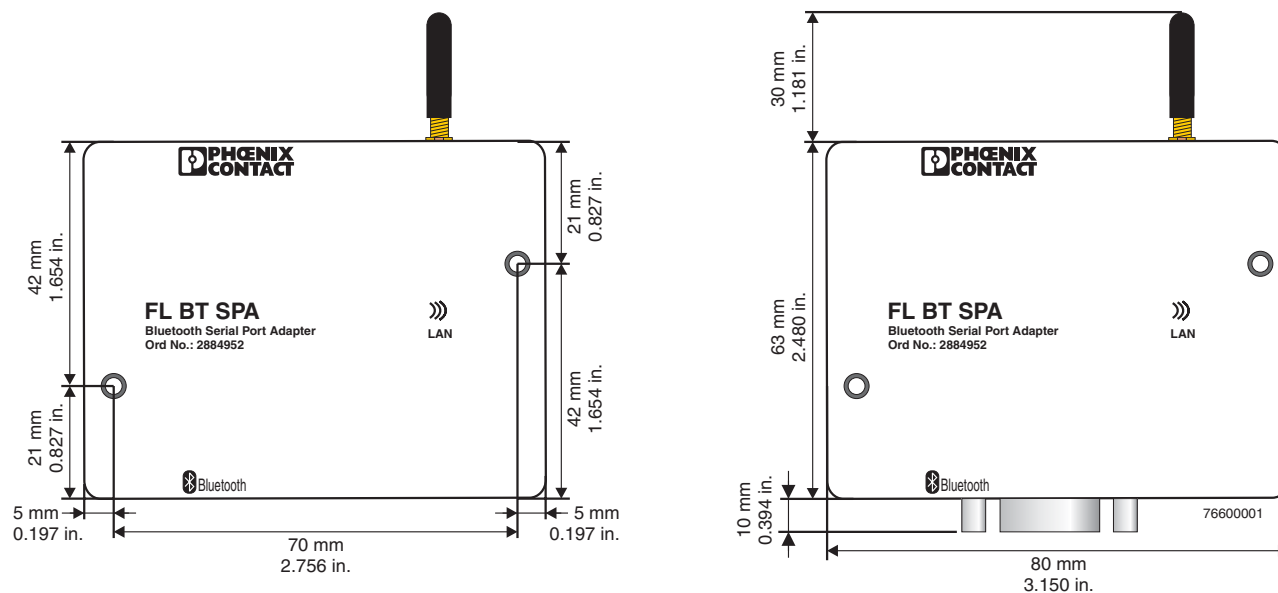
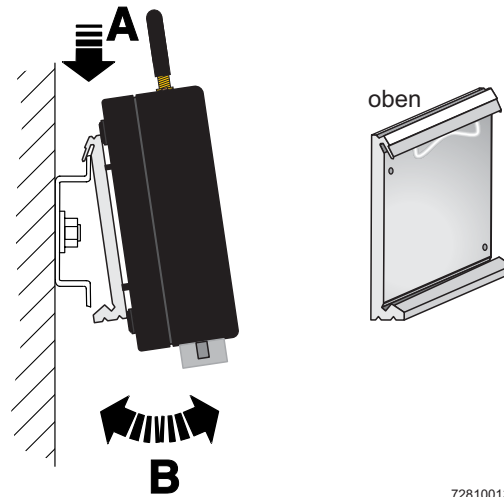

Figure 1 Housing dimensions and drill hole template for the FL BT SPA in millimeters (inches)

#### 4.2 DIN-rail mounting/removal of the FL BT SPA

Mount the DIN rail adapter (available as an accessory, see "Ordering data" on page 2) on the rear of the FL BT SPA. Make sure the adapter and FL BT SPA are positioned correctly (see diagram below). To mount the FL BT SPA place the upper holding keyway on the top edge of the DIN rail and push on the housing from the top (A). Then push the bottom edge of the housing towards the DIN rail until the adapter snaps onto the DIN rail (B).

To remove the device push on the housing from the top (A) and pull the bottom edge away from the DIN rail (B).



72810013

Figure 2 DIN rail mounting



A minimum distance of 50 cm between modules must be observed when mounting the FL BT SPAs.



Make sure that the antenna is not directly located in front of a metal surface. This may deteriorate the wireless features of the antenna in the long term.

## 5 FL BT SPA installation/interfaces

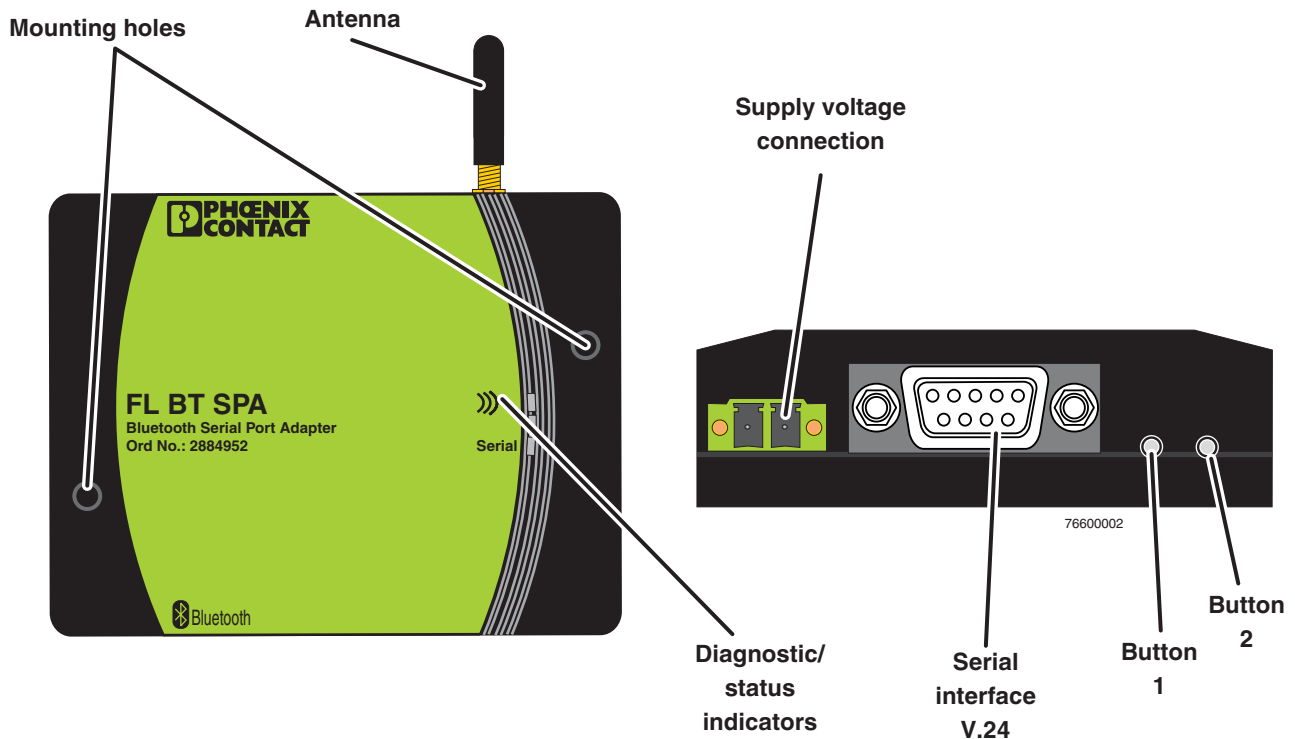

Figure 3 View and interfaces of the FL BT SPA

- Mounting holes  
Using these holes, you can install the FL BT SPA on a level surface using two screws (e.g., 84-M3 X 25-8.8 cylinder head screws) (for drill hole distance, see Figure 1 on page 5).
- Antenna  
The device is supplied with a 0 dB omni-directional antenna. You can exchange the supplied antenna for a different antenna in compliance with the national regulations.
- Supply voltage connection  
The supply voltage is connected using the 2-pos. COMBICON connector.
- Button 1 is used to reset the settings for the serial interface, pressing buttons 1 and 2 resets the device to the default settings.
- Status and diagnostic indicators  
The LEDs display the status of the serial and Bluetooth interfaces.



Please note that the depth of the two buttons in the housing is different.

- Serial interface - V.24  
V.24 (RS-232) interface in D-SUB format (9-pos.).



## 6 Connecting the 24 V DC supply voltage

The FL BT SPA is operated with a 24 V DC voltage. The FL BT SPA has an internal protection against polarity reversal.

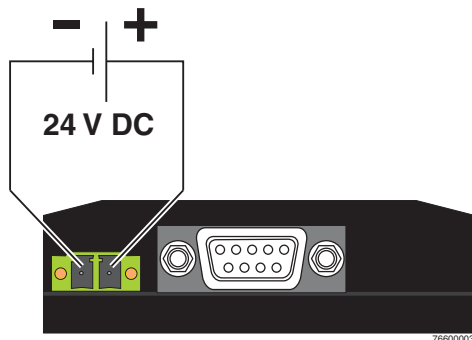

Figure 4 Supply of the FL BT SPA

## 7 Status and diagnostic indicators

There are three LEDs on the front of the device that display different states.

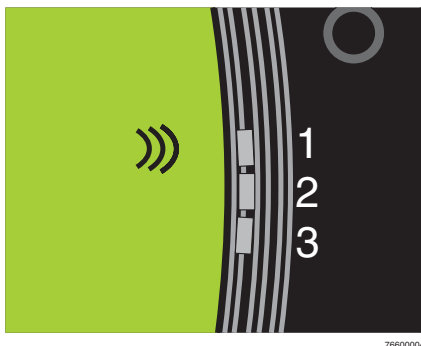

Figure 5 LEDs on the device front

Des.	Color	Status	Meaning
))) (LED 1)	Blue/ red/ green/ orange/ violet	ON (blue)	Further device connected with access point (blue)
		Flashing blue	Bluetooth data transmission
		Flashing red	Faulty data or data rate
		Green	Device in data mode, no connection at present
		Red	Configuration mode
		Violet	Bluetooth connection establishment
LED 2	No function		
LED 3	Yellow	ON	Transmission/reception of serial data
		OFF	No transmission/reception of serial data

## 8 V.24 (RS-232) interface



The maximum length of the serial cables is 3 m.

### 8.1 Assignment of the D-SUB female connector as RS-232 interface

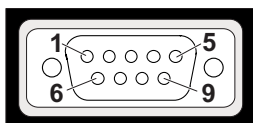

Frontseite  
Frontside  
Partie front.  
Lato front.  
Cara frontal

Figure 6 Assignment of the serial interface

#### Pin assignment of the serial interface with RS-232

- Pin 1: Not used
- Pin 2: RD (Receive Data), input
- Pin 3: TD (Transmit Data), output
- Pin 4: DTR (Data Terminal Ready), output
- Pin 5: GND
- Pin 6: DSR (Data Set Ready), input
- Pin 7: RTS (Request To Send), output
- Pin 8: CTS (Clear To Send), input
- Pin 9: Not used

#### Assignment of crossover cables (null-modem cable)

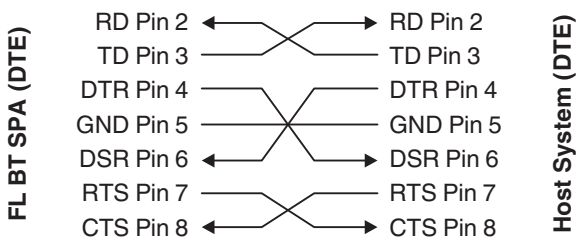

Figure 7 Assignment of a crossover cable

#### Assignment of 1:1 cables

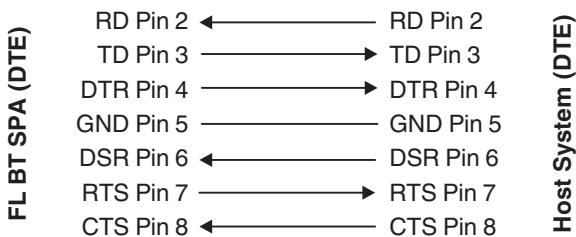
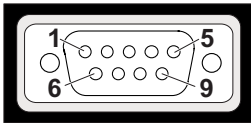

Figure 8 Assignment of 1:1 cables

## 8.2 Assignment of the D-SUB female connector as an RS-422 interface



For third-party manufacturers the definition of the R+/R- and T+/T- signals can differ.



Frontseite  
Frontside  
Partie front.  
Lato front.  
Cara frontal

### Pin assignment of the serial interface with RS-422

Pin 1: R- (Receiver), input  
Pin 2: T- (Transmitter), output  
Pin 3: Not used  
Pin 4: Not used  
Pin 5: Not used  
Pin 6: R+ (Receiver), input  
Pin 7: Not used  
Pin 8: T+ (Transmitter), output  
Pin 9: Not used

Figure 9 Assignment of the serial interface

## 8.3 Assignment of the D-SUB female connector as an RS-485 interface



For third-party manufacturers the definition of the R+/R- and T+/T- signals can differ.

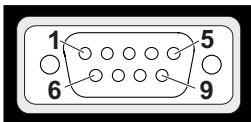

Frontseite  
Frontside  
Partie front.  
Lato front.  
Cara frontal

### Pin assignment of the serial interface with RS-485

Pin 1: R- (Receiver), input  
Pin 2: T- (Transmitter), output  
Pin 3: Not used  
Pin 4: Not used  
Pin 5: Not used  
Pin 6: R+ (Receiver), input  
Pin 7: Not used  
Pin 8: T+ (Transmitter), output  
Pin 9: Not used

Figure 10 Assignment of the serial interface



When the interface is used as a RS-485 interface the signals/pins T+ (pin 8) and R+ (pin 6) as well as T- (pin 2) and R- (pin 1) must be generated to generate the signals T+/R+ and T-/R-.

## 9 Configuration

### 9.1 Resetting the V.24 (RS-232) interface to default settings

At the bottom of the device there are two buttons next to the serial interface. Keep button 1 pressed during power-up to reset the device to its default settings.

### 9.2 Resetting the entire device to default settings

At the bottom of the device there are two buttons next to the serial interface. Keep button 1 and button 2 pressed during power-up to reset the device to its default settings.

### 9.3 Configuration using the web interface or AT commands

The FL BT SPA can be configured together with an FL BLUETOOTH AP via a serial port using its web interface or a special software. AT command can be used for configuration in both cases.



The software as well as a Quick Start Guide are available for download at [www.download.phoenixcontact.com](http://www.download.phoenixcontact.com).



For a list with AT commands that can be used, please refer to [www.download.phoenixcontact.com](http://www.download.phoenixcontact.com).

### 9.4 Configuration via the web interface of the FL BLUETOOTH AP

To configure the FL BT SPA, select the "SPA" profile on the "Connections" website in the web-based management (WBM) of the FL BLUETOOTH AP.



For further information on the configuration of the FL BLUETOOTH AP, please refer to the UM EN FL BLUETOOTH AP user manual, which can be downloaded at [www.download.phoenixcontact.com](http://www.download.phoenixcontact.com).

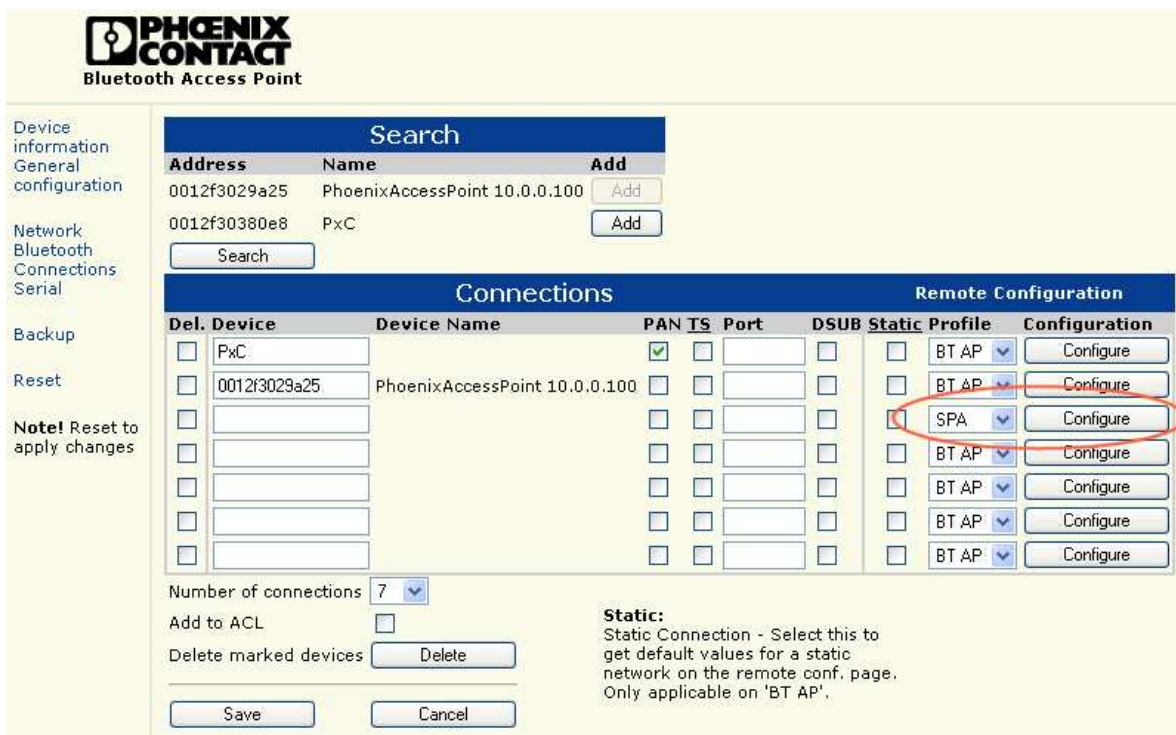

Figure 11 "Connections" website for the FL BLUETOOTH AP

After you have selected "SPA" under "Profile", simply click the "Configure" button to open the following website.

Figure 12 SPA configuration in the WBM of the FL BLUETOOTH AP

### 9.5 How to proceed during configuration

1. Click the "Enter AT mode" button. "OK" appears at the bottom part of the window.
2. Afterwards click the "Read" button. Then the device reads the data and fields such as "Baud Rate" or "Parity" are filled.
3. Now select the desired configuration.
4. Click the "Write" button to transmit the configuration to the device.

### 9.6 Configuration using the Bluetooth dongle



A Quick Start Guide can be downloaded at [www.download.phoenixcontact.com](http://www.download.phoenixcontact.com).

### 9.7 Configuration of the RS-232 interface using the software tool



A Quick Start Guide can be downloaded at [www.download.phoenixcontact.com](http://www.download.phoenixcontact.com).