



Chipsmall Limited consists of a professional team with an average of over 10 year of expertise in the distribution of electronic components. Based in Hongkong, we have already established firm and mutual-benefit business relationships with customers from,Europe,America and south Asia,supplying obsolete and hard-to-find components to meet their specific needs.

With the principle of “Quality Parts,Customers Priority,Honest Operation,and Considerate Service”,our business mainly focus on the distribution of electronic components. Line cards we deal with include Microchip,ALPS,ROHM,Xilinx,Pulse,ON,Everlight and Freescale. Main products comprise IC,Modules,Potentiometer,IC Socket,Relay,Connector.Our parts cover such applications as commercial,industrial, and automotives areas.

We are looking forward to setting up business relationship with you and hope to provide you with the best service and solution. Let us make a better world for our industry!



Contact us

Tel: +86-755-8981 8866 Fax: +86-755-8427 6832

Email & Skype: info@chipsmall.com Web: www.chipsmall.com

Address: A1208, Overseas Decoration Building, #122 Zhenhua RD., Futian, Shenzhen, China



EMD-SL-LL-230

Electronic monitoring relay for level monitoring of conductive liquids

INTERFACE

Data sheet
103073_en_04

© PHOENIX CONTACT - 09/2009



1 Description

Increasingly higher demands are being placed on safety and system availability – across all sectors. Processes are becoming more and more complex, not only in mechanical engineering and the chemical industry, but also in plant and automation technology. Demands on power engineering are also increasing constantly.

Error-free and therefore cost-effective operation can only be achieved through continuous monitoring of important network and system parameters. Electronic monitoring relays in the EMD series are available for a wide range of monitoring tasks to avoid the consequences of errors or to keep them within limits.

The operating states are indicated using colored LEDs, errors that may occur can be sent to a control system via a floating contact or can shut down a part of the system. Some device versions are equipped with startup and response delays in order to briefly tolerate measured values outside the set monitoring range.

Features

- Filling level monitoring
- Pump up (minimum monitoring)
- Pump down (maximum monitoring)
- Adjustable switch-on delay
- Adjustable release delay
- 230 V AC supply voltage
- Two PDTs



WARNING: Risk of electric shock

Never carry out work when voltage is present.



Make sure you always use the the latest documentation.
It can be downloaded at www.phoenixcontact.net/download.

2 Ordering data

Description	Type	Order No.	Pcs. / Pkt.
Electronic monitoring relay for level monitoring of conductive liquids	EMD-SL-LL-230	2885906	1

3 Technical data

Input data	
Input name	Measuring input
Description of the input	Conductive probe, type: SK1, SK2, SK3
Function	Pumping up (minimum monitoring), pumping down (maximum monitoring)
Recovery time	500 ms
Max. probe voltage	16 V AC
Max. probe current	7 mA
Length of probe cable	< 1000 m Set value < 50% (Capacity 100 nF/km) < 100 m Set value 100% (Capacity 100 nF/km)
Switching Threshold	0.25 kΩ ... 100 kΩ (4 mS ... 1 μS)
Output data	
Contact type	2 floating PDT contacts
Nominal insulation voltage	250 V AC (in acc. with IEC 60664-1)
Interrupting rating (ohmic load) max.	750 VA (3 A/250 V AC, module aligned, ≤ 5 mm spacing) 1250 VA (5 A/250 V AC, module not aligned, ≥ 5 mm spacing)
Output fuse	5 A (fast-blow)
Supply	
Supply voltage	230 V AC -15 % ... +15% AC
Range of supply voltages	
Frequency range	48 Hz ... 63 kHz
Nominal power consumption	2 VA (1.5 W)
General data	
Mains type	1-phase
Service life mechanical	Approx. 2×10^7 cycles
Service life, electrical	2×10^5 cycles at ohmic load, 1000 VA
Switching frequency	max. 60 (per minute at 100 VA ohmic load) max. 6 (per minute at 1000 VA ohmic load)
Operating mode	100% operating factor
Degree of protection	IP40 (housing) / IP20 (connection terminal blocks)
Pollution degree	2 (according to EN 50178)
Surge voltage category	III, basic insulation (as per EN 50178)
Rated insulation voltage	300 V (According to EN 50178)
Assembly	on TS 35 profile rail acc. to EN 60715
Mounting position	Any
Width	22.5 mm
Height	113 mm
Length	90 mm

General data (Continued)

Type of housing	Polyamide PA, self-extinguishing
Color	green
Weight	160 g

Connection data

Conductor cross section, solid	0.5 mm ² ... 2.5 mm ²
Conductor cross section, stranded	0.25 mm ² ... 2.5 mm ²
Stripping length	8 mm
Type of connection	Screw connection
Tightening torque	1 Nm

Ambient conditions

Ambient temperature (operation)	-25 °C ... 55 °C -25 °C ... 40 °C (corresponds to UL 508)
Ambient temperature (storage/transport)	-25 °C ... 70 °C
Permissible humidity (operation)	15 % ... 85 %
Climatic class	3K3 (in acc. with EN 60721)

Conformance / approvals

Conformity	CE compliant
UL, USA / Canada	UL/C-UL listed UL 508

Conformance with EMC directive 2004/108/EC

Immunity to interference according to	EN 61000-6-2
Emitted interference according to	EN 61000-6-3

Conformance with LV directive 2006/95/EC

Electronic equipm. for electrical power installations according to	EN 50178
--	----------

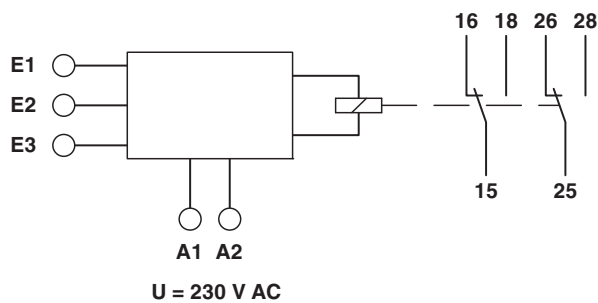
4 Block diagram**5 Safety notes****WARNING: Risk of electric shock**

Never carry out work when voltage is present.

6 Structure

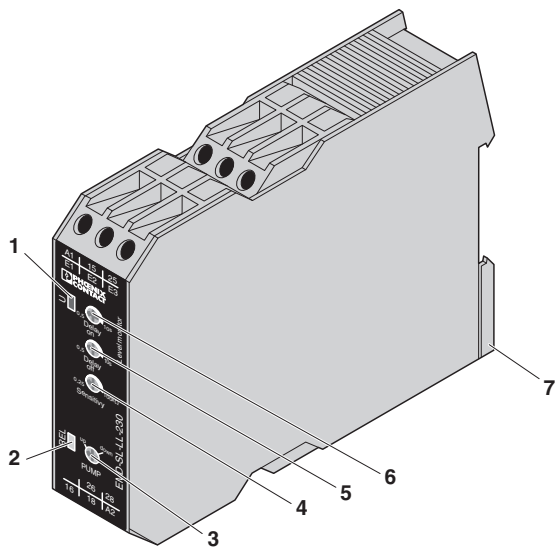

- 1 "U" LED: Supply voltage
- 2 "REL" LED: Output relay
- 3 "FUNCTION" rotary switch: Function selection
- 4 "SENSITIVITY" potentiometer: Sensitivity control
- 5 "DELAY OFF" potentiometer: Release delay
- 6 "DELAY ON" potentiometer: Switch-on delay
- 7 Universal snap-on foot for EN DIN rails

7 Installation



WARNING: Risk of electric shock

Never carry out work when voltage is present.

The module can be snapped onto all 35 mm DIN rails according to EN 60715.

8 Diagnostics

The LEDs indicate the following error states:

"U" LED (Green)

- LED ON: Supply voltage present

"REL" LED (Yellow)

- LED ON: Output relay has picked up
- LED OFF: Output relay has dropped out

9 Connection example

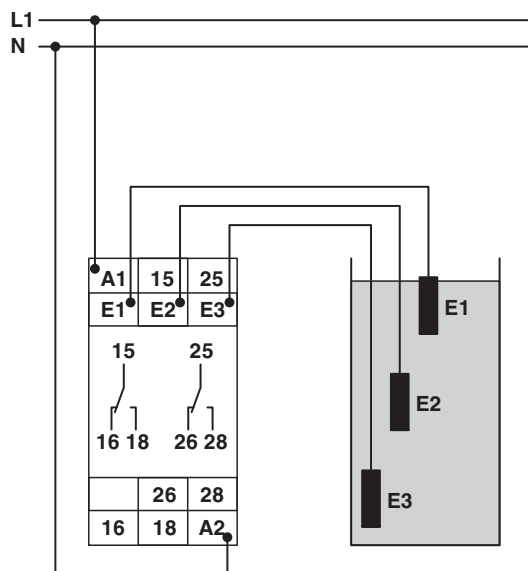

10 Function

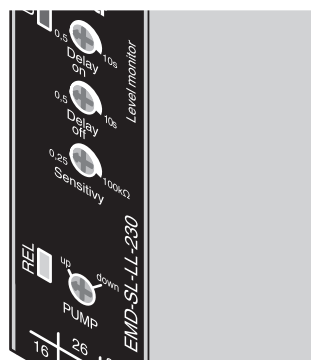

The "FUNCTION" rotary switch is used to set the desired function:

- PUMP UP = Pump up or minimum monitoring
- PUMP DOWN = Pump down or maximum monitoring

Setting the Monitoring Relay Prior to Startup

- Set the time delays ("DELAY ON" and "DELAY OFF" potentiometers) to 0.5 s, minimum.
- Set the rotary switch to the "PUMP DOWN" function.
- With probes submersed slowly turn the "SENSITIVITY" potentiometer clockwise from 0.25 k Ω towards 100 k Ω until the relay switches.
- Remove the probes from the liquid and check whether output relay "R" drops out. If the relay does not drop out when the probes are removed, slowly turn the "SENSITIVITY" potentiometer back counter-clockwise.
- Set the desired function ("PUMP UP" or "PUMP DOWN") and set the time delays to the desired values.

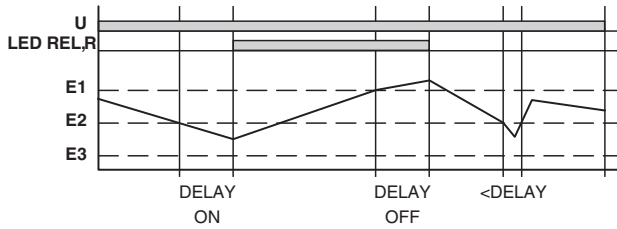

Pump Up (PUMP UP)

Connection of probe rods E1, E2, and E3. Instead of weight probe E3, the electrically conductive container can be connected as an alternative.

If the liquid level falls below minimum probe E2, the switch-on delay (DELAY ON) starts. After the delay time has elapsed, output relay "R" picks up again (yellow "REL" LED is ON).

If the liquid level rises above maximum probe E1, the release delay (DELAY OFF) starts. After the delay time has elapsed, output relay "R" drops out again (yellow "REL" LED is OFF).

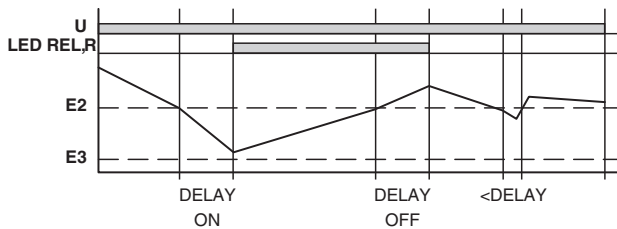

Minimum Monitoring (PUMP UP)

Connection of probe rods E2 and E3 (bridge E1-E3). Instead of weight probe E3, the electrically conductive container can be connected as an alternative.

If the liquid level falls below probe E2, the switch-on delay (DELAY ON) starts. After the delay time has elapsed, output relay "R" picks up again (yellow "REL" LED is ON).

If the liquid level rises above probe E2, the release delay (DELAY OFF) starts. After the delay time has elapsed, output relay "R" drops out again (yellow "REL" LED is OFF).

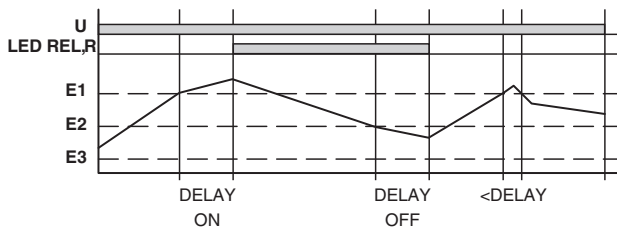

Pump Down (PUMP DOWN)

Connection of probe rods E1, E2, and E3. Probe rod E3 does not have to be connected if the container wall is made of metal.

If the liquid level rises above maximum probe E1, the switch-on delay (DELAY ON) starts. After the delay time has elapsed, output relay "R" picks up again (yellow "REL" LED is ON).

If the liquid level falls below minimum probe E2, the release delay (DELAY OFF) starts. After the delay time has elapsed, output relay "R" drops out again (yellow "REL" LED is OFF).

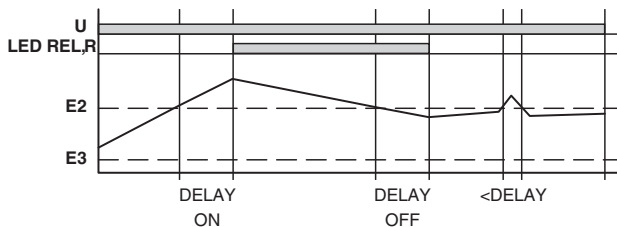

Maximum Monitoring (PUMP DOWN)

Connection of probe rods E2 and E3 (bridge E1-E3). Instead of weight probe E3, the electrically conductive container can be connected as an alternative.

If the liquid level rises above probe E2, the switch-on delay (DELAY ON) starts. After the delay time has elapsed, output relay "R" picks up again (yellow "REL" LED is ON).

If the liquid level falls below probe E2, the release delay (DELAY OFF) starts. After the delay time has elapsed, output relay "R" drops out again (yellow "REL" LED is OFF).